

Volvo Construction Equipment
Building Tomorrow



ROTATING PIPELAYER KIT

For 14-15 t Volvo Crawler Excavators







Maximum return for your investment

Maximize the productivity and profitability of your excavator with the unique rotating pipelayer kit.

This Volvo-patented solution converts conventional Volvo 14-ton crawler excavator – the EC140DLM – into a dedicated lifting/pipelayer specialist.

With similar capabilities as a side boom pipelayer, but far greater flexibility – an excavator can be switched to pipelayer in approximately 1 hour.

Two machines in one

Get the highest possible utilization from your excavator with the rotating pipelaying kit. It's never been easier to switch from excavator to pipelayer – and back again.

The most compact solution

Unlike a standard side boom pipelayer this Volvo-patented solution with rotating superstructure has no side boom, so can work in tight areas without positioning issues, especially useful when pipelaying in urban areas.



Speedy switch

Turn your conventional excavator into a pipelayer in approximately an hour, even faster with experience.

Easy transportation

Just load and go – no crane or extra people required.

Lift capacity

Safely handle pipes up to 508 mm, with a rated load capacity of 3.3 t.

Safer load management

Volvo's unique Load Moment Indicator ensures safe operation up to a 10° slope. The system gives real-time operator assistance – with alarms, lights & exterior warnings lamps, including the standard anti-two-block system.



Best-in-class for comfort

Operator comfort lies at the heart of Volvo designs and this solution is no exception. The operator always faces the load ahead, helping reduce fatigue. And with a closed, quiet and climate-controlled cab, safety and comfort are enhanced.

Operator friendly

One of the many advantages of having an excavator-based pipelayer is that it's more familiar to most operators than a side boom pipelayer. This makes recruitment and training easier and less expensive.

Lower maintenance costs

With almost all components in common with a standard 14-ton excavator, the excavator based pipelayer makes it easier to find parts and lowers maintenance costs.



Specifications

The kit you get

The rotating pipelayer kit is mounted on the excavator's boom. It consists of the pipelayer boom and all supporting components.

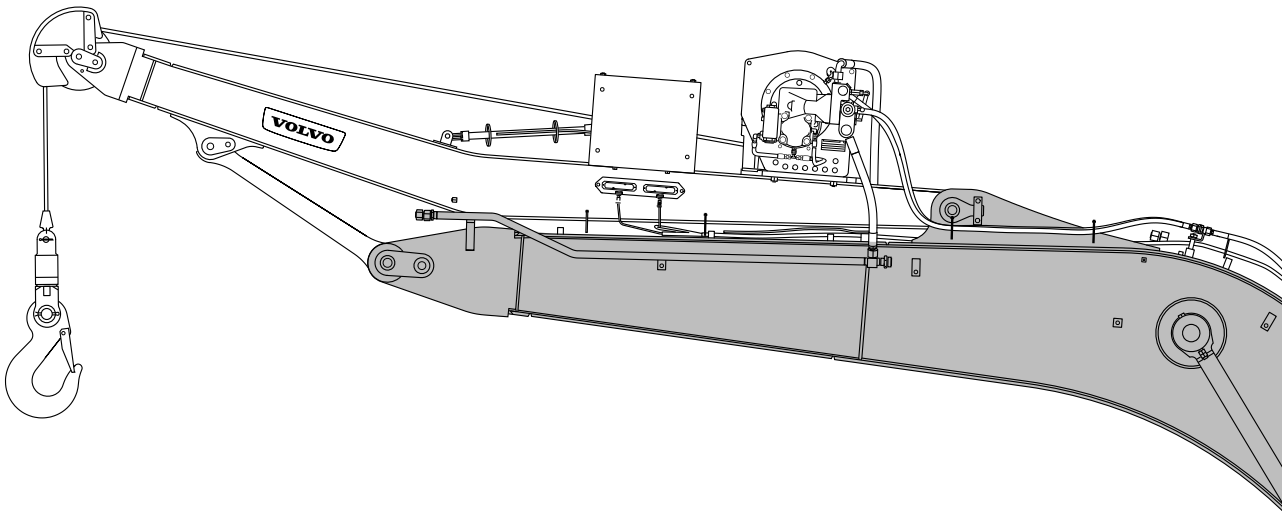

Machine configuration

The minimum machine configuration for using the rotating pipelayer kit is as follows:

- EC140DLM base machine
- 600 mm triple grouser shoe or 700 mm/800 mm/900 mm shoes
- General Purpose boom, 4.6 m Normal Bushing
- 1 pump double acting piping or 2 pump double acting piping
- Hose rupture protection boom cylinder
- 2 450 kg counterweight
- Oil drain line base machine
- FOG cabin mounted

Working ranges

EC140DLM

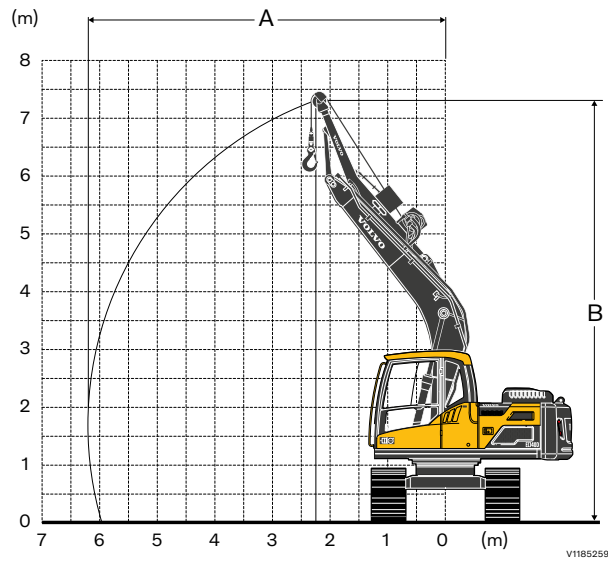

Boom + Rotating pipelayer kit = 5.98 m
 A Maximum working reach: 6205 mm
 B Maximum working height: 7317 mm

Lifting capacities

EC140DLM

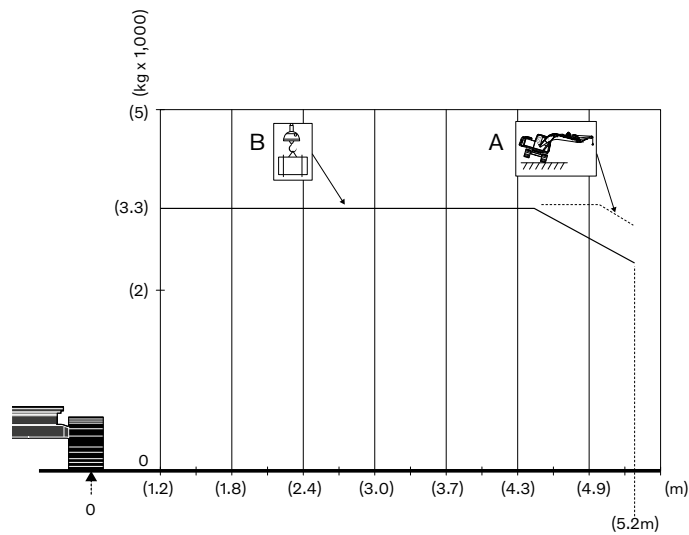

A Maximum tipping capacity
 B Rated capacity

Not all products are available in all markets. Under our policy of continuous improvement, we reserve the right to change specifications and design without prior notice. The illustrations do not necessarily show the standard version of the machine.

VOLVO

Volvo Construction Equipment

volvoce.com