



Volvo Construction Equipment

L45H, L50H

Volvo Wheel Loaders 8.6-9.9 t 99-118 hp



A passion for performance

At Volvo Construction Equipment, we're not just coming along for the ride. Developing products and services that raise productivity – we are confident we can lower costs and increase profits for industry experts. Part of the Volvo Group, we are passionate about innovative solutions to help you work smarter – not harder.

Helping you to do more

Doing more with less is a trademark of Volvo Construction Equipment. High productivity has long been married to low energy consumption, ease of use and durability. When it comes to lowering life-cycle costs, Volvo is in a class of its own.

Designed to fit your needs

There is a lot riding on creating solutions that are suited to the particular needs of different industry applications. Innovation often involves high technology – but it doesn't always have to. Some of our best ideas have been simple, based on a clear and deep understanding of our customers' working lives.



You learn a lot in 180 years

Over the years, Volvo has advanced solutions that have revolutionized the use of construction equipment. No other name speaks Safety louder than Volvo. Protecting operators, those around them and minimizing our environmental impact are traditional values that continue to shape our product design philosophy.

We're on your side

We back the Volvo brand with the best people. Volvo is truly a global enterprise, one that is on standby to support customers quickly and efficiently – wherever they are.

We have a passion for performance.



Volvo Trucks



Renault Trucks



Mack Trucks



UD Trucks



Volvo Buses



Volvo Construction Equipment



Volvo Penta



Volvo Financial Services

The Best All-rounder

More than 60 years in the making, Volvo is proud to introduce the next generation L45H and L50H wheel loaders. These versatile machines are a powerful asset on every jobsite in every application.

Intelligent hydraulic system

Volvo's load-sensing hydraulic system drives power to the hydraulic functions according to demand, giving you fast response for shorter cycle times while lowering fuel consumption. Ensuring superior load control together with a careful balance between lifting and tractive forces, this powerful system provides highly effective bucket penetration for all types of digging conditions.



Boom suspension system (BSS)

The optional Boom Suspension System boosts productivity by up to 20% by absorbing shock and reducing the bouncing and bucket spillage that occurs when operating on rough ground. This enables faster and more comfortable work cycles and increases machine life.



Auxiliary hydraulics

The machines can be factory-fitted with extra hydraulic lines to operate and run a variety of hydraulically driven attachments.



Comfort Drive Control (CDC)

The CDC gives the operator the choice to operate the machine by lever control. This improves operator comfort and ensures better productivity over long working hours. It also reduces operator fatigue, which may occur during repetitive work.





TP LINKAGE

Volvo's unique Torque Parallel (TP) linkage delivers high breakout torque and excellent parallel movement throughout the entire lifting range.



ATTACHMENT RANGE

Volvo's wide range of durable attachments have been purpose-built to work in perfect harmony with Volvo machines. The attachments are designed as an integrated part of the wheel loader for which they're intended – with functions and properties perfectly matched to parameters including link-arm geometry and breakout, rim pull and lifting force.

Get attached

Get flexible on site with original Volvo attachments. Volvo's wide range of durable attachments is designed as an integrated part of the wheel loader for which they're intended. Their functions and properties perfectly match link-arm geometry to optimise breakout, rim pull and lifting force.

Volvo Attachment Bracket TPZ (VAB-TPZ)

The Volvo VAB-TPZ attachment bracket allows you to easily swap attachments with a TPZ interface. The sleek bracket design brings the attachment closer to the machine for better payload.



Standard Volvo Attachment Bracket (VAB-STD)

Volvo's standard hydraulic attachment bracket VAB-STD, also known as TPV, is internationally ISO standardized and allows a quick and safe interchange of attachments for more flexibility on site. The strong, open bracket design enables the operator to clearly see attachment points from the cab.



Tackle every terrain

Whether working on rough terrain or smooth concrete, Volvo's L45H and L50H wheel loaders give you top performance. Quality is built into every inch of the machines, from the differential lock that transfers 100% power to all wheels, to the hydrostatic transmission which offers smooth speed increase. Conquer your site with Volvo.

Inch-brake pedal

The inch-brake pedal gives best possible machine control. Applying light pressure on the pedal reduces speed using the transmission, and further pressure engages the wet disc brakes to hold the loader.



Axles and differential locks

While the heavy-duty planetary axles ensure long life in the toughest conditions, the front and rear 100% differential locks feature a dog clutch locking capability and a no slip, no wear design to improve grip and ensure maximum traction on all terrain.



Hydrostatic drive

The fuel efficient hydrostatic transmission matches power to requirement. It provides excellent control in delicate work and full power for more demanding jobs.



Stage IV Engine

Volvo's Stage IV engine complies with the latest emissions legislation and delivers high torque at low engine rpm. The engine features an Exhaust Gas Recirculation (EGR) in combination with an integrated Diesel Particulate Filter (DPF) and Selective Catalytic Reduction (SCR) system. DPF regeneration is maintained without any loss of machine performance or interference with the operation of the machine.



Reversible cooling fan

The hydraulically-driven electronically controlled cooling fan regulates the temperature of vital components. It automatically activates only when it's needed – reducing fuel consumption and noise. The reversible functionality – which blows air in the opposite direction – allows for self-cleaning of the cooling units.

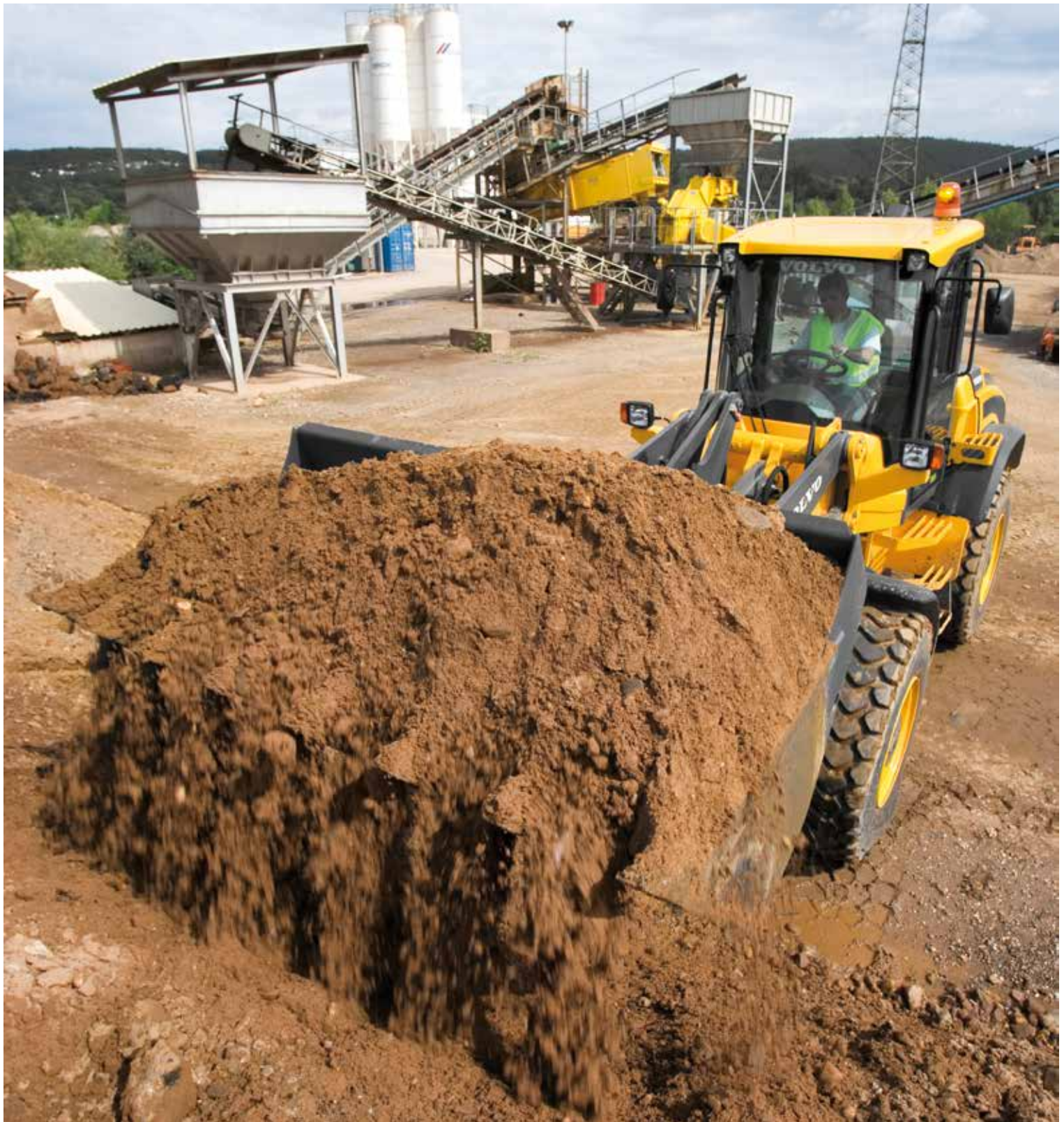

OPTIMISED DRIVELINE

The engine, transmission and axles are all designed to work in perfect harmony with the hydraulics and steering for superb performance, durability and reliability.

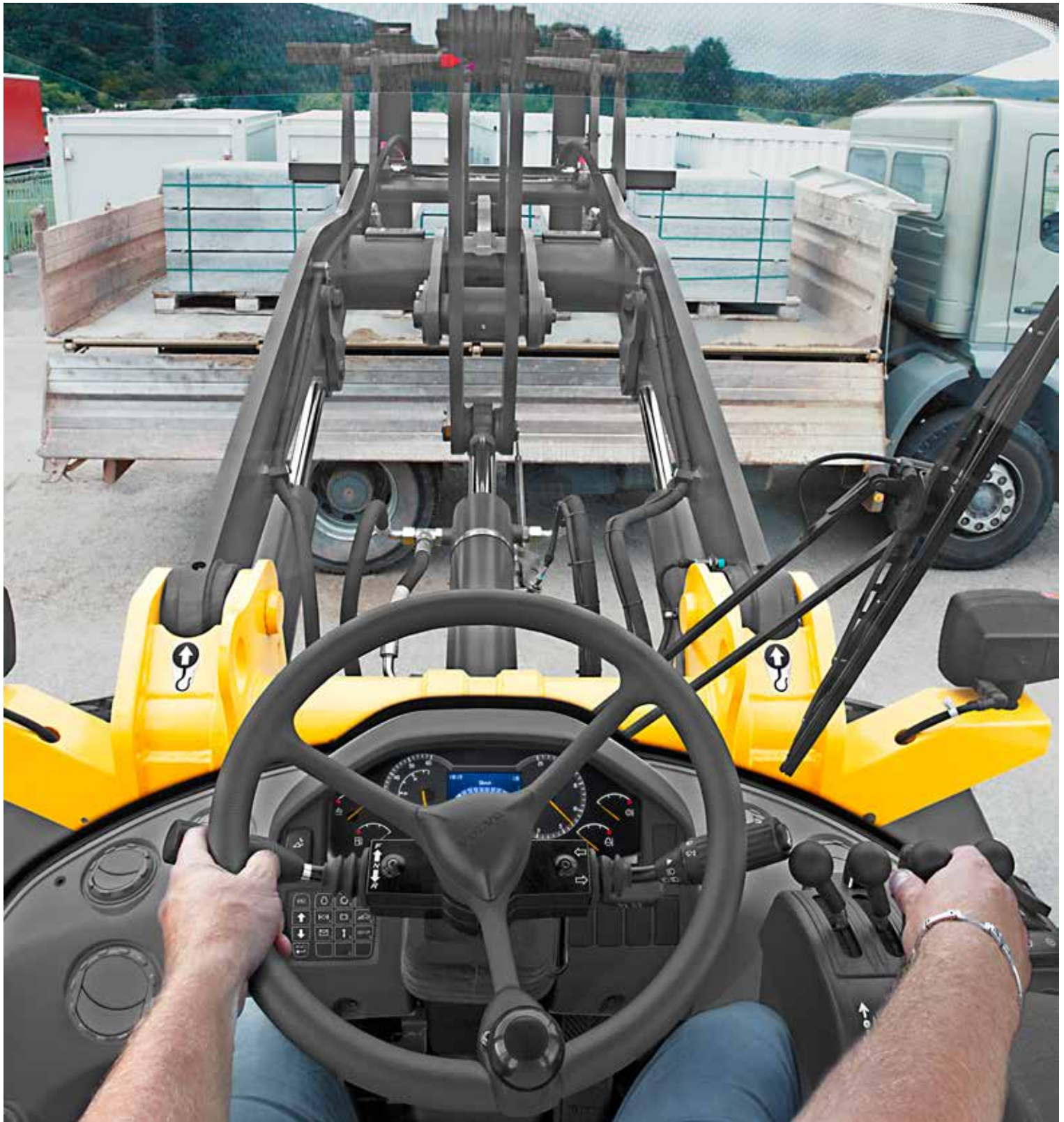

CAB

The certified ROPS/FOPS cab features ergonomically placed controls, a superior climate control system, all-around visibility and low internal noise levels.

Your control center

Step into Volvo's industry-leading cab; your customized control room. Create your perfect working environment by adjusting the seat and steering wheel to fit your needs, then select the easy-to-reach controls. Excellent all-round visibility gives you the best view of your efficient work.

Fitted to your needs

Operate with a joystick or multi-lever hydraulic pilot control, depending on your preference. Both provide steady and precise load control.



Human Machine Interface

Increase uptime with Volvo's state-of-the-art Contronic system, which continuously monitors machine performance and communicates diagnostics to the operator via a screen in the cab.



Climate control

Operators remain focused and efficient thanks to Volvo's climate control system. Select optional Automatic Heat Control (AHC) or Air Conditioning (AC) for the perfect cab temperature.



Air filter

The cab air intake is located high on the machine, where air is cleanest. The easy-to-replace pre-filter separates coarser dust and particles before the air passes through the main filter and finally enters the cab, giving the operator the freshest air.



Cab access

Large, anti-slip steps and handrails ensure easy cab entry and exit.



Quiet and steady

Moulded cab roof and walls keep noise and rubber mounts keep vibration to a minimum, reducing operator fatigue.



Small size: big talent

Load-sensing hydraulics

Load-sensing hydraulics deliver power to hydraulic functions only when it's needed, lowering fuel consumption.

OPTIMISED DRIVELINE

The engine, transmission and axles are all designed to work in perfect harmony with the hydraulics and steering for superb performance and reliability.

Analysis software

Maintain machine uptime by using Volvo's diagnostic computer-based analysis software: MATRIS and VCADS Pro.

TP LINKAGE

Volvo's unique Torque Parallel linkage combines Z-Bar and Parallel linkage in one for high breakout torque and parallel movement through the entire lifting range.



AdBlue®

Volvo offers a total AdBlue solution that is quality assured, cost efficient and easily accessible. Contact your Volvo dealer for more information. ® = registered trademark of the Verband der Automobilindustrie e.V. (VDA)

ATTACHMENT RANGE

Volvo's wide range of high quality attachments are perfectly matched to the machine's linkage, hydraulics and driveline to increase productivity.



BALANCED & COMPACT DESIGN

Volvo's L45H and L50H wheel loaders give you top performance whether working on rough-terrain or smooth concrete.

Steering

Load-sensing hydrostatic steering system supplied from variable displacement pump. Excellent steering performance is maintained even at low engine speed. At the same time fuel consumption is reduced.

CAB

The certified ROPS/FOPS cab features ergonomically placed controls, a superior control system, all-around visibility and low internal noise levels.

SERVICE ACCESS & MAINTENANCE

The service friendly design keeps your routine maintenance quick and efficient with a full access to all main service and maintenance points.

Complete Solutions

Volvo provides the right solutions throughout the entire life cycle of your machine to lower total cost of ownership.

Differential lock front and rear

Select the differential lock to transfer 100% power to all wheels and reduce tire slippage for maximum traction on soft and slippery ground.

Solid, strong and stable

Volvo's L45H and L50H are compact and well balanced machines whose solid design gives you the strongest performance in the tightest jobsites. Quality is built into every inch of the machines.

Stability where you need it

A long wheel base, low center of gravity and good weight distribution gives the machine superior stability on rough and uneven terrain.



Transversal engine mounting

The Volvo-compliant L45H-L50H engine is assembled transversally – set back from the center of gravity, providing important advantages such as optimal weight distribution on the machine for enhanced driving stability. The powerful and fuel efficient Stage IV engine also provides high torque at low engine speeds for unrivalled performance combined with low fuel consumption. Furthermore, the transversal setup makes all service points and hydraulic pumps easily accessible on one side of the engine.



Strongest center hinge

The center hinge is designed to withstand considerable horizontal and vertical stress. The upper spherical plain bearing and lower fixed plain bearing are widely spaced to spread forces over a greater area for a long bearing life.



Counterweight design

The sloped design of the counterweight ensures the machine can achieve very high departure angles, while its compact shape improves manoeuvrability in confined spaces.



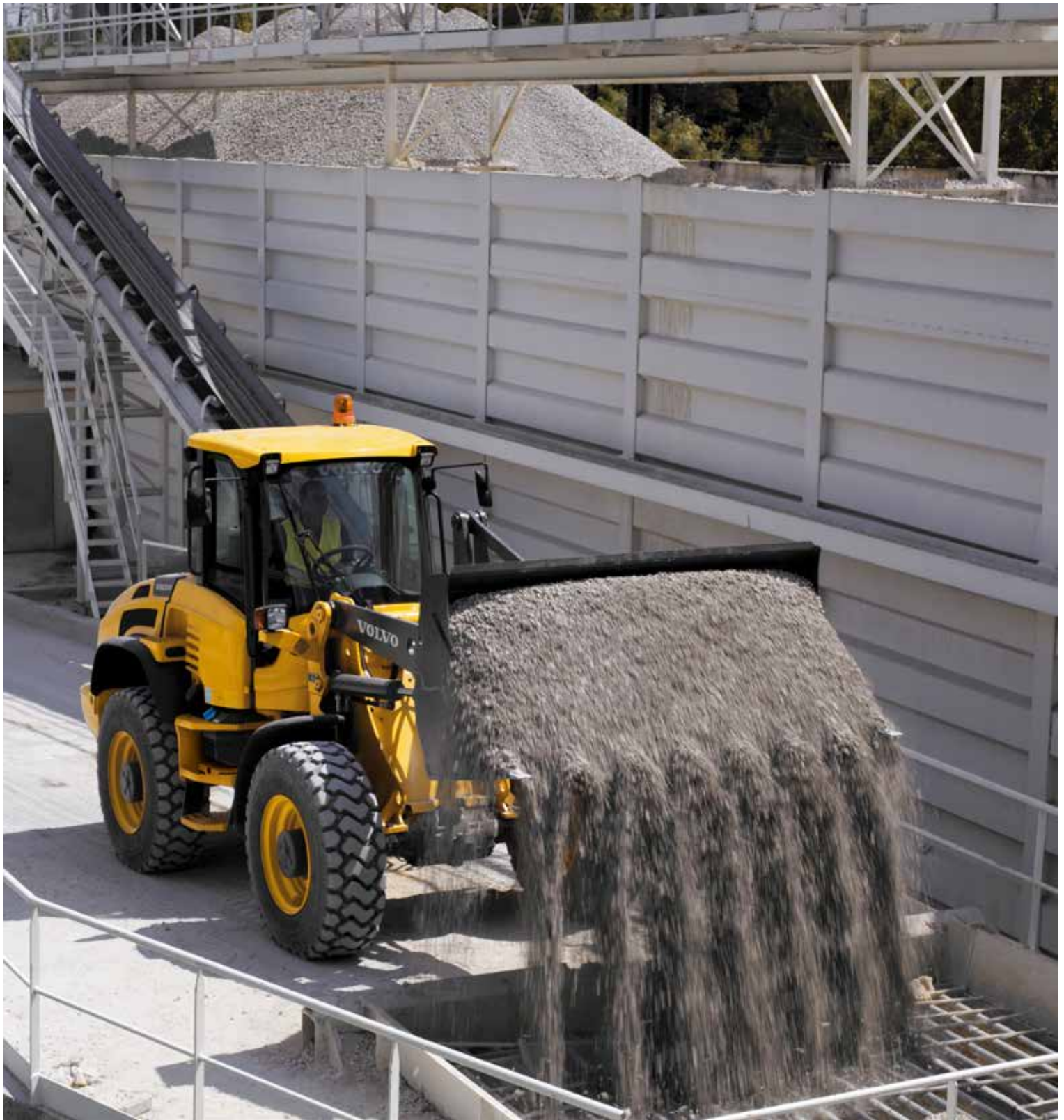

BALANCED & COMPACT DESIGN

Volvo's L45H and L50H wheel loaders give you top performance whether working on rough-terrain or smooth concrete. Conquer your site with Volvo.

Adding value to your business

Being a Volvo customer means having a complete set of services at your fingertips. Volvo can offer you a long-term partnership, protect your revenue and provide a full range of customer solutions using high quality parts, delivered by passionate people. Volvo is committed to increasing the positive return on your investment and maximising uptime.

Complete Solutions

Volvo has the right solution for you. So why not let us provide all your needs throughout the whole life cycle of your machine? By listening to your requirements, we can reduce your total cost of ownership and increase your revenue.



Genuine Volvo Parts

Our attention to detail is what makes us stand out. This proven concept acts as a solid investment in your machine's future. Parts are extensively tested and approved because every part is vital for uptime and performance. Only by using Genuine Volvo Parts, can you be sure that your machine retains the renowned Volvo quality.

Service Network

In order to respond to your needs faster, a Volvo expert is on their way to your job site from one of our Volvo facilities. With our extensive infrastructure of technicians, workshops and dealers, Volvo has a comprehensive network to fully support you using local knowledge and global experience.





CUSTOMER SUPPORT AGREEMENTS

The range of Customer Support Agreements offer preventive maintenance, total repairs and a number of uptime services. Volvo uses the latest technology to monitor machine operation and status, giving you advice to increase your profitability. By having a Customer Support Agreement you are in control of your service costs.



SERVICE ACCESS & MAINTENANCE

The service friendly design keeps your routine maintenance quick and efficient with a full access to the engine compartment and engine maintenance points for quick and easy service checks. Service points (radiator, battery, oil, air and hydraulic filters) and quick drains are ground accessible under the engine hood, for quick completion of maintenance checks so you can spend more time working.

Compact your service time

Volvo's L45H and L50H are compact and well balanced machines whose solid design gives you the strongest performance in the tightest jobsites. Quality is built into every inch of the machines.

Maintenance-free rear axle oscillation

The oscillating rear axle is supported on maintenance-free cradles. Its bearings and bushings are lubricated-for-life and protected by well proven seals, saving you hours of maintenance time and increasing uptime.



Analysis software

Maximize machine uptime with Volvo's diagnostic analysis software. MATRIS analyses the machine's operational data and VCADS Pro can adjust machine function accordingly.



Engine air filter

The dual element air filter is located in the engine compartment for full protection of the engine.



Grouped grease points

Grease points are grouped together on the loader arm as well as on the centre hinge for easy and quick maintenance.



Volvo L45H, L50H in detail

Engine

Volvo Tier 4f / Stage IV compliant, 4 liter, 4-cylinder in-line turbocharged diesel engine; featuring common rail fuel injection system and externally cooled exhaust gas recirculation (EGR). Exhaust aftertreatment system includes a diesel oxidation catalyst (DOC), a diesel particulate filter (DPF) and a selective catalytic reduction (SCR). Cooling pack includes side by side arranged radiators for engine coolant, hydraulic oil and charge air cooler.

		L45H	L50H
Engine	Volvo	D4J	D4J
Max power at	r/min	1 800 - 2 200	1 800 - 2 200
SAE J1995 gross	kW	75	87
	hp	102	118
SAE J1349, ISO 9249 net	kW	73	85
	hp	99.3	116
Max. torque at	r/min	1 450	1 450
SAE J1995 gross	Nm	425	490
SAE J1349, ISO 9249 net	Nm	416	466
Economic working range	r/min	1 200 - 1 800	1 200 - 1 800
Displacement	l	4	4

Drivetrain

Hydrostatic transmission allows for of speed range change without any tractive power interruption. Maximum tractive power is available in all speed ranges, regardless of the driving direction. Automatic power regulation prevents engine stalling in case of additional power demand from the working hydraulics or the auxiliaries, and protects from overheating in case of overload. Fully floating axle shafts with planetary hub reductions and steel casted axle housing. Fixed front axle and oscillating rear axle, both self-lubricated. 100% differential lock on both axles.

		L45H	L50H
Angle of oscillation	± °	12	12
Oscillation at wheel, max.	mm	360	360
Track	mm	1 730	1 730
Travel speed, forward/reverse			
Low-speed version			
1st gear	km/h	0 - 6	0 - 6
2nd gear	km/h	0 - 20	0 - 20
High-speed version			
1st gear	km/h	0 - 6	0 - 6
2nd gear	km/h	0 - 30	0 - 30

Hydraulic system

Closed center load sensing hydraulic system with pilot operated control valves.

System supply:

A variable displacement piston pump provides flow to the working hydraulic and steering system. The steering function has always priority.

A gear pump provides flow to the braking system and the cooling fan.

System control:

Double-acting 3-spools main control valve (4-spools valve as option).

The lift function has four positions: lift, hold (neutral), lower and float position.

An optional automatic boom kick-out can be switched on and off and is adjustable to any position between maximum reach and full lifting height.

The tilt function has three positions: rollback, hold (neutral) and dump.

The standard bucket positioner system allows to easily adjust the tilt angle to a predefined position.

A third and fourth hydraulic functions are available as options to power hydraulic implements (Volvo hydraulic Attachment Bracket, Hi-Tip bucket, angle sweeper etc...)

Filtration:

Full-flow filtration through 10 micron (absolute) filter cartridge in a combined suction-return-filter.

Cooling:

Thermostatically controlled oil flow to oil cooler (fast warm-up, optimized cooling).

		L45H	L50H
Working pressure max	MPa	26	26
Flow	l/min	132	158
at engine speed	r/min	2 200	2 200
Pilot working pressure	MPa	2.5	2.5

Linkage

Double acting cylinder for all functions

		L45H	L50H
Linkage system	Torque parallel (TP)	Torque parallel (TP)	Torque parallel (TP)
Lift cylinders		2	2
Tilt cylinders		1	1
Lift time (loaded)	s	4.8	4.7
Lowering time (empty)	s	3.2	3.9
Dump time	s	1.5	1.2

Steering System

Load sensing hydrostatic articulated steering with double acting cylinders.

System supply:

The steering system has priority feed from the load-sensing axial piston pump with variable displacement.

Steering cylinders:

Two double-acting cylinders. Elastic end-stops.

		L45H	L50H
Steering cylinders		2	2
Working pressure	MPa	17.5	17.5
Maximum flow	l/min	70	70
Max articulation	± °	40	40

Brake system

The brake system complies with ISO 3450 requirements.

Single circuit service brake featuring hydraulically operated wet disk brakes on rear axle.

An Inching-brake pedal provides hydrostatic wearless braking in the first stage for precise approach; if applied further the service brakes takes over for final braking and machine immobilization.

Parking brake: Mechanically operated dry disc brake located on the input shaft of the front axle.

Electrical system

Contronic electrical system with central warning light and buzzer, providing clear and easy to read information to the operator.

LCD display with main and sub information field, adjustable to various languages.

Display information in three categories:

- Information on continuous operating data,
- Check requests (based on vehicle and error messages)
- Warning (with alarm texts).

Additional audible warning by a buzzer.

Indicator and activation lights for various control and monitoring functions.

Gauges for Adblue® level, fuel tank level, speedometer, engine speed, coolant temperature, transmission/hydraulic oil temperature.

A keypad allows easy navigation on the central instrument display.

Direct access buttons for Engine, Transmission, Hydraulics, Axles & Brakes, Electrical system, Vehicle information, Vehicle messages, Service, Settings and Cycle information.

		L45H	L50H
Voltage	V	24	24
Batteries	V	2x12	2x12
Battery capacity	Ah	2x100	2x100
Cold cranking capacity, approx	A	830	830
Alternator rating	W/A	3080 / 110	3080 / 110
Starter motor output	kW	5.5	5.5

Cab

The cab is tested and approved according to ROPS (ISO 3471, SAE J1040) and FOPS (ISO 3449).

The cab is compliant with ISO 6055 requirements regarding Operator overhead protection - Industrial trucks and SAE J386 regarding Operator Restraint System.

The operator's seat features an adjustable suspension and a retractable seatbelt.

Fresh air is filtered through two large elements prior entering, ensuring extremely clean air distribution in the cab.

11 air flow settings or an automatic mode provides efficient ventilation.

Air vents are available to all windows enabling fast de-misting and defrosting.

The contronic monitoring system provides all important information in a central position and all machine controls are located in the operator's field of vision.

Sound Level

		L45H	L50H
Sound level in cab according to ISO 6396			
LpA	dB(A)	70	70
LpA (as option)	dB(A)	68	68
External sound level according to ISO 6395			
LwA	dB(A)	102	102

Service Refill



		L45H	L50H
Fuel tank	l	150	150
DEF/AdBlue® tank	l	20	20
Engine oil	l	14	14
Engine coolant	l	20	20
Hydraulic tank	l	95	95
Transmission oil	l	1.2	1.2
Front axle oil	l	17.5	17.5
Rear axle oil	l	17.5	17.5



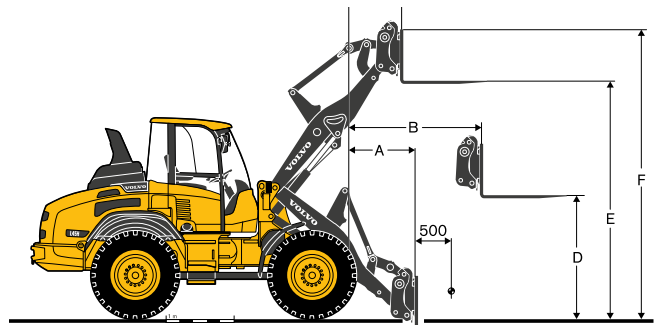
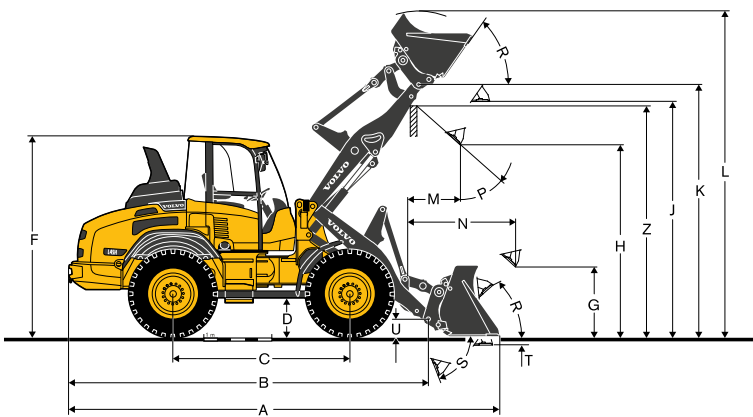
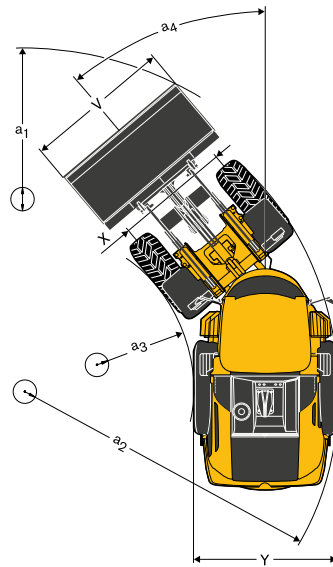

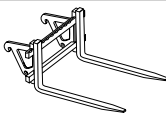
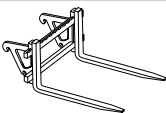
Specifications L45H

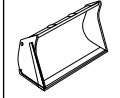
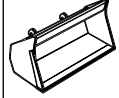
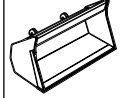
		With TP-linkage, TPV attachment bracket and 15.5-25 tires	With TP-linkage, TPZ attachment bracket and 15.5-25 tires
B	mm	5 320	5 325
C	mm	2 650	2 650
D	mm	395	395
F	mm	2 950	2 950
G	mm	1 000	1 000
J	mm	3 430	3 430
K	mm	3 685	3 685
O	°	55	55
P	°	45	45
R	°	45	45
S	°	75	75
U	mm	255	255
X	mm	1 750	1 750
Y	mm	2 150	2 150
Z	mm	3 445	3 360
a ₂	mm	4 745	4 745
a ₃	mm	2 555	2 555
a ₄	°	40	40

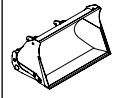

With Loading Fork		TPV attachment bracket	TPV Attachment bracket Long Boom	TPZ attachment bracket	TPZ Attachment bracket Long Boom
					
Center of gravity 500 mm					
A	mm	785	1 135	650	1 020
B	mm	1 475	1 745	1 375	1 645
C	mm	650	825	550	725
D	mm	1 705	1 705	1 740	1 740
E	mm	3 490	3 695	3 530	3 735
F	mm	4 225	4 430	4 265	4 470
Tipping load full turn (ISO 14397)		kg	4 420	3 920	4 670
Working load acc. to EN 474-3, 60/80 %		kg	2 650 / 3 530	2 350 / 3 130	2 800 / 3 730
Working load 80%, transport position, 40 deg. and full turn		kg	4 000	-	4 000

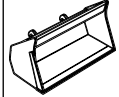
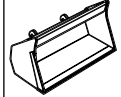
		GENERAL PURPOSE		LIGHT MATERIAL		4-in-1	High-Tip	LONG BOOM
								
With TP-Linkage,TPV attachment bracket and 15.5-25 tires								
Capacity heaped	m ³	1.4	1.5	1.8	2.0	1.2	2.0	-
Material density	kg/m ³	1 800	1 700	1 400	1 200	1 900	1 000	-300
Static tipping load. straight (ISO 14397)	kg	5 940	5 860	5 710	5 600	5 580	4 880	-
Static tipping load. full turn 40° (ISO 14397)	kg	5 250	5 190	5 050	4 960	4 940	4 320	-640
Hydraulic lifting capacity. max.	kN	70	69	68	66	67	58	-
Breakout force	kN	71	69	62	56	77	-	-
A Total length	mm	6 370	6 385	6 505	6 615	6 295	6 955	-
L Lift height. max.	mm	4 740	4 790	4 810	4 940	4 815	5 695	200
V Bucket width	mm	2 250	2 250	2 250	2 250	2 250	2 250	-
a ₁ Clearance circle	mm	10 310	10 320	10 390	10 460	10 305	10 675	-
T Digging depth	mm	85	85	85	85	120	95	-
H Dump height. 45°	mm	2 800	2 780	2 690	2 610	2 790	4 230	200
M Reach at max. height	mm	940	960	1 040	1 115	830	1 500	170
N Reach. max.	mm	1 770	1 785	1 860	1 935	1 650	2 685	270
Operating weight	kg	8 770	8 790	8 800	8 830	8 990	9 230	-

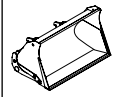



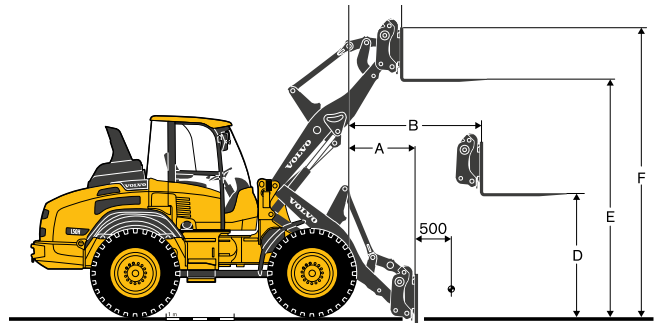
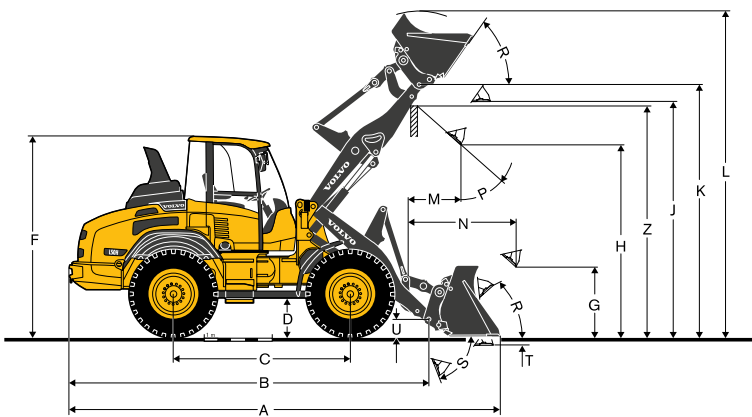
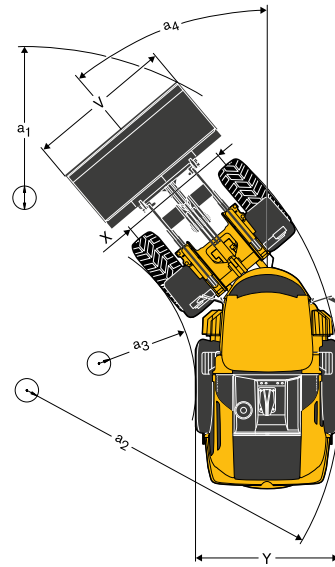

		GENERAL PURPOSE		LIGHT MATERIAL		4-in-1	High-Tip	LONG BOOM
								
With TP-Linkage,TPZ attachment bracket and 15.5-25 tires								
Capacity heaped	m ³	1.4	1.6	1.8	2.0	1.3	2.0	-
Material density	kg/m ³	1 900	1 600	1 400	1 300	1 900	1 100	-300
Static tipping load. straight (ISO 14397)	kg	6 220	6 120	6 020	5 890	6 050	5 260	-
Static tipping load. full turn 40° (ISO 14397)	kg	5 500	5 420	5 330	5 210	5 350	4 650	-640
Hydraulic lifting capacity. max.	kN	74	73	71	70	72	62	-
Breakout force	kN	66	61	56	50	65	-	-
A Total length	mm	6 260	6 335	6 415	6 525	6 270	6 825	-
L Lift height. max.	mm	4 680	4 750	4 820	4 890	4 730	5 610	200
V Bucket width	mm	2 250	2 250	2 250	2 250	2 250	2 250	-
a ₁ Clearance circle	mm	10 125	10 165	10 210	10 275	10 165	10 590	-
T Digging depth	mm	90	90	90	90	45	80	-
H Dump height. 45°	mm	2 875	2 815	2 755	2 675	2 865	4 140	200
M Reach at max. height	mm	860	900	955	1 030	850	1 370	170
N Reach. max.	mm	1 685	1 725	1 780	1 855	1 670	2 540	240
Operating weight	kg	8 670	8 710	8 700	8 730	8 920	9 120	-

Specifications L50H

With TP-linkage, TPV attachment bracket and 17.5-25 tires		
B	mm	5 380
C	mm	2 650
D	mm	435
F	mm	2 980
G	mm	1 000
J	mm	3 525
K	mm	3 780
O	°	54
P	°	45
R	°	44
S	°	76
U	mm	255
X	mm	1 730
Y	mm	2 190
Z	mm	3 535
a ₂	mm	4 760
a ₃	mm	2 540
a ₄	°	40



With Loading Fork		TPV attachment bracket	TPV Attachment bracket Long Boom
Center of gravity 500 mm			
A	mm	800	1 060
B	mm	1 505	1 705
C	mm	655	785
D	mm	1 745	1 745
E	mm	3 585	3 735
F	mm	4 320	4 470
Tipping load full turn (ISO 14397)	kg	4 810	4 410
Working load acc. to EN 474-3, 60/80%	kg	2 880 / 3 840	2 640 / 3 520
Working load 80%, transport position, 40 deg. and full turn	kg	4 000	-

		GENERAL PURPOSE		LIGHT MATERIAL		4-in-1	High-Tip	LONG BOOM
								
With TP-Linkage,TPV attachment bracket and 15.5-25 tires								
Capacity heaped	m ³	1.5	1.6	1.8	2.0	1.4	2.3	-
Material density	kg/m ³	1 900	1 700	1 500	1 300	1 900	1 000	-250
Static tipping load. straight (ISO 14397)	kg	6 560	6 510	6 400	6 290	6 080	5 550	-
Static tipping load. full turn 40° (ISO 14397)	kg	5 810	5 750	5 670	5 570	5 390	4 910	-510
Hydraulic lifting capacity. max.	kN	87	86	85	83	82	73	-
Breakout force	kN	72	69	64	58	65	-	-
A Total length	mm	6 460	6 495	6 580	6 690	6 560	7 030	-
L Lift height. max.	mm	4 880	4 900	4 980	5 235	4 905	5 915	150
V Bucket width	mm	2 250	2 250	2 250	2 250	2 250	2 250	-
a ₁ Clearance circle	mm	10 360	10 385	10 435	10 505	10 475	10 740	-
T Digging depth	mm	95	95	95	95	130	105	-
H Dump height. 45°	mm	2 865	2 845	2 775	2 695	2 745	4 330	-
M Reach at max. height	mm	965	1 000	1 040	1 115	965	1 505	130
N Reach. max.	mm	1 810	1 830	1 890	1 970	1 810	2 710	200
Operating weight	kg	9 480	9 500	9 490	9 520	9 740	9 960	-

Equipment

STANDARD EQUIPMENT

	L45H	L50H
Engine		
Dry-type air filter	•	•
Three stage air cleaner, pre-cleaner, primary and secondary filter	•	•
Preparation for pre-cleaner	•	•
Preheating of induction air	•	•
Side by side (single layer) cooling pack	•	•
Coolant level monitoring	•	•
Filtration screens on air inlets	•	•
Fuel pre-filter with water trap	•	•
Crank case breather oil trap	•	•
Exhaust after-treatment system	•	•
Exhaust heat ventilation	•	•
Drivetrain		
Hydrostatic drive	•	•
Inching-brake pedal (hydrostatic wearless braking ahead of service brake application)	•	•
Wet disc service brakes, hydraulically operated	•	•
Dry disc parking brake	•	•
Operator-selected 100% differential locks in both axles	•	•
Electrical system		
24 V electrical system (2 X 12V maintenance free batteries)	•	•
Batteries covered by lockable engine hood	•	•
Electronic battery cut-off switch	•	•
Alternator 110 A / 3 080 W	•	•
Electric horn	•	•
Hydraulic system		
Load-Sensing Hydraulics	•	•
Flow sharing main control valve, three-spool system	•	•
Variable displacement axial piston pump for working hydraulic and steering	•	•
Gear pump for brake system and cooling fan	•	•
3rd hydraulic circuit	•	•
Bucket positioner	•	•
Indicator glass for hydraulic oil level	•	•
Thermostatically controlled oil flow to oil cooler (fast warm-up, optimized cooling)	•	•
Lights		
Main head lights (halogen) upper/dipped/asymmetrical	•	•
Working lights, halogen (2 front/2 rear)	•	•
Parking lights	•	•
Rear lights	•	•
Brake lights	•	•
Direction indicators	•	•
Hazard warning lights	•	•
Reversing lights	•	•
Cab lighting	•	•
Service		
Standard tool kit	•	•
Drain valves for engine oil, hydraulic oil and coolant	•	•
Hydraulic pressure test ports with quick-connects	•	•
Instrumentation & controls		
24 Volt accessories socket	•	•
Hazard warning switch	•	•
Safety start	•	•
Electronic Information System		
Contronic display with keypad	•	•
Monitoring of fuel level, fuel consumption, AdBlue level, temperatures and pressures (engine, ambient, transmission, hydraulics, brakes and steering)	•	•
LED-illuminated symbols are available for direction indicators, transportation & work lights, rotating beacon, parking brake, engine oil pressure, battery charging, differential lock, boom suspension system, Adblue warning, regeneration and high exhaust temperature	•	•
Cab, Exterior		
ROPS/FOPS-cab	•	•
Cab cushioning	•	•
Single key kit door / start	•	•
Lockable door	•	•
Door stops	•	•
All-round tinted safety glass	•	•
Sliding window RHS	•	•
Two-stage air inlet filtration with large easy to replace elements	•	•
External rear view mirrors (right/left)	•	•
Windscreen wiper (front/rear)	•	•
Windscreen washer (front/rear)	•	•

STANDARD EQUIPMENT

	L45H	L50H
Cab, Interior		
Acoustic inner lining	•	•
Floor mat	•	•
Adjustable steering column	•	•
Left and right armrests	•	•
4-way adjustable operator's seat	•	•
Retractable seat belt	•	•
Sunvisor	•	•
Interior rear view mirrors	•	•
Air conditioner	•	•
Automatic heat control	•	•
Several air vents on the front and rear of the cab, allowing excellent climate control, demisting and defrosting	•	•
Interior light	•	•
Coat hook	•	•
Cup holder	•	•
Storage box in the cab	•	•
24 V power outlet	•	•
Emergency hammer	•	•
Working Equipment		
Automatic bucket positioner	•	•
Hydraulic quick-change attachment bracket	•	•
External equipment		
Fenders (front/rear)	•	•
Lockable engine hood	•	•
Lockable fuel-tank cap	•	•
Lockable AdBlue filler cap	•	•
Vertical exhaust	•	•
Frame, joint lock	•	•
Towing device	•	•
Lifting eyes and Tie-down points	•	•
Official approval		
Machine conforming to European directive 2006/42/EC	•	•
Electromagnetic compatibility (EMC) conforming to European directive 2014/30/EC	•	•
Noise emissions in the environment conforming to directive 2000/14/EC	•	•
Tipping load and payload conforming to ISO 14397-1	•	•
ROPS conforming to ISO 3471	•	•
FOPS conforming to ISO 3449	•	•
Optional Equipment		
	L45H	L50H
Engine		
Fuel preheater	•	•
Handthrottle	•	•
Automatic engine shutdown	•	•
Turbo II Prefilter	•	•
Air pre-cleaner, oil-bath type	•	•
Fan speed, high ambient	•	•
Reversible cooling fan	•	•
Engine Block heater, 120 V / 230 V	•	•
Other attachments		
Log grapples	•	•
Forks	•	•
Material handling arm	•	•
Drivetrain		
Hand-inching	•	•
20 km/h version	•	•
30 km/h version	•	•
Electric		
Rotating beacon foldable	•	•
Preparation for magnetic rotating beacon	•	•
Magnetic rotating beacon	•	•
Reverse alarm audible	•	•
Reverse alarm audible & switchable	•	•
Reverse alarm audio visual switchable	•	•
Rear view camera incl monitor (color)	•	•
LED Working lights on cab, 2 front / 2 rear	•	•
LED Working lights on cab, 4 front / 4 rear	•	•
Additional LED Working lights, 2 front / 1 rear	•	•
Elevated headlights 350 mm	•	•
Road light equipment width 2.5 m	•	•
Power outlet 12 V	•	•
Anti theft device	•	•
Care Track GSM	•	•
Care Track Satellite	•	•

Optional Equipment	L45H	L50H
Hydraulics		
Hyd oil mineral VG46 HV	•	•
Hyd oil mineral VG32 HV	•	•
Hyd oil mineral VG68 HV	•	•
Hyd oil bio synthetic VG46	•	•
Boom suspension system	•	•
Boom kickout	•	•
Safety valve for lift cylinder	•	•
Tilt control	•	•
Tilt speed limiter mechanical	•	•
Safety valve for tilt cylind.	•	•
4th function	•	•
Hydr. Couplings	•	•
High flow (125 l/min)	•	—
High flow (140 l/min)	—	•
Auxiliary hydraulic's return line (via filter)	•	•
Cab		
Door all glass	•	•
Door with sliding window	•	•
Foldable right hand window	•	•
Split door (Door with foldable window)	•	•
Heated rearview mirrors	•	•
Seat fab air/susp heat	•	•
Seat mec/susp	•	•
Seat belt 3"	•	•
Seat belt warning	•	•
Comfort drive control (CDC)	•	•
Radio preparation 12 V	•	•
Radio	•	•
Joystick control including F/R/N, up/down-shift, differential lock and 3rd hydraulic function	•	•
Multilever control, including F/R/N, up/down-shift, differential lock, horn and 3rd hydraulic function	•	•
Multilever control, including F/R/N, up/down-shift, differential lock, horn, 3rd & 4th hydraulic function	•	•
Timer cab heating (Pause heating)	•	•
Auxiliary cab & engine heater	•	•

Optional Equipment	L45H	L50H
Service		
Wheel chock	•	•
Tool Kit	•	•
Central Lub unit (Volvo)	•	•
Wheel/Tires		
440/80R24	•	•
500/70R24	•	•
540/65R24	•	—
15.5R25	•	•
17.5R25	•	•
550/65R25	•	•
600/55-26.5	•	•
Protective equipment		
Front Mudflaps	•	•
Extended mudflaps	•	•
Mudguard extension 75 mm	•	•
Belly guards, front/rear	•	•
Rear lights protection	•	•
Headlights protection	•	•
Working lights guards, front/rear	•	•
Windshield guard, rear	•	•
Windshield guard, front	•	•
Engine hood protection	•	•
Other		
Long boom	•	•
Preparation for licence plate	•	•
Side marking reflectors	•	•
SMV warning triangle	•	•
Trailer socket	•	•
Colour Level 1 (yellow parts)	•	•
Colour Level 1+2	•	•
Attachments / Buckets		
Straight with teeth and bolt on edges	•	•
High tipping	•	•
Light material	•	•
Clamp	•	•

SELECTION OF VOLVO OPTIONAL EQUIPMENT

Boom suspension system



Comfort Drive Control



Reversible cooling fan



3rd & 4th hydraulic function



Auxiliary cab & engine heater



Central lubrication system



Not all products are available in all markets. Under our policy of continuous improvement, we reserve the right to change specifications and design without prior notice. The illustrations do not necessarily show the standard version of the machine.

VOLVO

Volvo Construction Equipment

www.volvoce.com