

V O L V O



For Volvo Wheel Loaders L60–L350

ATTACHMENTS

Volvo Construction Equipment



Table of content

- Why choose Volvo Attachments?page 4
- Volvo Attachment bracketpage 6
- Shaped to perform bucketspage 8
 - o Volvo Rock buckets.....page 10
 - o Volvo Slag buckets.....page 16
 - o Volvo Rehandling bucketspage 18
 - o Volvo General Purpose buckets.....page 22
 - o Volvo High-Tip buckets.....page 28
 - o Volvo Light Material bucketspage 32
 - o Volvo Refuse bucketspage 34
 - o Volvo Grading buckets.....page 38
 - o Wear partspage 40
- Range of forkspage 42
 - o Volvo Pallet Fork Frame.....page 44
 - o Volvo Fork Tinespage 46
 - o Volvo Fork Tine Lumber.....page 48
 - o Volvo Separate Fork Back Extendpage 48
 - o Volvo Fork Frame with side shift and fork positionerpage 50
 - o Volvo Side Shift Tines.....page 50
 - o Volvo Stone fork.....page 52
 - o Volvo Block forkpage 52
 - o Volvo Breaker Tinepage 54
 - o Volvo Rakepage 54
- Grapple for all jobs.....page 56
 - o Volvo Unloading grapplepage 58
 - o Volvo Sorting grapplepage 59
 - o Volvo Heel/Kickoutpage 60
 - o Volvo General Purpose grapplepage 61
 - o Volvo High-Lift grapples.....page 62
- Log pusher.....page 64
- Material handling arm.....page 65



WHY CHOOSE VOLVO ATTACHMENTS?

You probably chose a Volvo wheel loader because you wanted the best. So, why settle for less when it comes to the attachments? Only with Volvo Attachments you do get what you wanted when you bought a Volvo in the first place – maximum productivity, fuel efficiency and uptime.

A close-up photograph of a person's hand wearing a blue nitrile glove. The hand is adjusting a circular dial or knob on a piece of heavy-duty metal machinery. The background is dark and out of focus, emphasizing the mechanical details and the precision of the adjustment.

Consistently high quality

Volvo attachments are recognized within the industry for their durability and performance. We set ourselves the strictest standards when it comes to quality and every single product is controlled and approved according to our exacting requirements.

Experienced product development

Our in-house expert team works tirelessly, day after day, to develop new attachment solutions and optimize our existing range. This focus comes from our commitment to continually improve the output of your operation.

High precision welding

As a company committed to the highest standards of quality, we put significant focus on welding performance and use the very latest in robot welding technology to secure best in class products.

Custom-Built Attachments

When your application requires a unique attachment design, Volvo is on hand to support you. We can help you define the right attachment design, matched to your precise requirement.

Volvo Attachment Bracket

With many jobs requiring more than one attachment, Volvo provides you with a tool that turns your wheel loader into a real all-rounder. First introduced by Volvo in 1954, the ISO standardized attachment bracket enables the quick, easy and safe switching between attachments. At the touch of a button, you can lock and unlock the attachment to the bracket without leaving your seat – all while benefitting from outstanding visibility.

Volvo Attachment Brackets	Products								
	L60F/H	L70F/H	L90F/H	L110F/H	L120F/H	L150H	L180H	L220H	L350H
VAB-STD	X	X	X	X	X				
VAB-STD SIDE TILT	X	X	X						
VAB-L						X	X	X	
VAB-BH									X



Standard Volvo attachment bracket



Volvo attachment bracket for large loaders

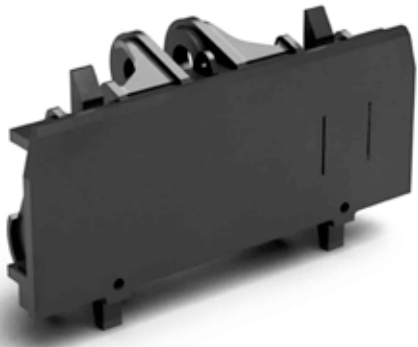

Volvo attachment bracket for block handling

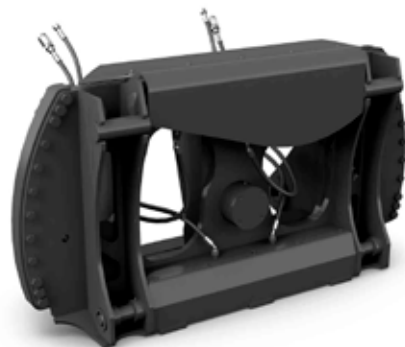

Side tilting Volvo attachment bracket



Shaped to perform buckets

Increase productivity and enhance fuel efficiency by up to 20% with easy-to-operate Volvo buckets. Save time and money by choosing a bucket optimized for your application, available from our extensive range.



Minimized spillage

Optimized spill guards reduce spillage and help to deflect material to protect the machine linkage.

Long-lasting

Built to last, Volvo buckets and wear parts are built using high quality steel. Volvo wear parts are easy to replace and availability of replacement is guaranteed, through our comprehensive parts network.

Quick and easy fill

For improved productivity, the bucket shape, balanced floor back ratio and countersunk holes offer less resistance when penetrating material.

Outstanding performance

As an integrated part of the wheel loader, Volvo buckets deliver precise control and superior productivity.

Safety first

Volvo buckets are designed to deliver the best possible visibility - enhancing safety.



Custom-Built Attachments

Want to improve your productivity and boost performance in a specific application? A customized standard Volvo Attachment could be the answer!

When your application requires a unique attachment design, Volvo is on hand to support you. With Custom Built Attachments, you get support and tailored advice from your Volvo dealer and our in-house attachments specialists. As a total solution provider, we can help you define the right attachment design, matched to your precise requirements and application.

Possible design changes on an existing loader attachment include: Spill guard, Side plates, Bucket floor, Wear protection, Volume, Width and height, Volvo wear parts.

Notes:

Design deviations are only possible on existing Volvo Attachments. Competitor interfaces are not supported by Volvo. Every design deviation needs to match the machine and fulfill legal regulations, including feasibility tests.

Volvo Rock bucket – Spade nose

Specifically designed for harsh rocky conditions, Volvo Rock buckets are reinforced with hardened wear plates, to secure long-lasting performance.

The Spade nose variant is optimized for loading blasted rock or easily broken material.



Spade nose maximizes penetration
Design applies to L260 and L350.

The attachment design may vary depending on machine model.

Note: Wear parts can be found on page 38

Volvo Rock bucket with spade nose | Hook-on interface

Capacity*	Width	Products							
		L60F/H	L70F/H	L90F/H	L110F/H	L120F/H	L150H	L180H	L220H
1.6	2 500	x							
1.8	2 550		x						
2.2	2 650			x					
2.9	2 880				x	x			
3.4	3 230								
4.1	3 230							x	
4.4	3 430								x

Volvo Rock bucket with spade nose | Pin-on interface

Capacity*	Width	Products								
		L70F/H	L90F/H	L110F/H	L120F/H	L150H	L180H	L220H	L260H	L350H
1.8	2 550	x								
2	2 650		x							
2.2	2 650		x							
2.6	2 880				x	x				
2.9	2 880				x	x				
3.4	3 230						x			
3.2	2 880					x				
3.7	3 230							x		
4.1	3 230							x		
4.4	3 430								x	
4.9	3 430								x	
4.9	3 650									x
5.4	3 650									x
5.9	3 650									x
6.3	3 650									x
6.4	4 110									x
6.8	4 110									x
7.3	4 110									x
7.6	4 110									x

*Heaped ISO/SAE volume without wear parts. Bolt-on edge and segments add 0.1 m³.



Volvo Rock bucket – Straight edge

The Straight edge variant features higher break-out force and increased dump clearance compared to the Spade nose variant.

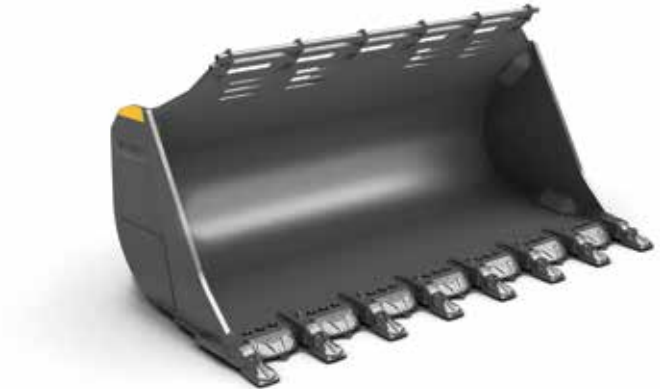

High dump clearance for quick and easy filling.

Design applies to L260 and L350.

The attachment design may vary depending on machine model.

Note: Wear parts can be found on page 38

Volvo Rock bucket with straight edge | Pin-on interface

Capacity*	Width	Products						
		L110F/H	L120F/H	L150H	L180H	L220H	L260H	L350H
3.0	2 880	x	x					
3.6	3 030			x				
3.6	3 230			x				
4.2	3 200				x			
4.2	3 230				x			
4.3	3 430					x		
5.3	3 650						x	
5.7	3 650						x	
6.2	3 970							x
6.6	3 970							x

*Heaped ISO/SAE volume without wear parts. Bolt-on edge and segments add 0.1-0.3 m³.



Volvo Rock bucket – Block Handler

Built using wear resistant steel, the Volvo Block Handler Rock bucket is optimized for carrying blocks and loading overburden in block quarries, engineered to deliver outstanding durability in quarry environments.

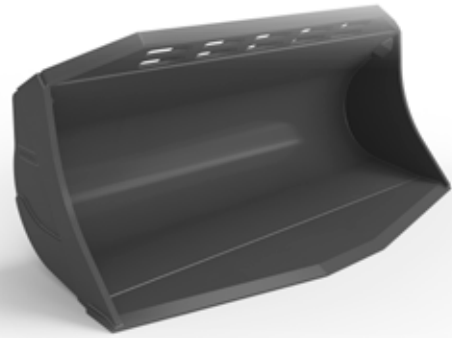

High tensile steel and wear resistant parts are positioned in critical areas.

Note: Wear parts can be found on page 38



Volvo Rock bucket - Block handler Hook-on interface		
Capacity*	Width	Products
m ³	mm	L350H
6.2	3 960	x

*Dimensions based on Volvo 55 AMRL point. Other points may affect dimensions differently.

Volvo Rock bucket – Side Dump

Volvo Side Dump Rock bucket is designed for sideways dumping in tight locations, such as tunnels. The smart design is easy to operate and features reinforced parts, in the most exposed areas.



Tilting functionality allows efficient work in confined environments.
Design applies to L260
The attachment design may vary depending on machine model.

Note: Wear parts can be found on page 38



Volvo Side Dump Rock bucket with spade nose | Pin-on interface

Capacity*	Width	Products				
		L150H	L180H	L220H	L260H	L350H
3.4	3 566	x				
3.8	3 566		x			
4.1	3 713			x		
5.5	3 730				x	
6.5	4 210					x

*Heaped ISO/SAE volume without wear parts. Bolt-on edge and segments add 0.1 m³.

Volvo Slag bucket

Specially designed for hot slag applications, the Volvo Slag bucket is manufactured to withstand extremely high temperatures and abrasion.

Using the slag bucket as a starting point, through our Custom Built Attachments program we can tailor the optimum bucket specification for your operation.



Made from high quality steel and featuring extensive reinforcements throughout

Volvo Slag bucket | Pin-on interface

Capacity m ³	Width mm	L150H	L180H	L220H	L260H	L350H
3.9	3 230	x				
4.1	3 230		x			
4.6	3 430			x		
5.3	3 580				x	
6.8	3 980					x





Volvo Rehandling bucket – Straight edge

Volvo Rehandling buckets are the perfect choice for handling medium-sized processed material, no matter if you are doing truck loading, loading crusher/screener, stockpiling or a load and carry task.

The Straight edge variant ensures the highest levels of break-out force and dump clearance, compared to its spade nose alternative.



Optimized spill guards, curved side plates = optimum bucket fill & material retention
Straight edge = highest levels of break-out force & dump clearance

Note: Wear parts can be found on page 38

Volvo Rehandling bucket | Hook-on interface

Capacity*	Width	Products				
		L110F/H	L120F/H	L150H	L180H	L220H
3.1	3 000	x	x			
3.4	2 880	x	x			
3.4	3 000	x	x			
3.7	2 880		x			
3.7	3 000		x			
4.6	3 200			x	x	
5.0	3 400			x	x	
5.6	3 400				x	x
6.1	3 400					x

Volvo Rehandling bucket | Pin-on interface

Capacity*	Width	Products						
		L110F/H	L120F/H	L150H	L180H	L220H	L260H	L350H
3.1	3 000	x	x					
3.4	2 880	x	x					
3.4	3 000	x	x					
3.7	2 880		x					
3.7	3 000		x					
3.8	3 200			x				
4.2	3 200			x				
4.5	3 000			x				
4.6	3 200			x	x			
5.0	3 400			x	x			
5.3	3 400				x			
5.6	3 400				x			
5.4	3 400					x		
5.7	3 400					x		
6.1	3 400					x		
5.9	3 580						x	
6.7	3 580						x	
7.1	3 650						x	
8.5	3 970							x
9.1	3 970							x
10.4	3 970							x

*Heaped ISO/SAE volume without wear parts. Bolt-on edge and segments add 0.1-0.3 m³.

Volvo Rehandling bucket – Spade nose

The Spade nose variant is designed to deliver higher penetration than the straight edge version, contributing to faster cycle times and making it the perfect choice when working with larger processed material.



Spade nose maximizes penetration

Note: Wear parts can be found on page 38



Volvo Rehandling bucket - Spade nose | Hook-on interface

Capacity*	Width	Products			
m ³	mm	L120H	L150H	L180H	L220H
3.7	3 000	X			
5.0	3 400		X	X	
5.6	3 400			X	X
6.1	3 400				X

Volvo Rehandling bucket - Spade nose | Pin-on interface

Capacity*	Width	Products
m ³	mm	L260H
6.7	3 580	X

*Heaped ISO/SAE volume without wear parts. Bolt-on edge and segments add 0.1 m³.

Volvo Rehandling bucket – Flat Floor

Optimized for soft underfoot conditions, the Flat Floor variant is the best choice for handling sand, gravel and aggregate. Maximize traction and break-out force, while maintaining a clean and level work area, for unbeatable productivity and efficiency.



Flat floor design with minimized pockets.

Note: Wear parts can be found on page 38



Volvo Rehandling bucket - Flat Floor | Hook-on interface

Capacity*	Width mm	Products				
		L110F/H	L120F/H	L150H	L180H	L220H
3.3	3 000	x	x			
3.7	3 000		x			
4.6	3 200			x		
5.0	3 400				x	
5.6	3 400					x
6.1	3 400					x

Volvo Rehandling bucket - Flat Floor | Pin-on interface

Capacity*	Width mm	Products					
		L110F/H	L120F/H	L150H	L180H	L220H	L260H
3.3	3 000	x	x				
3.7	3 000		x				
5.0	3 400			x			
5.6	3 400				x		
6.1	3 400					x	
7.1	3 650						x

*Heaped ISO/SAE volume without wear parts. Bolt-on edge and segments add 0.1-0.3 m³.

Volvo General Purpose bucket – Standard

Volvo General Purpose buckets are the best choice for all-round efficiency. The Standard duty variant is primarily designed for use in low-impact operations, when working with moderately abrasive materials such as dirt, loam, gravel, and clay.



Reflective stickers boost visibility for quick and easy filling.

Note: Wear parts can be found on page 38

Volvo General Purpose bucket - Standard | Hook-on interface

Capacity*	Width	Products				
		L60F/H	L70F/H	L90F/H	L110F/H	L120F/H
1.8	2 500	x				
2	2 500	x	x			
2.2	2 500	x	x			
2.5	2 750			x		
2.7	2 750			x		
2.8	3 000				x	x
3	3 000				x	x
3.3	3 000				x	x

*Heaped ISO/SAE volume without wear parts. Bolt-on edge and segments add 0.1 m³.



Volvo General Purpose bucket – Heavy-Duty

For increased durability, the Heavy-Duty variant is reinforced with wear resistant steel. The bucket is typically equipped with either a bolt-on edge or teeth and segments.



HB400 and HB500 steel used in the most exposed areas, including the bucket floor.

Design applies to L260-L350.

The attachment design may vary depending on machine model.

Note: Wear parts can be found on page 38

Volvo General Purpose bucket - Heavy-Duty | Hook-on interface

Capacity*	Width	Products							
		L60F/H	L70F/H	L90F/H	L110F/H	L120F/H	L150H	L180H	L220H
1.6	2 500	x							
1.8	2 500	x							
2	2 500	x	x						
2	2 650	x							
2.2	2 500	x	x						
2.2	2 650	x							
2.2	2 750			x					
2.3	2 650		x						
2.4	2 500			x					
2.4	2 750			x					
2.5	2 750			x					
2.6	2 750			x					
2.7	2 750			x					
2.8	2 880				x	x			
3.0	2 880				x	x			
3.3	2 880				x	x			
3.3	3 000				x				
3.0	3 000				x	x			
3.3	2 880					x			
3.3	3 000				x	x			
3.5	3 000					x			
3.5	3 200						x		
3.8	3 000						x		
3.8	3 200						x		
4.2	3 200						x	x	
4.2	3 230						x	x	
4.6	3 200							x	
4.7	3 400								x
5.0	3 400								x

*Heaped ISO/SAE volume without wear parts. Bolt-on edge and segments add 0.1-0.3 m³.



Volvo General Purpose bucket - Heavy-Duty | Pin-on interface

Capacity*	Width	Products									
		L60F/H	L70F/H	L90F/H	L110F/H	L120F/H	L150H	L180H	L220H	L260H	L350H
1.8	2 550	x									
2	2 500	x									
2.2	2 500	x	x								
2.2	2 650		x								
2.3	2 500		x								
2.3	2 650		x								
2.4	2 500			x							
2.4	2 750			x							
2.5	2 500			x							
2.5	2 750			x							
2.5	2 880				x	x					
2.6	2 750			x							
2.7	2 750			x							
3.0	2 880				x	x					
3.3	2 880				x	x					
3.0	3 000				x	x					
3.3	3 000				x	x					
3.5	3 000					x					
3.8	3 000						x				
4.0	3 000						x				
4.3	3 000						x				
3.5	3 200						x				
3.8	3 200						x	x			
4.2	3 200						x	x			
4.4	3 200							x			
4.6	3 200							x			
3.8	3 230						x	x			
4.2	3 230							x			
4.4	3 230							x			
4.6	3 230							x			
4.6	3 400							x			
5.0	3 400								x		
5.4	3 400								x		
5.8	3 400								x		
5.0	3 430								x		
5.4	3 430								x		
5.5	3 580									x	
6.2	3 580									x	
6.6	3 650									x	
7.0	3 970										x
7.4	3 970										x
8.1	3 970										x

*Heaped ISO/SAE volume without wear parts. Bolt-on edge and segments add 0.1-0.3 m³.

Volvo General Purpose bucket – Flat Floor

The Flat Floor variant is designed for soft underfoot conditions and earth moving applications such as landscaping, stripping topsoil and grading. Move more material and reduce your cycle times with the smart bucket design, which offers maximum traction and break-out force, while maintaining a clean and level work area.



The flat floor design contributes to a better bucket fill and increased productivity.

Note: Wear parts can be found on page 38

Volvo General Purpose bucket - Flat Floor | Hook-on interface

Capacity*	Width	Products				
		L60F/H	L70F/H	L90F/H	L110F/H	L120F/H
1.9	2 500	x				
2.3	2 550		x			
2.5	2 650		x	x		
3	2 880				x	x
3.4	2 880					x

Volvo General Purpose bucket - Flat Floor | Pin-on interface

Capacity*	Width	Products				
		L60F/H	L70F/H	L90F/H	L110F/H	L120F/H
1.9	2 500	x				
2.3	2 550		x			
3.0	2 880				x	x
3.4	2 880					x
4	3 000					

*Heaped ISO/SAE volume without wear parts. Bolt-on edge and segments add 0.1 m³.

Volvo General Purpose bucket - Heavy-duty Flat Floor | Pin-on interface

Capacity*	Width	Products		
		L110F/H	L120F/H	L150H
3	2 880	x	x	
3.4	2 880	x	x	
4.1	3 000			x

*Heaped ISO/SAE volume without wear parts. Bolt-on edge and segments add 0.1 m³.

Volvo General Purpose Heavy Duty Short Floor bucket - Pin-on interface

Capacity*	Width	Products	
		L150H	L180H
4.3	3 000	x	
4.6	3 400		x

*Heaped ISO/SAE volume without wear parts. Bolt-on edge and segments add 0.1 m³.



Volvo High Tip bucket – Center-mounted Cylinders

Hydraulically lifted from a built-in frame, Volvo High Tip buckets feature an increased dump height compared to standard light material buckets. These high capacity tipping buckets are the right choice when handling loose light material.

The Center-mounted Cylinders variant is ideal to load grain and wood chips.



Light frame weight for high load volumes.
The attachment design may vary depending on machine model.

Note: Wear parts can be found on page 38

Volvo High-Tip bucket with center mounted cylinders | Hook-on interface

Capacity*	Width	Products							
		L60F/H	L70F/H	L90F/H	L110F/H	L120F/H	L150H	L180H	L220H
3.2	2 650		x						
3.8	2 750			x					
4.8	2 650	x							
5	3 000				x	x			
6	2 750		x						
6	3 200						x	x	
7	3 000			x	x	x			
7	3 400						x	x	x
9.5	3 400				x	x			
11	3 700						x		x
13	4 000							x	x

Volvo High-Tip bucket with center mounted cylinders | Pin-on interface

Capacity*	Width	Products							
		L60F/H	L70F/H	L90F/H	L110F/H	L120F/H	L150H	L180H	
3.2	2 650		x						
3.8	2 750			x					
4.8	2 650	x							
5	3 000				x	x			
6	3 200						x	x	
7	3 000			x	x	x			
7	3 400						x	x	
9.5	3 400				x	x			
11	3 700						x	x	
13	4 000							x	

*Heaped ISO/SAE volume.



Volvo High Tip bucket – Side-mounted Cylinders

Specifically intended for waste and recycling applications, the Side-mounted Cylinders variant is designed to handle higher density material like refuse and compost. The horizontal cylinders with damping function enable quick and smooth tilting, while steel cover plates, easy-to-access external grease points and perfect hydraulic hose protection contribute to long-lasting performance. Compatible with long boom. Standard bolt-on edge.



The low cylinder box supports easy material penetration.

Note: Wear parts can be found on page 38

Volvo High-Tip bucket with side mounted cylinders | Hook-on interface

Capacity*	Width	Products				
		L60F/H	L70F/H	L90F/H	L110F/H	L120F/H
2.5	2 550	x				
3	2 750	x				
3.5	2 750		x			
4	3 000			x		
4.5	3 000			x	x	
5	3 000				x	x
5.5	3 000					x

Volvo High-Tip bucket with side mounted cylinders | Pin-on interface

Capacity*	Width	Products				
		L60F/H	L70F/H	L90F/H	L110F/H	L120F/H
4	3 000			x		
4.5	3 000			x	x	
5	3 000				x	x
5.5	3 000					x

*Heaped ISO/SAE volume.



Volvo Light Material bucket – Low Density

Volvo Light Material buckets are the largest capacity Volvo bucket. Featuring the best possible visibility and dumping angle, they are tailored to deliver superior performance when loading light and loosely-packed material.



The Low Density variant is recommended to handle coal, sugar beets and compost.

Note: Wear parts can be found on page 38



Volvo Light Material bucket - Low density | Pin-on interface

Capacity*	Width	Products									
		L60H/F	L70H/F	L90H/F	L110F/H	L120F/H	L150H	L180H	L220H	L260H	L350H
m ³	mm										
3.1	2 550	x									
3.4	2 650		x								
4.1	2 750			x							
5.5	3 000				x	x					
5.7	3 200						x				
6.8	3 200						x	x			
7.8	3 400							x			
8.2	3 700								x		
9.5	3 700							x	x		
10.2	3 700									x	
12.7	4 500										x

Volvo Light Material bucket - Low density | Hook-on interface

Capacity*	Width	Products								
		L60H/F	L70H/F	L90H/F	L110F/H	L120F/H	L150H	L180H	L220H	
m ³	mm									
3.1	2 550	x								
4.1	2 750			x						
5.5	3 000					x				
6.8	3 200						x	x		
7.8	3 400							x		
8.2	3 700								x	
16.0	4 500									x

*Heaped ISO/SAE volume.

Volvo Light Material bucket – Very Low Density

The Very Low Density variant is the right choice when handling materials such as grain and woodchips.



Extra curved side plates can double the capacity of the bucket. Added holes in the design ensure visibility.

Note: Wear parts can be found on page 38



Volvo Light Material bucket - Very low density | Pin-on interface

Capacity*	Width	Products					
		L60H/F	L70H/F	L90H/F	L110F/H	L120F/H	L150H
m ³	mm						
5	2 650	x					
9.5	3 700						x
12	3 700						x

Volvo Light Material bucket - Very low density | Hook-on interface

Capacity*	Width	Products							
		L60H/F	L70H/F	L90H/F	L110F/H	L120F/H	L150H	L180H	L220H
m ³	mm								
5	2 650	x							
6.4	2 750		x						
7	3 000			x					
9.5	3 400				x	x			
12	3 700						x		
14	4 000						x	x	x
16.0	4 500							x	x

*Heaped ISO/SAE volume.

Volvo Refuse bucket

Volvo Refuse buckets are heavy-duty, light material buckets intended for use in recycling applications such as handling refuse material, household garbage and other low-density waste material.



Heavy-duty design.

Note: Wear parts can be found on page 38

Volvo Refuse bucket | Pin-on interface

Capacity*	Width	Products							
		L60H/F	L70H/F	L90H/F	L110F/H	L120F/H	L150H	L180H	L220H
3.1	2 550	x							
3.6	2 550	x							
3.9	2 750			x					
4.1	2 750		x						
4.5	2 750			x					
4.7	2 750		x						
5.3	3 000			x	x	x			
5.5	3 000		x						
5.8	3 000				x	x			
6.6	3 200						x	x	
7.6	3 400						x	x	
8.6	3 700								x
9.3	3 700								x
10.5	3 700								x

Volvo Refuse bucket | Hook-on interface

Capacity	Width	Products							
		L60H/F	L70H/F	L90H/F	L110F/H	L120F/H	L150H	L180H	L220H
3.1	2 550	x							
3.6	2 550	x							
3.9	2 750			x					
4.1	2 750		x						
4.5	2 750			x					
4.7	2 750		x						
5.3	3 000			x	x	x			
5.5	3 000		x						
5.8	3 000				x	x			
6.6	3 200						x	x	x
7.6	3 400						x	x	x
8.6	3 700						x	x	x

*Heaped ISO/SAE volume without wear parts. Bolt-on edge and segments add 0.1 m³.



Volvo Refuse Tamping bucket

The Volvo Refuse Tamping buckets are intended for waste handling at a transfer station. With an extra-long floor and heavy-duty design, these buckets are ideal in push floor operations, for both pushing the material towards and packing (tamping) the material in the container. The buckets are offered with bolt-on steel edge as an option.



The extra long floor provides excellent visibility over the bucket edge.

Note: Wear parts can be found on page 38

Volvo Refuse tamping bucket | Pin-on interface

Capacity*	Width	Products					
		L90H/F	L110F/H	L120F/H	L150H	L180H	L220H
5.2 m ³	3 000 mm	x	x	x			
6.4	3 700				x	x	x

Volvo Refuse tamping bucket | Hook-on interface

Capacity*	Width	Products					
		L90H/F	L110F/H	L120F/H	L150H	L180H	L220H
5.2 m ³	3 000 mm	x	x	x			
6.4	3 700				x	x	x

*Heaped ISO/SAE volume without wear parts. Bolt-on edge and segments add 0.1 m³.

Volvo Refuse Tamping bucket – Clamp Arm

The Clamp Arm variant enables the operator to push approximately 25% more material per load, and also helps to remove material from the truck or the container.



The clamp arm enables to move more material, in less time.

Note: Wear parts can be found on page 38

Volvo Refuse tamping bucket with clamp arm | Pin-on interface

Capacity*	Width	Products					
		L90H/F	L110F/H	L120F/H	L150H	L180H	L220H
5.2 m ³	3 000 mm	x	x	x			
6.4	3 700				x	x	x

*Heaped ISO/SAE volume without wear parts. Bolt-on edge and segments add 0.1 m³.

Volvo Grading bucket

The Volvo Grading bucket is designed to provide optimum results in grading, trenching, slope-cutting and finishing work. Experience unmatched control and excellent visibility over the bucket edge.



The edge on the back side enables grading while reversing.

Note: Wear parts can be found on page 38

Volvo Grading bucket | Hook-on interface

Capacity*	Width	Products				
		L60H/F	L70H/F	L90H/F	L110F/H	L120F/H
1.6	2 500	x				
2.1	2 650	x	x	x		
2.7	2 880		x	x		
2.9	3 000			x	x	x

*Heaped ISO/SAE volume without wear parts. Bolt-on edge and segments add 0.1 m³.



Wear parts

Maintain productivity and machine uptime with a range of readily available Genuine Volvo Parts – all backed by the standard Volvo warranty.

Extend service intervals by up to five times thanks to extra protection added to the bucket. Volvo edges, segments, plates and other wear parts are made of 500 Brinell hard steel. By upgrading from 400 to 500 Brinell, the service life can increase by 70%.



Inside liners

The 8mm thick HB400 wear resistant steel provides excellent wear protection to the inside of the bucket body, perfect for heavy rock applications.



Kickers

Protects tires by pushing rocks to the side while filling the bucket.



Corner shrouds

Useful parts to protect the bottom/side plate edge from wear.



Side shrouds

Protects the side cutter from wear in heavy applications.

Not compatible with Chocky bars.



Chocky bars

Provide a additional wear protection on the top of the side cutter.

Not compatible with Side shrouds.



Bolt-on segment

Bolt-on cast segments offers the best protection of the bucket edge between the adapters. Excellent in heavy duty applications. (BPL)

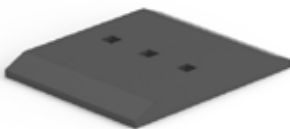

Standard cut segments

Protects the bucket cutting edge between the adapters. Reversible for long service life.



Bolt on edge, straight

Protects and extends the service life of the bucket edge. Three piece reversible for longer service life.



Bolt on edge, spade nose

Protects and extends the service life of the rock bucket edge. Three piece reversible for longer service life.



Bolt-on edge, V-shape

Delivers a outstanding performance, functionality and wear resistance.

Volvo Tooth System

Designed to withstand high force and extreme stress, the teeth, adapter and bucket fit together perfectly to bring strength and resistance and ensure long change intervals. With the new Volvo locking system you can install or change teeth in minutes, helping to minimize downtime. The retainer and the tooth are assembled and supplied together, and no spring replacement is required during the tooth life. What's more, the smart system works with a reusable locking pin, which can be mounted on both sides.

The new generation Volvo Tooth System is a genuinely hammerless solution which requires just a standard square sprocket when installing or changing teeth, reducing the risk of injury.



General purpose

An all-rounder tooth which is suitable for material with a moderate level of abrasion, such as sand and gravel. A small undercut makes it suitable for cleaning work. (GPL)



Abrasive material

This tooth is designed to handle abrasive material where extra penetration is required, such as crushed or blasted rock. Undercuts slightly to give the cutting edge optimum protection. Self sharpening. (AML)



Abrasive material and rock

A tooth for highly abrasive material and rock handling applications, such as blasted rock or hot slag. Focus on long service life, undercuts slightly to give the cutting edge optimum protection. Self-sharpening. (AMRL)



Bolt-on adapter

Two leg adapter bolted to the bucket edge. Gives the cutting edge optimum protection. (BN)



Flush-mounted welded adapter

Flush-mounted weld-on adapter for loader and especially flat floor buckets. Gives the bottom of the bucket a smooth and clean profile. (FC)



Top leg adapter

1½ top leg adapter (long top leg), for welding to both sides of the cutting edge. Excellent in heavy duty applications. (TL)

More information about Volvo CE attachment offer is available in the Attachments selector tool for smart phones.

Available for IOS on App store, for Android on Play Store and China Android Store.

Not all products are available in all markets. Under our policy of continuous improvement, we reserve the right to change specifications and design without prior notice. The illustrations do not necessarily show the standard version of the machine.

Range of forks

For work in material handling yards, warehouses or harbors, Volvo provides the fork attachment, tailor-made to work with your Volvo wheel loader.

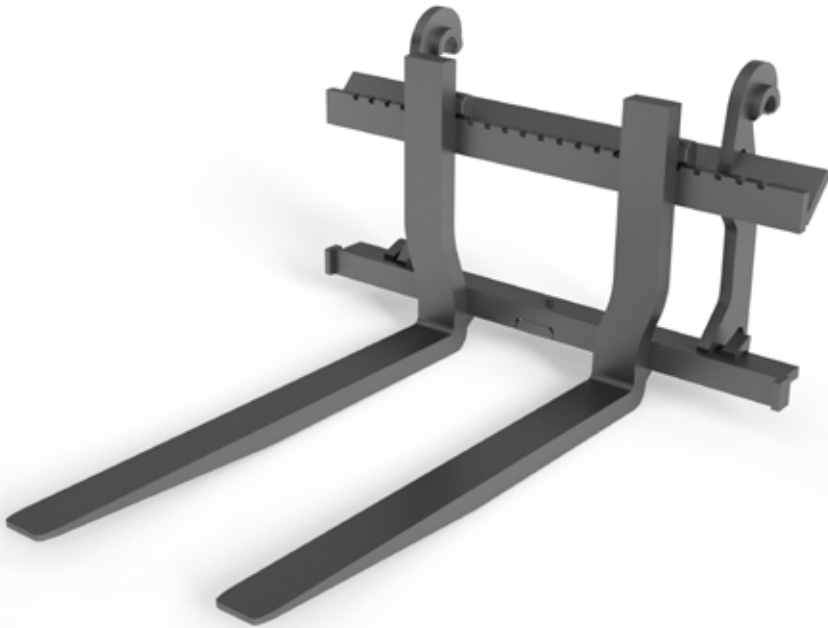

Quality

Fork frames and pallet forks must be able to withstand the full lifting capacity of the machine. Made of high grade, hardened and tempered steel, Volvo forks exceed ISO 2330 requirements.

Stability and reach

Put through extensive testing, Volvo forks offer stability you can count on. Based on decades of experience and engineering excellence, you can depend on the Volvo range when working in the most challenging conditions.

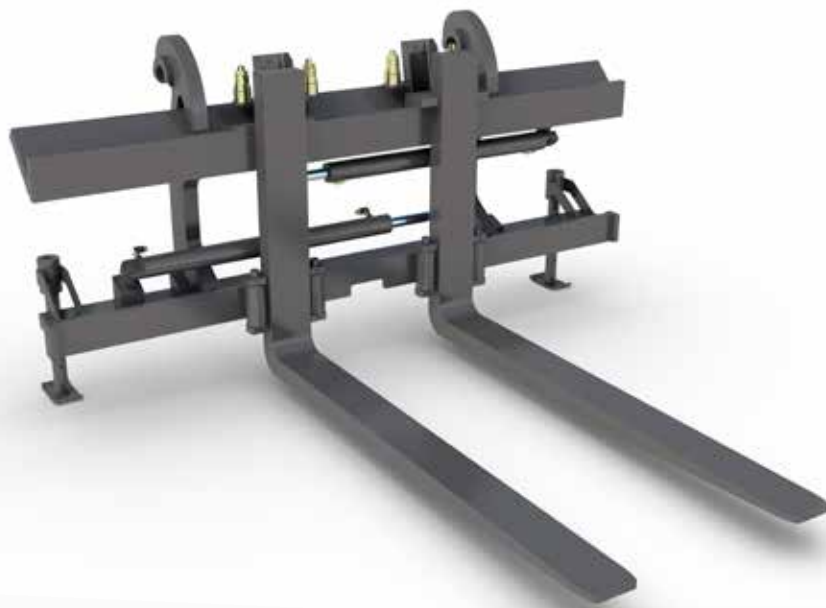

Visibility

The Volvo attachment bracket and fork frames are engineered with visibility in mind, resulting in best-in-class safety and productivity.

Volvo Pallet Fork Frame

With a design optimized to provide excellent visibility in material handling, the Fork Frame can be combined with different fork tines, subframe for floating lumber fork tines and/or separate fork back extension.



Volvo Pallet fork frame

	Width	Weight	Products							
	mm	kg	L60H/F	L70H/F	L90H/F	L110F/H	L120F/H	L150H	L180H	L220H
Standard	1500	200	x	x	x	x	x			
Standard	1500	290			x	x	x			
Standard	2000	245	x	x						
Standard	2200	390			x	x	x			
Standard	2260	500						x	x	x
Heavy-duty	1500	290	x	x						
Heavy-duty	2200	360	x	x						



Volvo Fork Tine – Straight

The Straight Fork Tines are marked in accordance with relevant ISO standards and provide outstanding stability and robustness in heavy, as well as in standard, loading applications.

Fork tine extensions for our standard fork range are available, contact you dealer for more information.



Volvo Pallet fork tines - Straight

	Tine length	Tine width	Products							
	mm	mm	L60H/F	L70H/F	L90H/F	L110F/H	L120F/H	L150H	L180H	L220H
Light duty	1200	130	x	x						
Standard	1200	130	x	x	x	x				
Standard	1200	150				x	x			
Standard	1450	130	x	x	x					
Standard	1450	150				x	x			
Standard	1500	200						x	x	x
Standard	1830	150			x	x	x			
Heavy-duty	1200	150	x	x	x	x	x			
Heavy-duty	1450	150	x	x	x	x	x			
Heavy-duty	1830	150	x	x						
Heavy-duty	2440	150	x	x	x	x	x			
Lumber fork tines	1200	250	x	x	x	x	x			

Volvo Fork Tine – Visibility optimized

The cranked tine design provides outstanding visibility to the end of the Fork Tine. It delivers high performance, high precision handling without damaging the load while picking up.



Volvo Pallet fork tines - Visibility optimized

	Tine length	Tine width	Products				
	mm	mm	L60H/F	L70H/F	L90H/F	L110F/H	L120F/H
Standard	1200	130	x	x			
Standard	1200	150			x	x	x
Standard	1450	130	x	x			
Standard	1450	150			x	x	x
Heavy-duty	1200	150	x	x			
Heavy-duty	1450	150	x	x			
Lumber fork tines	1200	250	x	x	x	x	x

Volvo Fork Tine Lumber

With a design optimized to provide excellent visibility in material handling, the Fork Frame can be combined with different fork tines, subframe for floating lumber fork tines and/or separate fork back extension.



Volvo Pallet fork tine - Lumber

Tine length	Tine width	Products				
mm	mm	L60H/F	L70F/H	L90H/F	L110F/H	L120F/H
1 200	250	x	x	x	x	x

Volvo Separate Fork Back Extend

With a design optimized to provide excellent visibility in material handling, the Fork Frame can be combined with different fork tines, subframe for floating lumber fork tines and/or separate fork back extension.



Volvo Separate fork back extend

Height	Products				
mm	L60H/F	L70F/H	L90H/F	L110F/H	L120F/H
2 150	x	x	x	x	x



Volvo Fork Frame with side shift and fork positioner

The fork tines can be hydraulically adjusted to the width of the load. This system saves significant time while loading material with different load centers, where tine width adjustment is needed.



Volvo Fork frame with side shift

Width mm	Weight kg	Products				
		L60H/F	L70H/F	L90H/F	L110F/H	L120F/H
1 500	370	x	x	x	x	x
2 000	450	x	x	x	x	x

Volvo Side Shift Tines

These are specialized fork tines for the hydraulic side shift fork frame, designed for heavy loads. An additional advantage of this variant is that the operator can adjust the tine width while having a load on the tines.



Volvo Tines - Side shift

Tine length mm	Tine width mm	Products				
		L60H/F	L70F/H	L90H/F	L110F/H	L120F/H
1 200	130	x	x			
1 200	150			x	x	x
1 450	130	x	x			
1 450	150			x	x	x
1 830	150			x	x	x
2 440	150			x	x	x



Volvo Stone Fork

The Stone Fork is designed for lifting and moving stones in quarry applications. To ensure visibility the frame has a very low design which gives the operator a great view to the fork tines.



Volvo Stone fork

Tine length	Tine width	Products					
mm	mm	L90H/F	L110F/H	L120F/H	L150H	L180H	L220H
1 220	160	x	x	x			
1 225	230				x	x	x

Volvo Block Fork

Rugged, dependable, and built to last, Volvo Block Forks are designed for rockhandling and quarry work. Featuring fixed, extra wide, extra thick tines to stand up to the demands of the quarry, the heavy-duty design enables lifting of up to 30 ton blocks.



Volvo Block fork

Tine length	Tine width	Products			
mm	mm	L150H	L180H	L220H	L350H
1 500	300	x	x	x	
1 760	410				x



Volvo Breaker Tine

Single heavy-duty fork tine for breaking out loose blocks in the face and moving heavy raw blocks.



Volvo Breaker tine

Tine length	Tine width	Products			
mm	mm	L150H	L180H	L220H	L350H
900	250	x	x	x	
1 000	300				x

Volvo Rake

The clearing Rake is used for moving blocks and clearing debris. Drawing on our long block handling history, Volvo offers unmatched robustness in our specialized block handling attachments.



Volvo Rake

Rake length	Rake width	Products			
mm	mm	L150H	L180H	L220H	L350H
8 730	2 500	x	x	x	
8 530	2 500				x



A grapple for all jobs

Centuries of timber handling in Sweden have given us the experience and knowledge to design a wide range of superior grapples, helping you reach any log on the stack.



Outstanding work performance

The original Volvo grapple design delivers an optimal work performance to allow work to be completed quickly and safely.



Torque Parallel Linkage

With an unrivalled design, the torque parallel linkage system boosts productivity and delivers high levels safety when using your Volvo wheel loader to stack timber or load a truck.

Volvo Unloading Grapple

These grapples are purpose-design for unloading timber, for example when unloading a vehicle and placing timber in stacks. The grapples have short tines and a clamping arm which gives the grapple a large opening, allowing for an effective and gentle unload.



Note: Can be equipped with hydraulic heel/kickout, found on page 58



Volvo Unloading grapples

Grapple area m ²	Log length m	Grapple width mm	Grapple weight kg	Products					
				L90F/H	L110F/H	L120F/H	L150H	L180H	L220H
1.8	4.8	1630	1400	x	x	x			
2.4	4.8	1630	1550	x	x	x			
3.1	4.8	1800	2 030				x		
3.1	4.8	1830	2 030				x		
3.5	4.8	1830	2 440					x	
3.7	4.8	1830	2 450						x
4	4.8	1830	2 500						x

Volvo Sorting Grapple

The Sorting Grapple has relatively long and straight tines that can slide along the ground so the grapple can be easily filled when loading from stacks and sorting bunkers. Due to the optimized tine design the attachment delivers an outstanding performance while filling. This grapple can also be used for unloading.



Note: Can be equipped with hydraulic heel/kickout, found on page 58



Volvo Sorting grapples

Grapple area	Log length	Grapple width	Grapple weight	Products								
				L60F/H	L70F/H	L90F/H	L110F/H	L120F/H	L150H	L180H	L220H	
1.3	4.8	1 600	1 010	x								
1.5	4.8	1 600	1 100		x							
1.8	4.8	1 630	1 400			x	x	x				
2.4	4.8	1 630	1 590			x	x	x				
3.1	4.8	1 800	2 070						x			
3.1	4.8	1 830	2 360						x			
3.5	4.8	1 830	2 430								x	
3.5	4.8	1 830	2 740								x	
3.7	4.8	1 830	2 500									x
4	4.8	1 830	2 550									x

Volvo Heel/ Kickout

The heel/kickout is available for unloading and sorting grapples. The heel function is used, for example, for holding a single log in a large grapple.

The kick-out function is used to make higher stacks where the grapple cannot be tilted to empty; instead, the logs are pushed out, providing a half meter higher reach.



Available for Volvo Unloading and Sorting grapples



Volvo General Purpose Grapple

The General-Purpose Grapple is an all-round grapple for handling, ideal for sorting tree length stems or for gripping single stems.



Volvo General purpose grapple

Grapple area m ²	Grapple width mm	Grapple weight kg	Products								
			L60F/H	L70F/H	L90F/H	L110F/H	L120F/H	L150H	L180H	L220H	
0.7	1 610	820	x								
0.9	1 600	930		x							
1.3	1 200	1 290			x						
1.3	1 200	1 290				x	x				
1.3	1 630	1 350			x	x	x				
1.8	1 800	1 790							x	x	x

Volvo High-Lift Grapples – Standard

Volvo high lift grapples allow to stay productive across a wide variety of work methods.

The standard log grapple is available with hydraulic clamping arms or clinch chain (double triplex chains), and comes equipped with reversible and replaceable wear plates on the points.



Available for L200H High Lift

Volvo high-lift grapple - Standard

Round shaped	Area	Grapple width	Inner width	Maximum opening width	Weight
	m ²	mm	mm	mm	kg
Clinch chain	3.4	1 100	2 400	3 730	2 260
	3.7	1 100	2 400	3 950	2 310
	4.0	1 100	2 400	4 160	2 380
	4.3	1 100	2 400	4 370	2 430
Clamp arms	3.4	1 100	2 400	3 730	2 800
	3.7	1 100	2 400	3 950	2 870
	4.0	1 100	2 400	4 160	2 990
	4.3	1 100	2 400	4 370	3 070

Volvo High-Lift Grapples – Unload against a wall

Adapted for unloading railway boxcars and short logs loaded across the vehicle, this high lift grapple is designed so that its arms can follow a vertical wall and pick up logs even at the edges.



Available for L200H High Lift

Volvo high-lift grapple - Unloading against a wall					
Heart shaped	Area	Grapple width	Inner width	Maximum opening width	Weight
	m ²	mm	mm	mm	kg
Clamp arms	3.7	900	2 400	4 210	2 840

Volvo Log Pusher

Increase stack height by up to 30% (1.5 m) with the log pusher, an efficient tool for log handling operations which allows to push logs further onto the pile and store more timber.

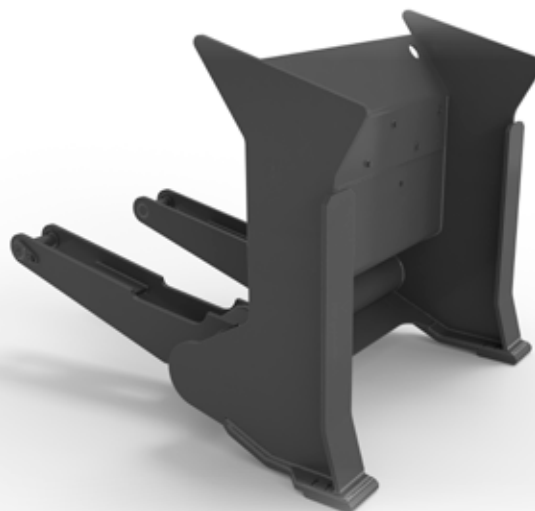

Operated by two push buttons, situated in front of the hydraulic control levers.



Available for L180H, L220H and L200H High Lift

Volvo Material Handling Arm

A useful tool to pick, carry or load a large variety of materials and equipment. The material handling arm can be the ideal choice when you need to efficiently move pipe, concrete blocks, highway dividers and more.



The material handling arm is built in three sections, with two telescopic sections.



Volvo Material Handling Arms

Length fully retracted	Length middle position	Length fully extended	Arm weight	Products								
				L60F/H	L70F/H	L90F/H	L110F/H	L120F/H	L150H	L180H	L220H	
3 270	4 300	5 440	380	x								
3 320	4 360	5 490	480		x							
3 270	4 410	5 540	500			x						
3 220	4 350	5 590	500				x					
3 290	4 430	5 560	500					x				
3 330	4 360	5 490	700						x			
3 420	4 450	5 580	700								x	
3 470	4 510	5 640	700									x





V O L V O