

Volvo Construction Equipment  
Building Tomorrow



# R100E

Volvo Rigid Haulers 95.0 t 1 065 hp



# WELCOME TO OUR WORLD

Welcome to a world of industry leading machinery. A world where imagination, hard work and technological innovation will lead the way towards developing a future which is cleaner, smarter, and more connected. A world supported by the enduring values of the Volvo Group. A world of stability, sustainability and innovation. A world which we put our customers at the heart of.

Welcome to the world of Volvo Construction Equipment – we think you're going to like it here.

## Working harder, working smarter

For over 180 years Volvo has been a pioneer in the design and manufacture of machines which set the standard for efficiency, performance and uptime. Across our range of excavators, wheel loaders and haulers, our reputation for engineering excellence is unrivalled, which means whatever your operation or application, we can provide a total fleet solution to help you succeed.

Building on our proud history, the Volvo Concept Lab continues to create cutting-edge ideas and innovative concepts, to ensure we offer customers machines which work harder and smarter long into the future.



## Solutions for you

Our industry leading machines are just the start of your relationship with Volvo. As your partner, we have developed an extensive range of additional solutions to help you improve uptime, boost productivity and reduce costs.

### Designed for your business

Structured across nine blocks, our portfolio of products and services are designed to complement your machine's performance and boost your profitability. Simply put, we offer some of the best guarantees, warranties and technological solutions in the industry today.

### There when you need us

Whether you're buying new or used, our global network of dealers and technicians offer around-the-clock support, including machine monitoring and world-class parts availability. It's the basis of everything offered by Volvo Services, so you can be confident we've got you covered right from the start.

**BUILDING TOMORROW**

# Drive your costs down

Drive your operating costs down with the all-new Volvo R100E. Built with highly efficient components, the rigid hauler offers long service intervals and component lifecycles. Get the most out of your investment with the fuel-efficient hauler, your partner for all mining and quarrying applications.

## Designed for distance

Save time and money with the R100E. The heavy-duty machine is engineered to extend service intervals, helping you cut maintenance costs and optimize uptime. Achieve unbeatable long-term value and longevity of major components with our reliable hauler.



## Long life, low costs

Component longevity is key to a low cost of operation. That's why your machine is rigorously tested under extreme working conditions to meet high component lifecycles industry standards. Do more in the long haul with the new E-Series rigid hauler promoting, as a standard, two retardation systems for high levels of safe performance, while safeguarding primary brake life.



## Heavyweight hauler

Go the extra mile with the optimally balanced R100E. Offering a low center of gravity and even weight distribution, the solid machine spreads the load impacts and structural stresses equally across the truck. The outcome is superb machine and tire longevity leading to significantly reduced operating costs. Leave it to Volvo to find the right balance.



## Volvo Dynamic Shift Control

Haul it all thanks to our fully automatic adaptive transmission gearshift patterns, further enhanced and payload sensitive if equipped with our On-Board Weighing option. Adapting to varying conditions, Volvo Dynamic Shift Control delivers productive performance through a smooth, consistent ride and low fuel consumption.



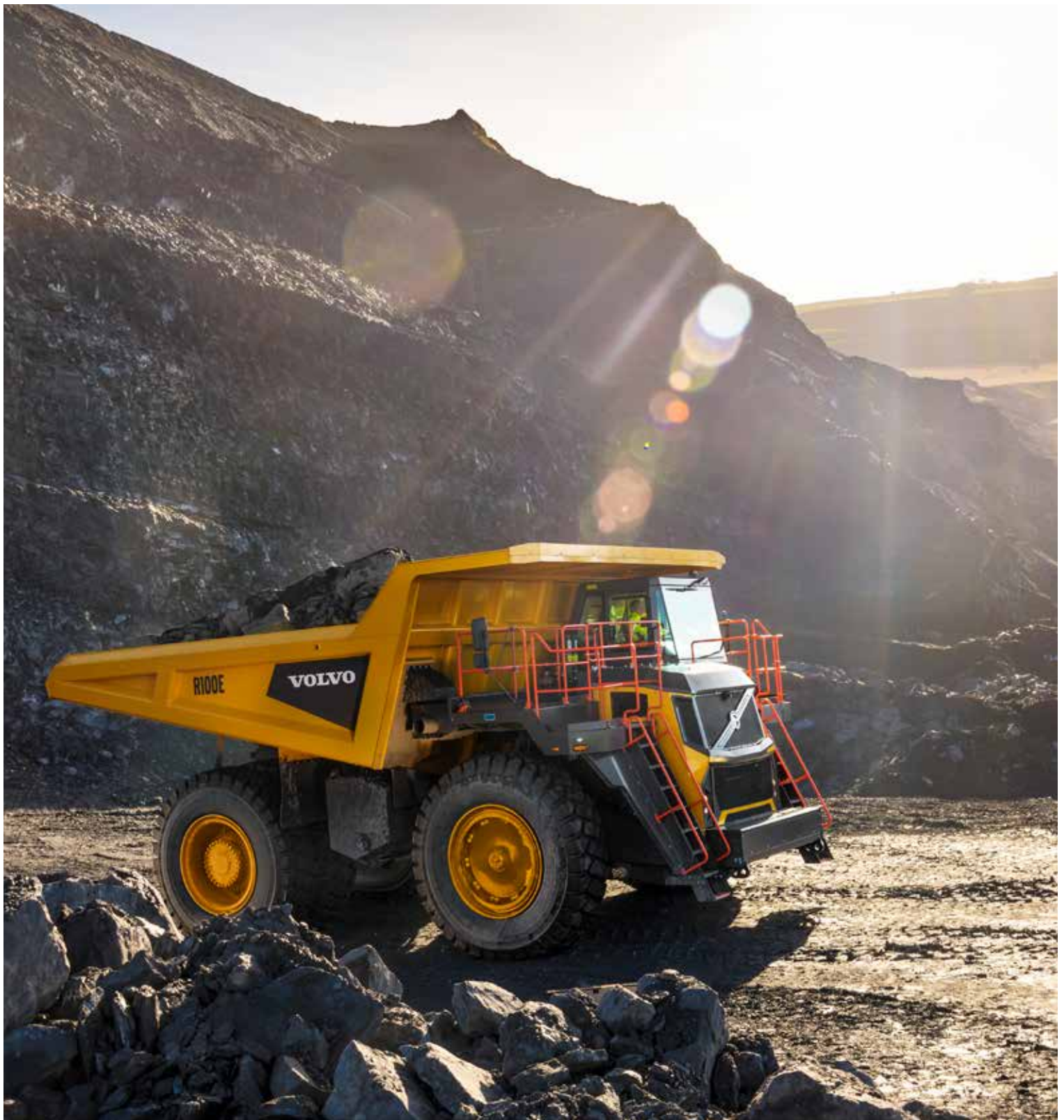

# E FOR EFFICIENCY

Move more with less fuel thanks to the latest technology built-into the R100E rigid hauler. The electronic integration between the engine and transmission achieve premium drivetrain performance, resulting in smooth gearshift quality and consistent machine momentum. Reduce your number one operating cost with Volvo.



# FULLY LOADED

Offering a true 95-tonne payload, the R100E is designed to do more. Thanks to its optional exhaust-heated V-shaped body, the 60.4 m<sup>3</sup> capacity hauler ensures optimum load retention and minimal material carry-back. For long lasting performance, the body is manufactured from high impact and high abrasion resistant steel. Enhance productivity with our 10-10-20 payload profile policy (please ask your local dealer for more detailed information).

# Move more, earn more

Meet production targets faster with the largest rigid hauler in the Volvo portfolio. Offering the winning combination of power and performance, the 95-tonne machine hauls more tonnes per hour. Move more and earn more with Volvo.

## Move more – faster

Get the job done with the R100E, powered by the premium engine. Delivering high torque capabilities, the combined drivetrain provides unparalleled pulling performance and class-leading rimpull for optimum travel time. Thanks to the fast body-tipping system, you can count on the R100E to achieve fast cycle times for an all-round efficient performance.



## Up to the challenge

No terrain is too deep or steep for the R100E. Thanks to the complete drivetrain design and configuration, the hauler yields impressive tractive effort, enabling you to tackle tough job site conditions and navigate gradients effortlessly. With high drive axle multiplication, the machine delivers high levels of rimpull for excellent performance on steep slopes.



## Real-time tonnage

Unlock the secret to your hauler's productivity using our optional On Board Weighing (OBW) technology from Volvo. The integrated system ensures the machine moves the optimum safe payload and logs all transported loads for complete production management, providing real-time data on the on-board display.



## Smart systems

Take your productivity to the next level thanks to smart systems – such as Volvo Site Simulation – for optimum site efficiency and minimal operational costs. To increase the productivity of your existing and future projects, utilize Volvo Site Simulation, which provides valuable information about your machinery, fleet choices and site configuration.



# Safety at the center

Safety is built into every design element of Volvo machines – and the R100E rigid hauler is no exception. Featuring a ROPS/FOPS-certified cab, proven safety systems and straightforward service access, the R100E is safe from the inside out.

## Solid stability

Featuring a low center of gravity, the rigid hauler is engineered to provide rock-solid stability. Conquer challenging conditions thanks to the expertly designed body and chassis, which work in harmony with the responsive suspension and steering geometry, for ultimate machine stability.



## Safety as standard

Rain or shine, know no limits with the Volvo R100E, promoting a transmission retarder as a standard. The proven feature provides excellent safe machine control in all downhill conditions, making it the ideal machine for all your mining and quarrying applications.



## Total access

Whether operating or servicing your R100E, gain safe and straightforward entry to the machine using anti-slip steps and secure walkways. From the wide platform or ground level, safely complete essential planned maintenance. For added protection and peace of mind – particularly during servicing – use integral safety locks to isolate the machine system.



## Always in control

Operate with complete confidence thanks to a host of safety systems, such as the transmission overspeed protection feature, engineered to automatically slow down the machine to within safe operating limits. Machine control is enhanced by the neutral coast inhibitor, which protects the hauler in downhill operations. For added security, the R100E features fail-safe braking and secondary steering systems.





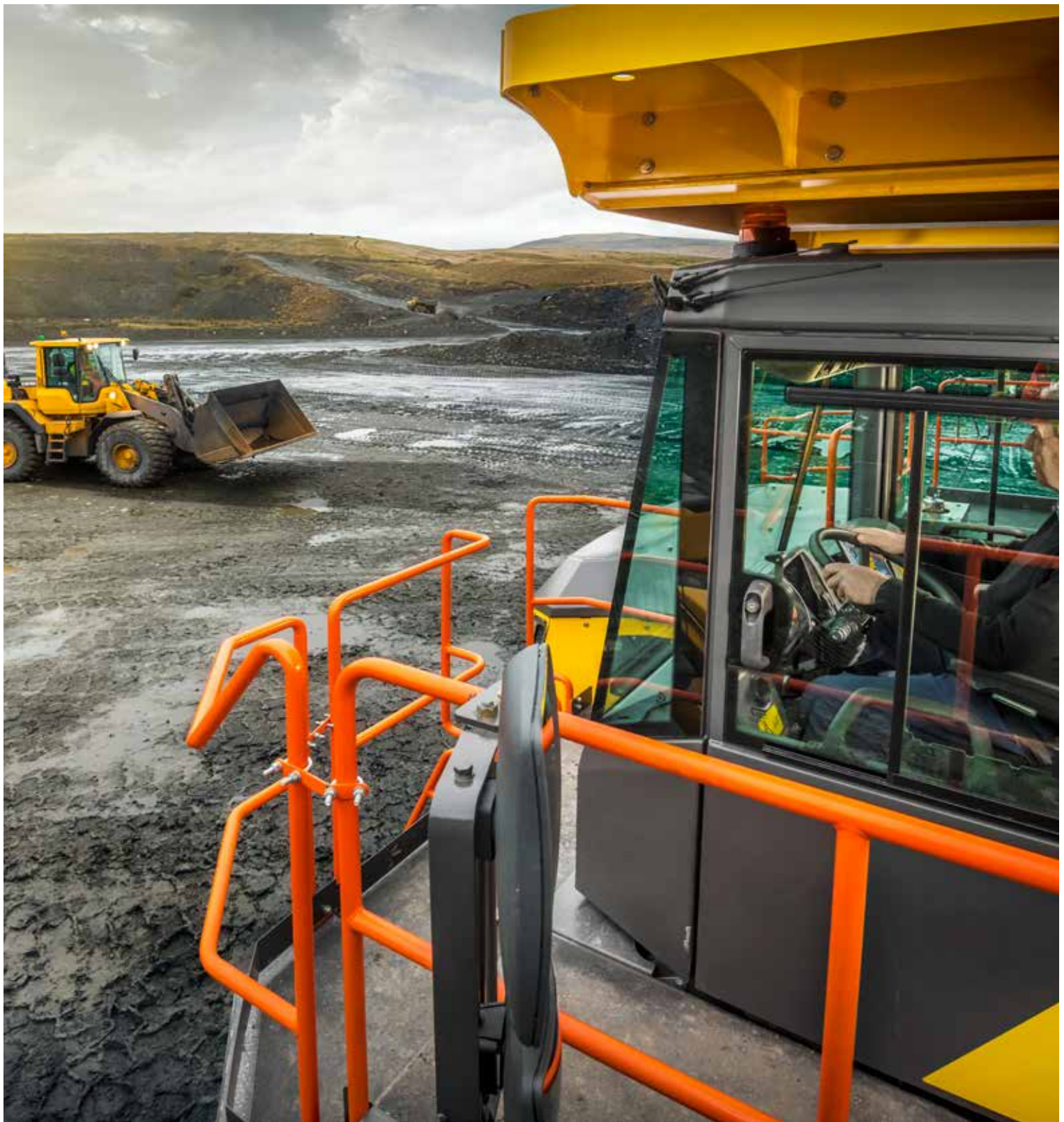

# SAFE FROM THE INSIDE OUT

There's no compromise when it comes to safety. That's why all machine systems on the R100E, such as the easily accessible emergency shutdown switches, have been designed and verified to protect the safety of you and your crew. From the ROPS/FOPS-certified cab, experience superb visibility, enhanced by Volvo Smart View, an integrated feature that helps you keep an eye on the surrounding job site traffic.



# BUILT READY

The robust and reliable R100E delivers superior, long lasting performance. Engineered with uptime in mind, the heavy-duty hauler is uncomplicated in its design, and purpose-built to achieve optimum productivity shift after shift, day in and day out.

# Access more uptime

Access more uptime with the R100E, designed to work for you. The machine design is purpose-built to meet the demands of tough job site conditions, including conveniently grouped service points for efficient maintenance tasks. Add a range of aftermarket solutions and the result is optimum machine availability.

## Ease of serviceability

Ease of access not only optimizes safety, but it also maximizes machine uptime. All service points are strategically grouped and within reach from the ground and service platform. To simplify mechanical servicing, the hauler features common-sized bearings and direct bolt-on wheel rim connections. Inside the cab, access top-level diagnostic data using the operator-friendly dashboard for fast analysis and solutions.



## Here to support you

The exclusive Volvo dealer network is here to support you whenever you need it. Volvo offers a number of services, local knowledge and global mining experience, including superb parts availability. Speak to your local Volvo dealer for more information about uptime-enhancing solutions, such as Volvo Services Agreements (VSA) and extended warranties.



## Durable by design

Built to last, the R100E is durable by design. The high strength, flexible chassis structure and responsive MacPherson strut with lower wishbone connection absorb potentially damaging shocks and vibrations that can occur when operating. Regardless of environmental conditions, you can depend on the hydraulics to remain clean and protected against contamination for optimum machine availability.

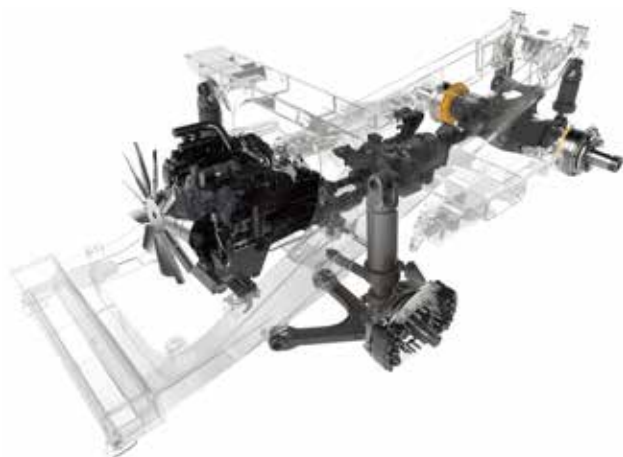

## Robust protection

Working in challenging conditions means every component must be protected. With the Volvo R100E, you can rely on a strong design and excellent build quality. Ensure long component lifecycle and machine uptime thanks to the latest generation transmission control system, neutral coast inhibitor and overspeed protection features.



# Operator's choice

Not only a highly efficient machine, the R100E also brings operator productivity to the fore – starting with comfort and control. Offering 360° visibility, responsive steering, ergonomic controls, low noise and solid stability, the Volvo cab is as good as it gets.

## Every angle in view

Take on the tough stuff from the comfort of the industry-leading cab, boasting an impressive 360° bird's eye view of the work zone thanks to Volvo Smart View. The operator seat is located to the left side of the cab, enabling you to observe all surrounding areas. Forward visibility is enhanced thanks to the large windscreen, offering excellent line of sight.



## Tailor-made to meet your needs

Customize your comfort for increased productivity throughout the working day. The Volvo air suspension operator seat and tiltable, telescopic steering wheel can be fully adjusted to match your preferred operating position. With the standard Bluetooth enabled audio system, you can stay connected.



## Comfortably productive

Get comfortable with doing more in the pressurized Volvo cab, offering all-around visibility, climate control, and ample storage and legroom. From the adjustable operator seat, easily access displays and responsive fingertip controls, ergonomically positioned to keep the focus on the operation.



## Low noise, high comfort

Stay focused in the Volvo cab, offering remarkably low noise levels. Built-in sound insulation eliminates distracting noises, while the viscous isolated mounted cab and hydraulic suspension system minimizes ground vibrations and surrounding job site noise. Because a happy, comfortable operator enhances overall productivity and performance.



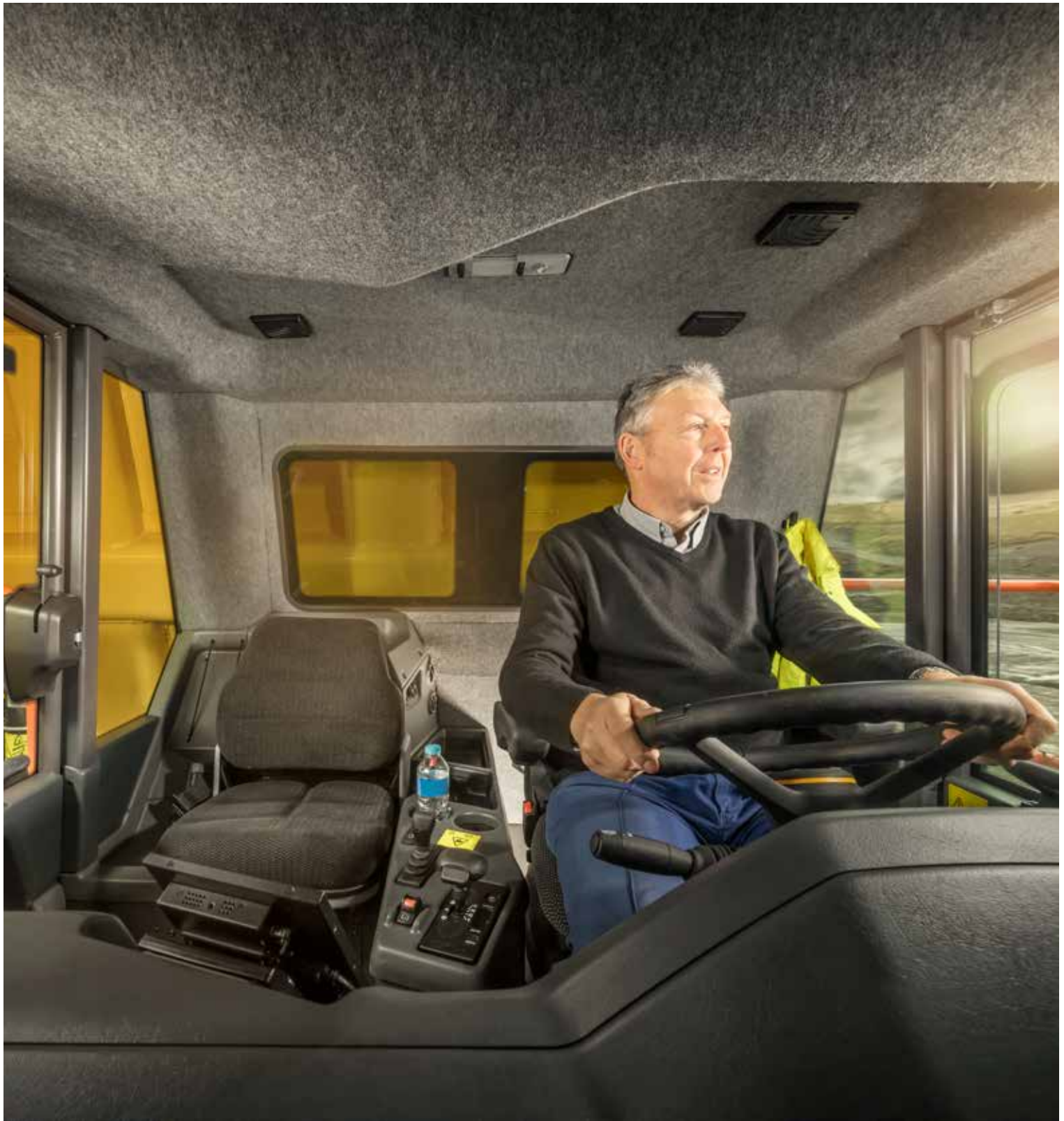

# SMOOTH OPERATION

Enjoy superior ride quality and comfort in the robust R100E, equipped with responsive MacPherson strut with lower wishbone connection and viscous-mounted cab for minimal ground impact and vibrations. The responsive, low-effort steering system and geometry, combined with the suspension, optimizes maneuverability by minimizing lean on tight corners. With the R100E, heavy-duty hauling has never felt so easy.

# Haul it all

## Comfortably productive

The pressurized cab offers superb visibility, climate control, ample space, as well as ergonomic displays and fingertip controls.

## E FOR EFFICIENCY

Reduce your number one operating cost thanks to the latest technology built into the R100E rigid hauler.

## Robust protection

Ensure long component lifecycle with the transmission control system, neutral coast inhibitor and overspeed protection.

## Long life, low costs

The R100E offers a standard transmission retarder, promoting extended service brake life, safety and performance.

## BUILT READY

Achieve long lasting performance and uptime thanks to the simple and uncomplicated machine design.

## Volvo Dynamic Shift Control

Haul it all thanks to fully automatic adaptive transmission gearshift patterns, payload sensitive if equipped with On-Board Weighing.





## SAFE FROM THE INSIDE OUT

Protect you and your crew with the ROPS/FOPS Volvo cab, featuring easily accessible emergency brake switches and Volvo Smart View.

## FULLY LOADED

Offering a true 95-tonne payload, the optional exhaust-heated V-shaped body optimizes load retention and minimizes material carry-back.

### Real-time tonnage

Unlock the secret to your hauler's productivity with the OBW system, designed to ensure you shift the optimum safe payload.

### Up to the challenge

Navigate gradients with ease thanks to superb tractive efforts offered by the complete drivetrain design and configuration.

### Designed for distance

Do more in the long haul with the R100E, offering long component lifecycles and extended service intervals.

## SMOOTH OPERATION

Enjoy superior ride quality and comfort thanks to minimal ground impact and vibrations, and easy maneuverability.

# Specifications

## R100E

Payload capacity	kg	95 000
Body Volume, SAE 2:1 heap	m <sup>3</sup>	60.4
Net weight	kg	69 550
Gross weight	kg	164 550
Engine		Cummins QST30 CAC
Engine emission		Tier 2 / Stage II
Max. engine gross power	kW	783
... at engine speed	r/min	2 100
Max. SAE J1349 gross torque	Nm	4 631
... at engine speed	r/min	1 300
Max. speed	km/h	50

Not all products are available in all markets. Under our policy of continuous improvement, we reserve the right to change specifications and design without prior notice. The illustrations do not necessarily show the standard version of the machine.



**VOLVO**

**Volvo Construction Equipment**

[volvoce.com](http://volvoce.com)