



Volvo Construction Equipment

PL3005E, PL4809E

Volvo Pipelayers Tipping capacity PL3005E: 55 t / 120,000 lb | PL4809E: 96-110 t / 212,000-242,000 lb



A passion for performance

At Volvo Construction Equipment, we're not just coming along for the ride. Developing products and services that raise productivity – we are confident we can lower costs and increase profits for industry experts. Part of the Volvo Group, we are passionate about innovative solutions to help you work smarter – not harder.

Helping you to do more

Doing more with less is a trademark of Volvo Construction Equipment. High productivity has long been married to low energy consumption, ease of use and durability. When it comes to lowering life-cycle costs, Volvo is in a class of its own.

Designed to fit your needs

There is a lot riding on creating solutions that are suited to the particular needs of different industry applications. Innovation often involves high technology – but it doesn't always have to. Some of our best ideas have been simple, based on a clear and deep understanding of our customers' working lives.



You learn a lot in 180 years

Over the years, Volvo has advanced solutions that have revolutionized the use of construction equipment. No other name speaks Safety louder than Volvo. Protecting operators, those around them and minimizing our environmental impact are traditional values that continue to shape our product design philosophy.

We're on your side

We back the Volvo brand with the best people. Volvo is truly a global enterprise, one that is on standby to support customers quickly and efficiently – wherever they are.

We have a passion for performance.



Volvo Trucks



Renault Trucks



Mack Trucks



UD Trucks



Volvo Buses



Volvo Construction Equipment



Volvo Penta



Volvo Financial Services

The multi-tasker

Do everything traditional side-booms can, and so much more with the E-series Volvo pipelayers. As well as lowering in, you can take advantage of infinite placement possibilities utilizing the unique 360° swing capacity, coupled with the stability to work safely up to a 35° slope. The class-leading excavator-based design enables superior capacities, and maximum return on investment thanks to its versatility to take on many jobs.

Best for productivity and stability

Handle large, heavy pipes with ease with the highly productive E-series Volvo pipelayers. Offering superior capacities coupled with a unique design, they are the most stable and safe pipelayers in their class for working on slopes. The PL4809E is classified with up to 110 tonne tipping capacity.



Industry-leading safety

Increase operator productivity with the industry-leading, spacious and comfortable cab. The ROPS-safety certified cab provides ergonomically positioned controls, and excellent vibration and noise insulation. The hydraulic cab riser system offers excellent visibility both into the trench and around the worksite. The controls are based on the excavator cab layout meaning you can pick from a large pool of operators.

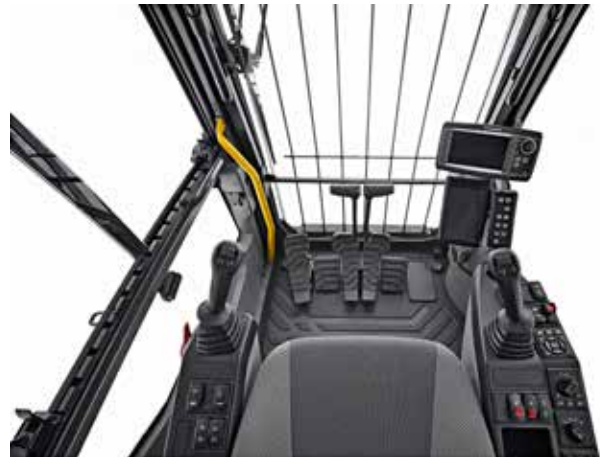

Maximizing return on investment

Get the most out of your investment by utilizing the versatility of the excavator-based rotating Volvo pipelayer. The machines can be easily converted from the pipelayer to a standard excavator in just half a day and used with any excavator attachment.



The all-rounder

Take on many applications with one machine thanks to its 360° swing, including loading/offloading, tie-ins, and feeding pipe-bending machines. The 360° swing enables you to work all around the machine in a stationary position, so you can avoid moving the tracks and damaging the ground, as well as increase safety on the jobsite.





INFINITE PLACEMENT POSSIBILITIES

Achieve maximum manoeuvrability and performance from the E-series Volvo pipelayers, utilizing their unique 360° swing capacity. Offering infinite pipe placement possibilities, the excavator-based design of the pipelayer enables working safely up to a 35° slope. Rely on a safe operation with the Load Management System (LMS), which signals when the load limit is reached as well as indicating its load status to others on site.



TIME IS MONEY - GET TO WORK FAST

Maximize uptime with the revolutionary E-series Volvo pipelayers. Enabling you to move around the jobsite with ease, the machine can be moved within 30 minutes without having to disassemble the boom and counterweight. Get straight to work with this versatile, time-saving design.

Every minute counts

The E-series Volvo pipelayers have been designed with maximum uptime in mind. You can get back to work in no time when moving the machine between and around jobsites as you never need to disassemble the boom and the counterweight. Volvo is committed to providing tailored solutions to guarantee the highest performance from your machine wherever in the world you are, and whenever you need it, with state-of-the-art support through our global support network.

Cost-effective maintenance

Maximize uptime with regular cleaning and servicing of the remote filters, which are easily accessed separately from the engine and radiator. Keep costs down by avoiding unscheduled downtime and ensuring detailed monitoring of your machine with CareTrack. Remotely receive reports on the machine location, usage, productivity, fuel consumption and more.



The highest quality at every part

Retain the highest quality machine with every part. Optimized for maximum uptime and performance of your machine, Genuine Volvo Parts are extensively tested and approved to ensure the highest quality. Benefit from reduced stocking costs for wear and maintenance parts as up to 90% of the recommended stock order for the Volvo pipelayers are common with the excavators'.



Here to support you

Rely on support when you need it, where you need it; even in the most remote locations. Take advantage of an extensive infrastructure of technicians, workshops and dealers in the global Volvo service network. Specialist support sites can be set up in connection with Volvo dealers for customers in remote locations. By listening to your requirements, Volvo can tailor solutions to reduce your total cost of ownership.



Enhanced training

Utilize a safer, more efficient mode of training with the world's first pipelayer simulator from Volvo. Enhance training value with the highly sophisticated and realistic simulator, ensuring a more productive operation. Operators can be trained not only on the basics of machine operation for both pipelayer and excavator, but also for uncommon situations without risking the safety of anyone on the jobsite.



Ensuring load safety

The Load Management System (LMS) indicates the load status and signals when the load limit has been reached.

Industry-leading safety

Increase operator productivity and safety with the ROPS-safety certified cab and standard Load Management System.

INFINITE PLACEMENT POSSIBILITIES

Achieve infinite pipe placement possibilities with the 360° swing capacity and stability up to a 35° slope.

The highest quality at every part

Genuine Volvo Parts are extensively tested and approved to ensure the highest quality.

Maximizing return on investment

Utilize the versatility of the Volvo pipelayer which can be converted to a standard excavator in just half a day or less.

Cost-effective maintenance

Maximize uptime with easy-to-access service points and by tracking your machine remotely via CareTrack.



360° solution

TIME IS MONEY – GET TO WORK FAST

Move around and between jobsites with ease without having to disassemble the boom and counterweight.

Best for productivity and stability

Handle large, heavy pipes with the most stable and safe pipelayers in their class in all conditions, even on slopes.

Enhanced training

Utilize a safer, more efficient mode of training with the world's first pipelayer simulator from Volvo.

Reduce part stocking costs

Up to 90% of the Volvo pipelayers' recommended stock order for wear and maintenance parts are common with excavators'.

Here to support you

Rely on support when you need it, where you need it, with the comprehensive, global Volvo service network.

The all-rounder

Take on many applications with one machine in a stationary position thanks to its 360° swing.



Volvo PL3005E, PL4809E in detail

Engine

The latest generation, Volvo engine Tier 4f (Stage IV) emissions compliant diesel engine fully meets the demands of the latest, emissions regulations. Featuring Volvo Advanced Combustion Technology (V-ACT), it is designed to deliver superior performance and fuel efficiency. The engine uses precise, high-pressure fuel injectors, turbo charger and air-to-air intercooler, and electronic engine controls to optimize machine performance. Air Filter: 3-stage with pre-cleaner. Automatic Idling System: Reduces engine speed to idle when the levers and pedals are not activated resulting in less fuel consumption and low cab noise levels.

PL3005E

Engine	Volvo	D8J
Max power at	r/min (r/s)	1 800 (30)
Net, ISO 9249 / SAE J1349	kW / hp metric (hp)	179 / 243 (240)
Gross, ISO 14396 / SAE J1995	kW / hp metric (hp)	180 / 245 (241)
Max torque	Nm (ft lbf)	1 238 (913)
at engine speed	r/min (r/s)	1 350 (22.5)
No. of cylinders		6
Displacement	l (in ³)	7.8 (476)
Bore	mm (in)	110 (4.3)
Stroke	mm (in)	136 (5.4)

PL4809E

Engine	Volvo	D13J
Max power at	r/min (r/s)	1 800 (30)
Net, ISO 9249 / SAE J1349	kW / hp metric (hp)	283 / 385 (380)
Gross, ISO 14396 / SAE J1995	kW / hp metric (hp)	284 / 386 (381)
Max torque	Nm (ft lbf)	1 928 (1,422)
at engine speed	r/min (r/s)	1 350 (22.5)
No. of cylinders		6
Displacement	l (in ³)	12.8 (781)
Bore	mm (in)	131 (5.16)
Stroke	mm (in)	158 (6.22)

Electrical System

High-capacity electrical system that is well protected. Waterproof double-lock harness plugs are used to secure corrosion-free connections. The main relays and solenoid valves are shielded to prevent damage. The master switch is standard. Contronics provides advanced monitoring of machine functions and important diagnostic information.

Voltage	V	24
Batteries	V	2 x 12
Battery capacity	Ah	200
Alternator	V/Ah	28/80

Track Drive System

PL3005E: Each track is powered by user adjustable travel motor. The track brakes are multi-disc, spring-applied and hydraulically released. The travel motor, brake and planetary gears are well protected within the track frame.

PL4809E: Each track is powered by an automatic shift two speed travel motor. Track brakes are multi-disc, spring applied and hydraulically released. Travel motors, brakes and planetary final drives are well protected within the track frame. *PL4809E has user adjustable variable speed motors

Travel System

PL3005E

Max. travel speed	km/h (mi/h)	5.5 (3.4)
-------------------	-------------	-----------

PL4809E

Max. travel speed	km/h (mi/h)	6 (3.7)
-------------------	-------------	---------

Undercarriage

PL3005E:

The undercarriage has a robust X-shaped frame. Greased and sealed track chains are standard.

PL4809E:

The hydraulically variable gauge system provides a wide gauge for working stability which can be retracted for reduced transport width. Removable track frame mounted counterweights provide added stability and lower the machine center of gravity – they are easily removed to reduce transport weight.

Hydraulic System

The hydraulic system is designed for high productivity, high lifting capabilities, high maneuvering precision and superb fuel economy.

PL3005E

Main pump, type 2 x variable displacement axial piston pumps		
Maximum flow	l/min (gal/min)	2 x 263 (2 x 69.5)
Pilot pump, type gear pump		
Maximum flow	l/min (gal/min)	18 (5)

PL4809E

Main pump, type 2 x variable displacement axial piston pumps		
Maximum flow	l/min (gal/min)	2 x 358 (2 x 94.6)
Pilot pump, type gear pump		
Maximum flow	l/min (gal/min)	32 (8.45)

Hydraulic Motors

PL3005E:

Travel: Variable displacement axial piston motor with mechanical brake
Swing: Fixed displacement piston motor with mechanical brake
Winch: Fixed displacement piston motor with mechanical brake

PL4809E:

Travel: Variable displacement axial piston motor with mechanical brake
Swing: Fixed displacement axial piston motor with mechanical brake

Cab

The Volvo Care Cab, with operator protective structure, provides safety along with more interior, leg and foot space. In work mode, the cab is hydraulically elevated by 496mm / 19.5" providing a wide field of vision to the entire job site, winch, boom and load block. Through the cab glass, transparent roof hatch and two-piece sliding door window, visibility is maximized. This improves operator confidence, comfort, safety and effectiveness. The deluxe seat features adjustable height, tilt, recline and forward-back settings as well as a retractable seat belt and selectable horizontal suspension which cushions the operator from vibrations

Boom

The asymmetric boom gives the operator a clear view to the hook block at all heights as well as into the trench for safe, precise load placement. The long boom provides high hook height and reach allowing the machine to work further from the trench.

Winch

Planetary, high line pull winch delivers smooth lifting performance and precise control. The winch hydraulic motor has a multi-disc friction brake which is spring applied and hydraulically released.

Load Management System

Operator confidence, effectiveness and safety are enhanced with Volvo's Load Management System. Volvo pipelayers utilize load, boom and superstructure-mounted sensors that allow onboard computers to monitor boom angle as well as cab orientation and inclination. The computer uses this information to compute and display actual loads and rated working loads in real-time through an in-cab monitor with audible warning systems. This allows the operator to maintain full control of the machine both on flat and level ground as well as on steep slopes throughout the 360 degree swing. The Load Management System utilizes boom-mounted load indicator lights for visual communication with ground staff and between adjacent machines during multiple lift operations.

Transportability

The E-series Volvo pipelayers can easily be transported without the need to disassemble boom or counter weights.

Specifications

OPERATING WEIGHT AND GROUND PRESSURE (WITH STANDARD BOOM)

Track shoe width		with STANDARD COUNTERWEIGHT		Ground pressure		with ADDITIONAL REAR COUNTERWEIGHT		Ground pressure	
mm	in	kg	lb	kPa	psi	kg	lb	kPa	psi
PL3005E									
600	24"	35 030	77,230	66.3	9.6	-	-	-	-
750	30"	35 720	78,750	54.1	7.8	-	-	-	-
800	32"	35 990	79,340	51.1	7.4	-	-	-	-
PL4809E									
700	28"	58 606	129,230	88.1	12.8	62 106	136,940	93.3	13.5
750	30"	58 685	129,400	82.3	11.9	62 185	137,120	87.2	12.6
900	36"	59 630	131,480	69.7	10.1	63 130	139,200	73.8	10.7

OPERATING WEIGHT AND GROUND PRESSURE (WITH EXTENDED BOOM)

Track shoe width		with STANDARD COUNTERWEIGHT		Ground pressure		with ADDITIONAL REAR COUNTERWEIGHT		Ground pressure	
mm	in	kg	lb	kPa	psi	kg	lb	kPa	psi
PL3005E									
600	24"	36 060	79,500	68.2	9.9	-	-	-	-
750	30"	36 750	81,020	55.6	8.1	-	-	-	-
800	32"	37 020	81,620	52.5	7.6	-	-	-	-
PL4809E									
700	28"	60 076	132,470	90.3	13.1	63 576	140,190	95.6	13.8
750	30"	60 155	132,640	84.4	12.2	63 655	140,360	89.3	12.9
900	36"	61 100	134,730	71.4	10.4	64 600	142,440	75.5	10.9

OTHER WEIGHTS

		PL3005E		PL4809E	
		kg	lb	kg	lb
1	Boom with winch (with rope stored)	-	-	7 064	15,580
	Boom	2 740	6,050	-	-
2	Boom cylinder (dry)	600	1,320	1 425	3,140
3	Adaptor with winch (with rope stored)	2 460	5,390	-	-
	Adaptor	-	-	2 985	6,580
4	Hook block	245	540	520	1,150
5	Flag block	370	820	484	1,070
6	Boom extension	1 030	2,270	1 470	3,240
7	Counterweight, rear	6 900	15,210	8 700	19,180
8	Extra counterweight	-	-	3 500	7,720
9	Counterweight, Track frame	-	-	2 X 902	2 X 1,990
10	Boom assembly (1-5)	6 405	14,120	12 478	27,510
	with boom extension (1-6)	7 435	16,390	13 948	30,760
11	Standard equipped machine (minus 1-5)	28 625	63,110	-	-
	Standard equipped machine (minus 1-5 & 7 & 9)	-	-	35 703	78,730

WORKING RANGE PL3005E

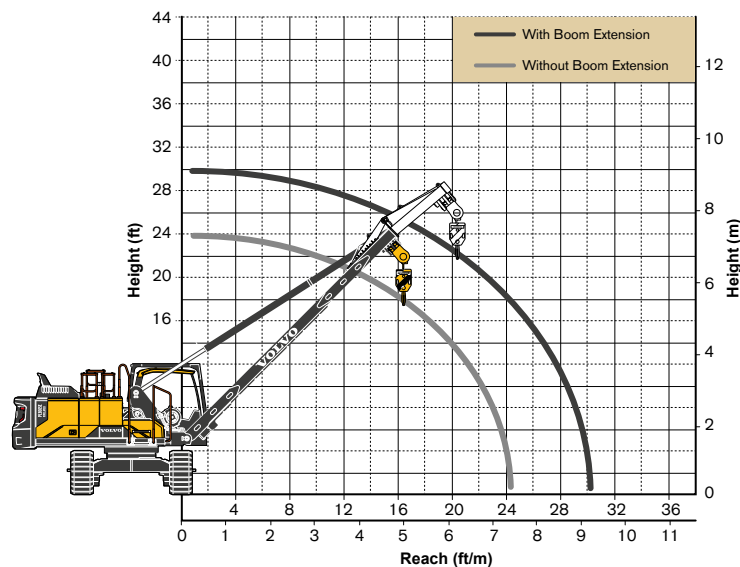

Footnotes PL3005E

Max tipping capacity per ISO 8813, Rated capacity per ASME B30.14, lift capacity valid through 360 degree rotation				
Boom length (std)	m	ft in	7.4	24' 4"
Boom length with Extension	m	ft in	9.2	30' 4"
Rear counterweight	kg	lb	6 900	15,210
Track frame counterweights	kg	lb	-	-
Wire rope diameter	mm	in	16	5/8"
with minimum breaking strength of	kg	lb	20 600	45,400
Reeving on load block	Parts			6

Specifications

LOAD CHARTS WITH STANDARD CONFIGURATION PL3005E

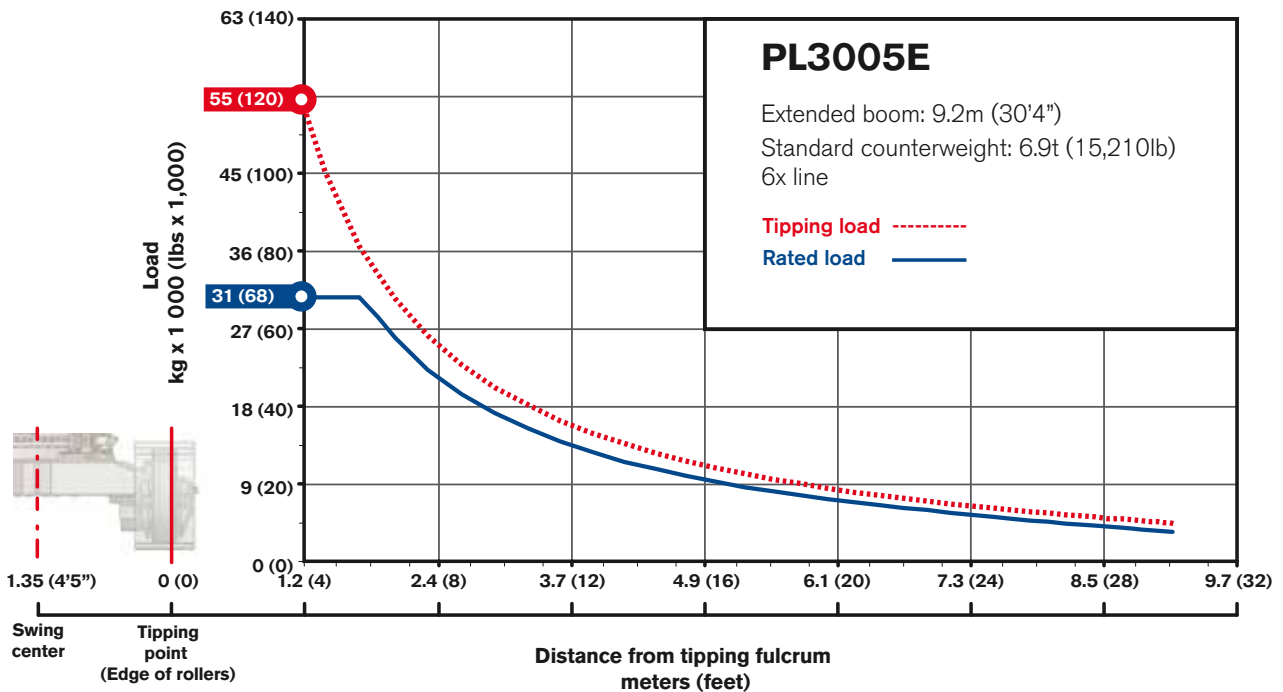
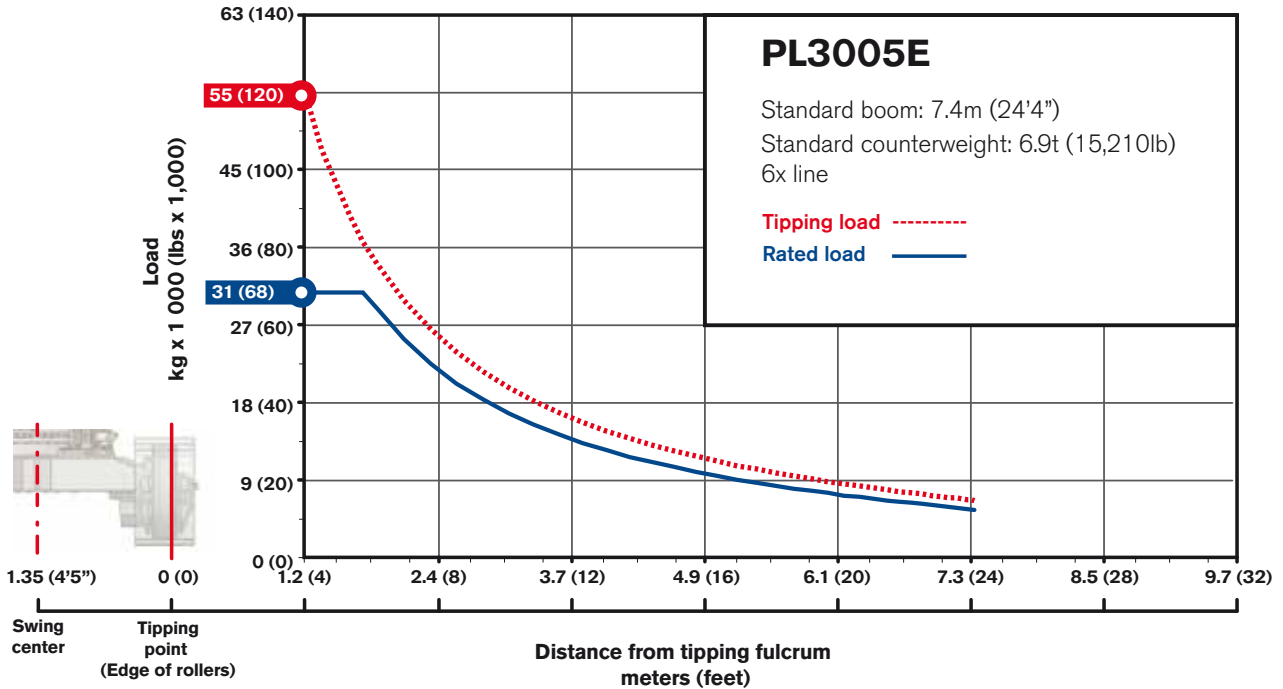

Note: Max tipping capacity per ISO 8813, SAE J743, and ASME B30.14. Rated capacity per ISO 8813 and ASME B30.14, lift capacity valid through 360 degree rotation.

WORKING RANGE PL4809E

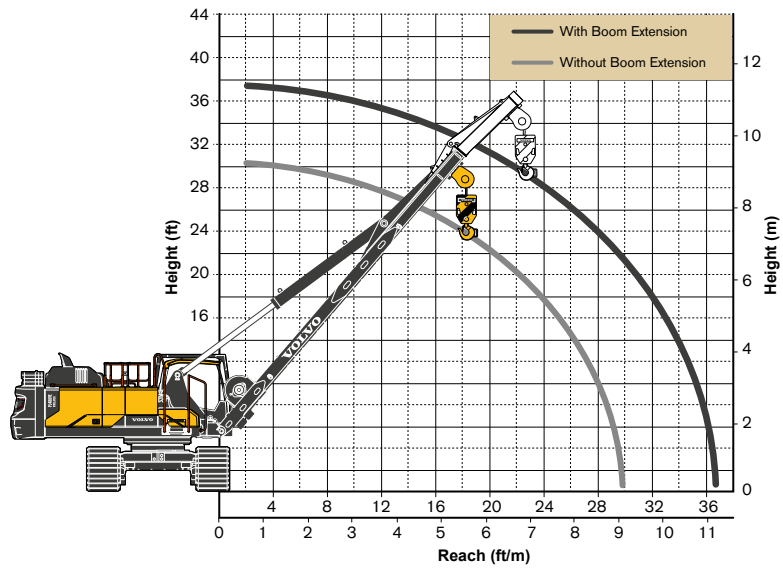

Footnotes PL4809E

Max tipping capacity per ISO 8813, Rated capacity per ASME B30.14, lift capacity valid through 360 degree rotation					
Boom length (std)	m	ft in	9.2		30' 4"
Boom length with Extension	m	ft in	11.2		36' 11"
Rear counterweight	kg	lb	8 700		19,180
Rear counterweight with additional CWT	kg	lb	12 200		26,900
Track frame counterweights	kg	lb	2 X 902		2 X 1,989
Wire rope diameter	mm	in	22		7/8"
with minimum breaking strength of	kg	lb	36 000		79,400
Reeving on load block		Parts			6

Specifications

LOAD CHARTS WITH STANDARD CONFIGURATION PL4809E

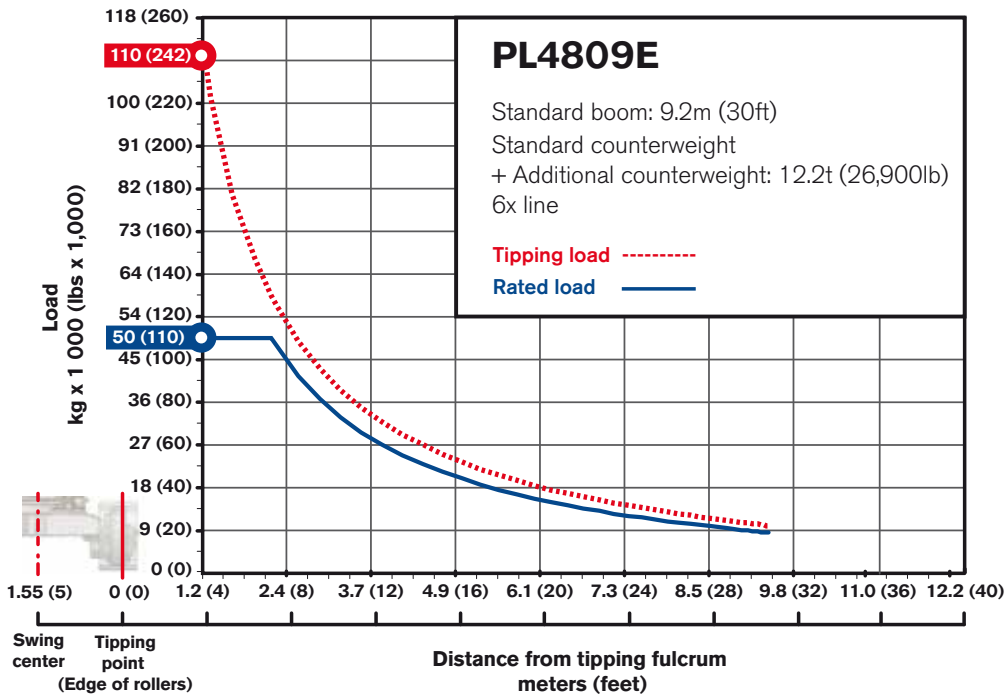
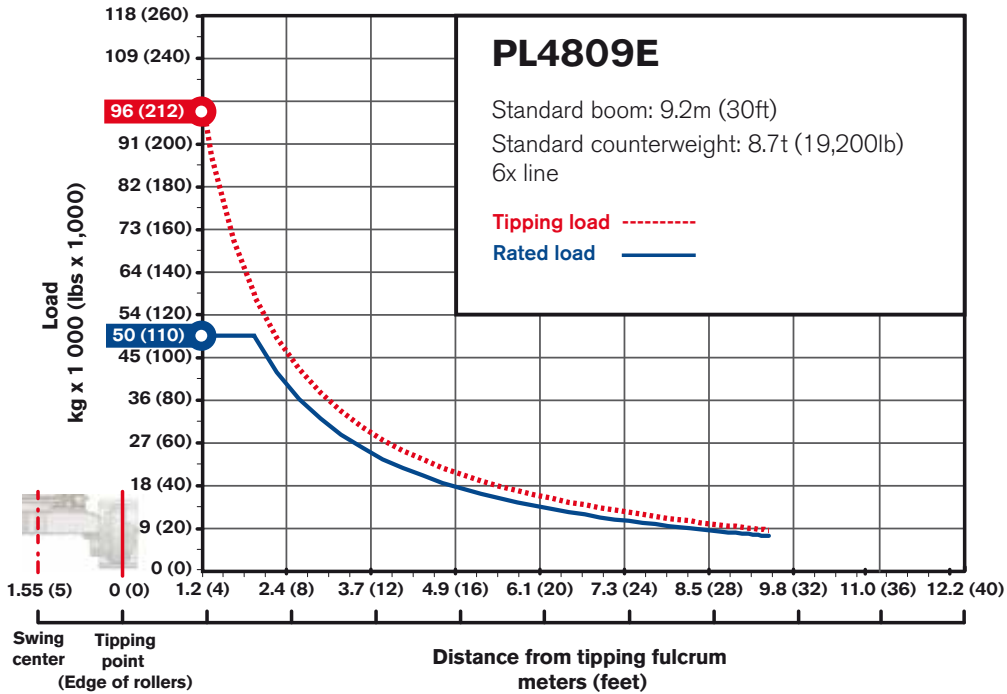

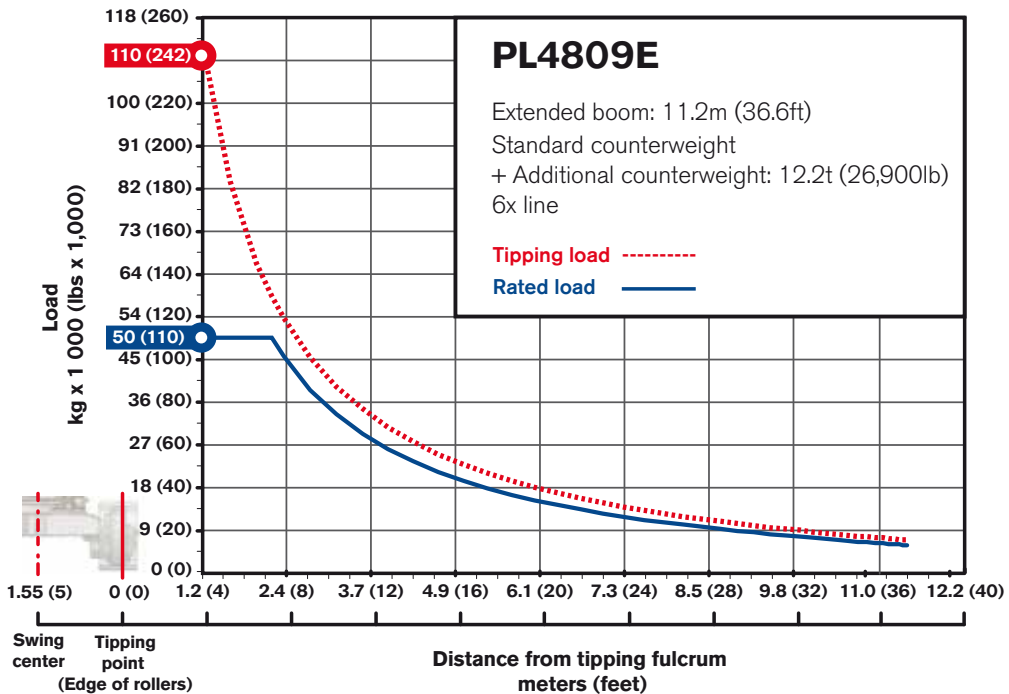
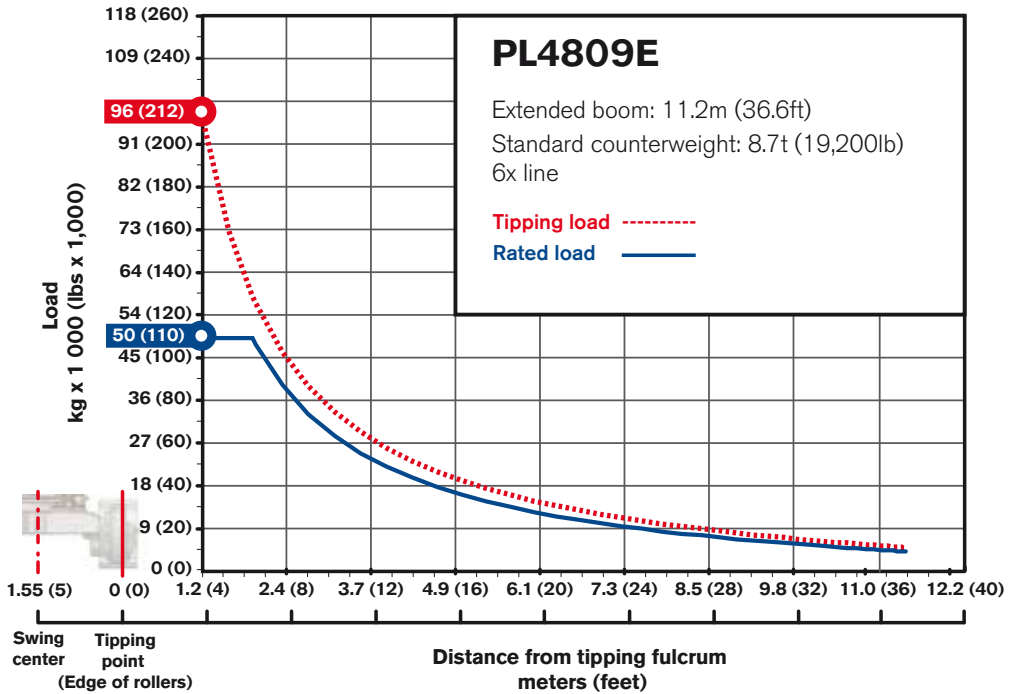

Note: Max tipping capacity per ISO 8813, SAE J743, and ASME B30.14. Rated capacity per ISO 8813 and ASME B30.14, lift capacity valid through 360 degree rotation.

Specifications

DIMENSIONS

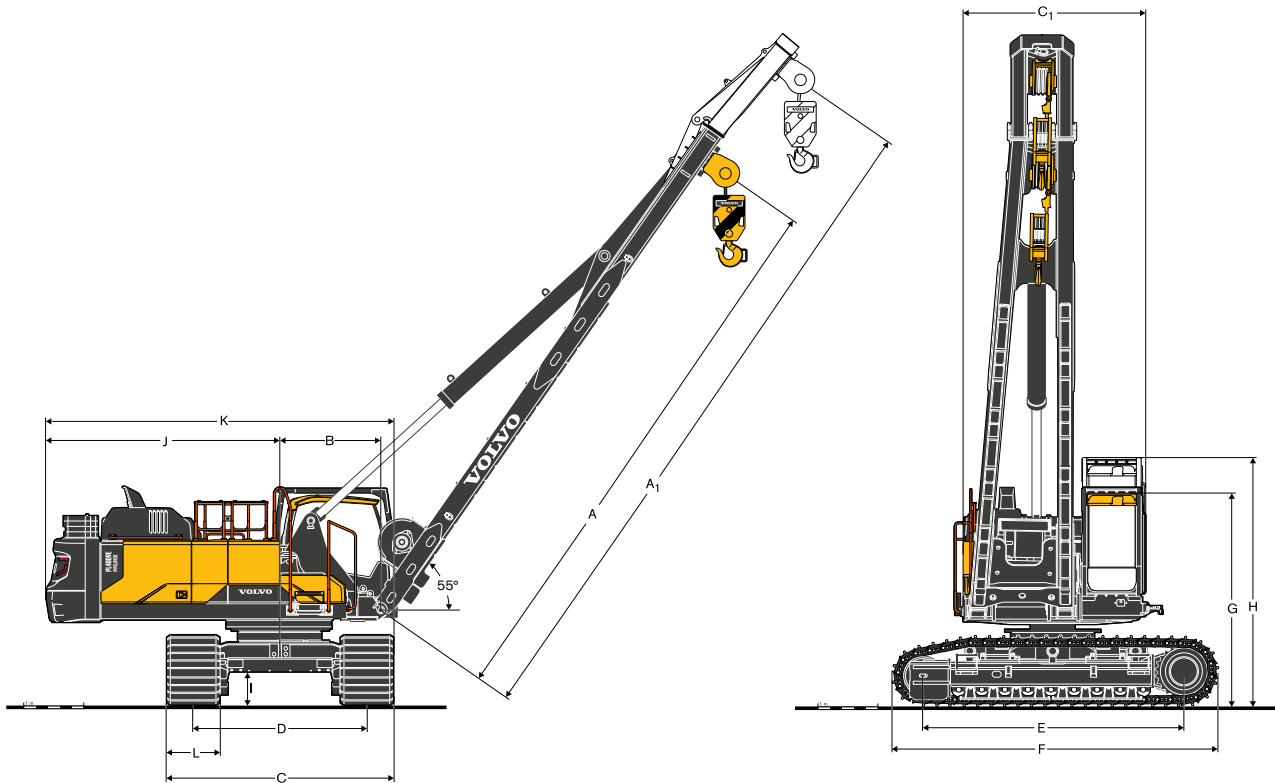

Description		Unit		PL3005E		PL4809E	
A	Boom length	mm	ft in	7 430	24' 4"	9 250	30' 4"
A ₁	Boom length (boom extension)	mm	ft in	9 240	30' 4"	11 250	36' 11"
B	Swing center - boom mount pin	mm	ft in	1 470	4' 10"	1 680	5' 6"
C	Overall width (600mm; 24" shoes)	mm	ft in	3 190	10' 6"	-	-
	Overall width (750mm; 30" shoes, tracks extended)	mm	ft in	-	-	3 640	11' 11"
	Overall width (750mm; 30" shoes, tracks retracted)	mm	ft in	-	-	3 140	10' 4"
C ₁	Overall width upper structure; bolted items removed (handrail, steps, catwalk)	mm	ft in	2 930	9' 7"	3 030	9' 11"
D	Track gauge (PL4809D Extended)	mm	ft in	2 590	8' 6"	2 890	9' 6"
	Track gauge (PL4809D Retracted)	mm	ft in	-	-	2 390	7' 10"
E	Tumbler length	mm	ft in	3 970	13'	4 370	14' 4"
F	Track length	mm	ft in	5 030	16' 6"	5 530	18' 2"
G	Overall height, Cab in lower position with ROPS	mm	ft in	3 450	11' 3"	3 680	12' 1"
H	Overall height, Cab in upper position with ROPS	mm	ft in	3 940	12' 11"	4 180	13' 9"
I	Minimum ground clearance	mm	ft in	580	1' 11"	600	2' 0"
J	Tail swing radius	mm	ft in	3 120	10' 3"	3 880	12' 9"
K	Maximum base machine width, across undercarriage (with 600mm; 24" shoes)	mm	ft in	4 710	15' 6"	-	-
	Maximum base machine width, across undercarriage (with 750mm; 30" shoes)	mm	ft in	-	-	5 700	18' 8"
L	Track shoe	mm	ft in	600	24"	700	28"
	Track shoe	mm	ft in	750	30"	750	30"
	Track shoe	mm	ft in	800	32"	900	36"
	Track shoe	mm	ft in	-	-	1 050	42"

Dimensions base machine

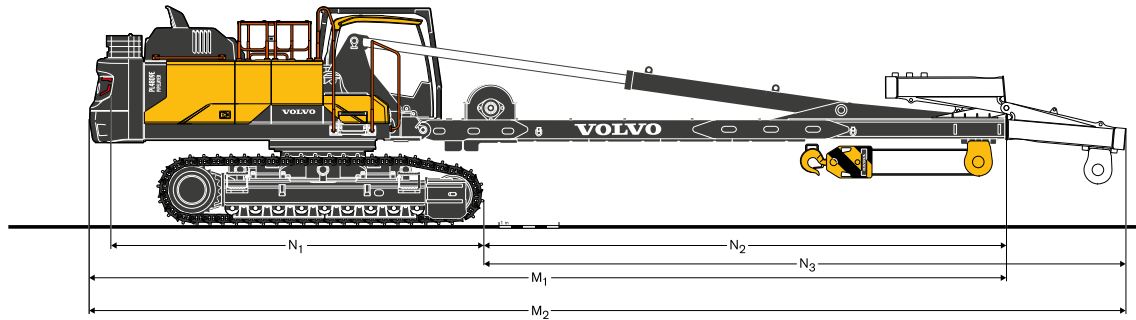

Dimensions component modules

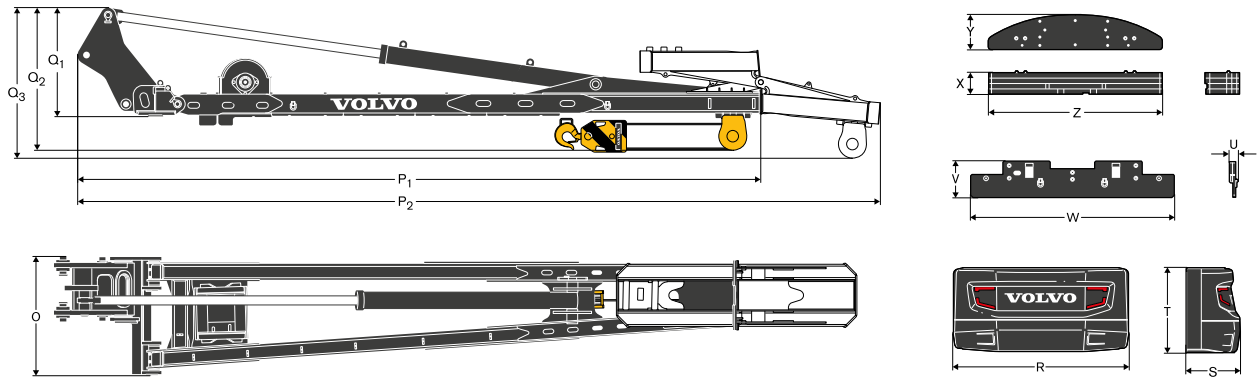

Description	Unit	PL3005E		PL4809E	
M ₁ Total transport length (boom extension stored/off)	mm ft in	12 260	40' 3"	15 260	50' 1"
M ₂ Total transport length (boom extension extended)	mm ft in	14 140	46' 5"	17 250	56' 7"
N ₁ Counterweight bracket - front of track	mm ft in	5 410	17' 9"	6 240	20' 5"
N ₂ Front of track to end of boom (boom extension stored/off)	mm ft in	6 640	21' 10"	8 690	28' 6"
N ₃ Front of track to end of boom (boom extension extended)	mm ft in	8 520	27' 11"	10 680	35'
O Width boom assembly	mm ft in	1 580	5' 2"	1 960	6' 5"
P ₁ Length boom assembly (boom extension stored/off)	mm ft in	9 190	30' 2"	11 360	37' 3"
P ₂ Length boom assembly (boom extension extended)	mm ft in	11 070	36' 4"	13 350	43' 10"
Q ₁ Height boom assembly (excluding flag block)	mm ft in	1 710	5' 8"	1 960	6' 5"
Q ₂ Height boom assembly (boom extension stored/off)	mm ft in	2 190	7' 2"	2 380	7' 10"
Q ₃ Height boom assembly (boom extension extended)	mm ft in	2 370	7' 9"	2 510	8' 3"
R Width rear counterweight	mm ft in	2 990	9' 6"	2 990	9' 10"
S Length rear counterweight	mm ft in	600	2'	890	2' 11"
T Height rear counterweight	mm ft in	1 360	4' 5"	1 430	4' 8"
U Thickness track frame counterweight	mm ft in	-	-	140	6"
V Height track frame counterweight	mm ft in	-	-	590	1' 11"
W Width track frame counterweight	mm ft in	-	-	3 330	10' 11"
X Thickness additional rear counterweight	mm ft in	-	-	370	1' 2"
Y Length additional rear counterweight	mm ft in	-	-	590	1' 11"
Z Width additional rear counterweight	mm ft in	-	-	2 950	9' 8"

Overall transport width

PL3005E

Track shoe width		Machine width	
mm	ft in	mm	ft in
600	24"	3 190	10'6"
750	30"	3 340	10'11"
800	32"	3 390	11'1"

PL4809E

Track shoe width		Machine width retracted		Machine width extended	
mm	ft in	mm	ft in	mm	ft in
700	28"	3 090	10'2"	3 590	11'9"
750	30"	3 140	10'4"	3 640	11'11"
900	36"	3 290	10'10"	3 790	12'5"
1 050	42"	-	-	3 940	12'11"

Equipment

STANDARD EQUIPMENT	PL3005E	PL4809E
Engine		
Turbocharged, 4 stroke diesel engine with water cooling, direct injection and charged air cooler that meets Tier 4f EU (Stage IV) requirements	•	•
Air filter with indicator	•	•
Air intake heater	•	•
Electric engine shut-off	•	•
Fuel filter and water separator	•	•
Cyclone pre-cleaner	•	•
Alternator, 80 A	•	•
Electric / Electronic control system		
Anti-two block device	•	•
Advanced mode control system	•	•
Self-diagnostic system	•	•
Machine status indication	•	•
Engine speed sensing power control	•	•
Automatic idling system	•	•
One-touch power boost	•	•
Safety stop/start function	•	•
Load management system (LMS)	•	•
Adjustable 8 inch LCD color monitor	•	•
Master electrical disconnect switch	•	•
Engine restart prevention circuit	•	•
High-capacity halogen work light (1 cabin deck mounted):	•	•
Travel alarm	•	•
Batteries, 2 x 12 V / 200 Ah	•	•
Start motor, 24 V / 5.5 kW (PL3005E)	•	—
Start motor, 24 V / 7 kW (PL4809E)	—	•
Frame		
Access way with handrail	•	•
Counterweight 6 900 kg / 15,210 lb	•	—
Hydraulically removable counterweight 8 700 kg / 19,180lb	—	•
Tool storage area	•	•
Service walkway with anti-slip grating	•	•
Undercover	•	•
Undercarriage		
Hydraulic track adjusters	•	•
Greased and sealed track link	•	•
Hydraulically retractable track frame	—	•
Full track guard	•	•
Undercover	•	•
Tow Lugs	•	•
Track frame counterweights 2 x 902kg / 2 x 1,989lb	—	•
Hydraulic system		
Hydraulic system digging kit ready	•	•
Separate and combined pump flow switch	•	•
360 degree slew with hydro-mechanical slew lock system	•	•
Swing anti-rebound valves	•	•
Multi-stage filtering system	•	•
Boom cylinder	•	•
Auxiliary hydraulic valve	•	•
Automatic two-speed travel motors	•	—
User Adjustable Variable speed travel motors	—	•
Long life hydraulic oil, ISO VG 46	•	•

STANDARD EQUIPMENT	PL3005E	PL4809E
Cab and interior		
4 Bar cab riser	•	•
Fabric seat with heater and air suspension	•	•
Control joystick with proportional control	—	•
Travel pedals with hand levers	•	•
Straight travel pedal	•	•
Heater & air-conditioner, automatic	•	•
Adjustable operator seat and joystick control console	•	•
Switchable winch control joystick	•	•
Hydraulic safety lock lever	•	•
AM/FM stereo with MP3, USB, and bluetooth input:	•	•
Cab, all-weather sound suppressed, includes:	•	•
Cup holders	•	•
Door locks	•	•
Floor mat	•	•
Horn	•	•
Large storage area	•	•
Pull-up type front window	•	•
Removable lower windshield	•	•
Seat belt 3"	•	•
Safety glass	•	•
Windshield wipers with washer and intermittent feature (Front and right hand side)	•	•
Anti-vandalism kit assembly preparation	•	•
Master key	•	•
Fixed hatch	•	•
Rear and side view camera	•	•
Four-bar cab riser-mounted, ROPS certified (ISO 3471 & EN474-1), factory installation only 4 bar cab riser-mounted	•	•
Track shoes		
600mm / 24" Track shoes, single grouzers	•	—
750mm / 30" Track shoes, single grouzers	—	•
Pipelayer booms		
Prepared for boom extension	•	•
7.4m / 24' 4"	•	—
9.2m / 30' 4"	—	•
Winch	•	•
Flag block	•	•
Hook block	•	•
Wire rope, D16	•	—
Wire rope, D22	—	•
Service		
Tool kit, daily maintenance	•	•

OPTIONAL EQUIPMENT		
	PL3005E	PL4809E
Engine		
Block heater: 240V	•	•
Block heater: 120V, 240V	•	•
Diesel coolant heater, 10 kW,	•	•
Water separator with heater	•	•
Fuel filler pump: 50 l/min, with automatic shut-off	•	•
Oil bath pre-cleaner	•	•
Electric		
Extra lamps:	•	•
Cab-front only (Halogen) 2	•	•
Cab-mounted (Halogen) 2 front, 1 rear	•	•
Counterweight-mounted (Halogen) 1	•	•
Boom lights for PL Boom (LED) 4	•	•
Anti-theft system	•	•
Rotating warning beacon: Halogen or LED	•	•
Superstructure		
Additional counterweight, 3 500kg / 7,710lb	—	•
Hydraulic system		
Hammer & shear 2 pump flow & Slope & rotator & Quick coupler	•	•
Long life hydraulic oil, ISO VG 32	•	•
Long life hydraulic oil, ISO VG 68	•	•
Hydraulic oil, biodegradable 46	•	•

OPTIONAL EQUIPMENT		
	PL3005E	PL4809E
Cab and interior		
Smoker Kit (Ashtray and lighter)	•	•
Sun shield	•	•
Track shoes		
750mm / 30"	•	—
900mm / 36"	—	•
700mm / 28"	—	•
800mm / 32"	•	—
900mm / 36"	—	•
Pipelay booms		
Boom extension: 1.8m / 6'	•	—
Boom extension: 2m / 6'7"	—	•
Boom pads	•	•
Pipe Carrying and Protection	•	•
Digging Equipment		
Boom 6.2m / 20'4", arm 3.05m / 10'0" with aux hydraulic (Hose rupture valve, hammer & shear piping, quick coupler piping, slope rotator piping)	•	—
Boom 7.0m / 23'0", arm 3.35m / 11'0" with aux hydraulic (Hose rupture valve, hammer & shear piping, quick coupler piping, slope rotator piping)	—	•
Other		
Artic option package for digging equipment	—	•
Artic option package for pipelayer equipment	—	•

SELECTION OF VOLVO OPTIONAL EQUIPMENT

Boom extension



Pipe support



Digging kit



Boom lights



Track shoe options



Not all products are available in all markets. Under our policy of continuous improvement, we reserve the right to change specifications and design without prior notice. The illustrations do not necessarily show the standard version of the machine.

VOLVO

Volvo Construction Equipment

www.volvoce.com