



# EW200E MATERIAL HANDLER

Volvo Material Handler 22.1-22.8 tons



# WELCOME TO OUR WORLD

Welcome to a world of industry leading machinery. A world where imagination, hard work and technological innovation will lead the way towards developing a future which is cleaner, smarter, and more connected. A world supported by the enduring values of the Volvo Group. A world of stability, sustainability and innovation. A world which we put our customers at the heart of.

Welcome to the world of Volvo Construction Equipment – we think you're going to like it here.

## Working harder, working smarter

For over 180 years Volvo has been a pioneer in the design and manufacture of machines which set the standard for efficiency, performance and uptime. Across our range of excavators, wheel loaders and haulers, our reputation for engineering excellence is unrivalled, which means whatever your operation or application, we can provide a total fleet solution to help you succeed.

Building on our proud history, the Volvo Concept Lab continues to create cutting-edge ideas and innovative concepts, to ensure we offer customers machines which work harder and smarter long into the future.





# Solutions for you

Our industry leading machines are just the start of your relationship with Volvo. As your partner, we have developed an extensive range of additional solutions to help you improve uptime, boost productivity and reduce costs.

### Designed for your business

Structured across nine blocks, our portfolio of products and services are designed to complement your machine's performance and boost your profitability. Simply put, we offer some of the best guarantees, warranties and technological solutions in the industry today.

### There when you need us

Whether you're buying new or used, our global network of dealers and technicians offer around-the-clock support, including machine monitoring and world-class parts availability. It's the basis of everything offered by Volvo Services, so you can be confident we've got you covered right from the start.

**BUILDING TOMORROW**

# Volvo EW200E MATERIAL HANDLER in detail

## Engine

Manufacturer	Volvo		
Model	D6J		
Output	kW	129	
	hp	173	
Exhaust emission	EPA Tier 4 final / EU Stage V		

## Operating weight

Straight boom 5.5m with 3.5m sorting arm , FOPS Solideal Twin Tyres 10.00-20, outriggers front & rear Kinshofer D S60 D20 H P 100 (450l/1 135kg)	kg	22 850	
Straight boom, 5.5 with 4 m goose neck arm, FOPS Solideal twin tyres 10.00-20, Blade Front & Outriggers Rear Kinshofer OP-GR P22V-450-5-W grapple(450l/1 046kg)	kg	22 100	



## Specifications

Boom	Goose neck arm	Reach	Name
5.5 m	4	9 330	EW200E MH G9
6.25 m	4	10 060	EW200E MH G10

Boom	Sorting arm	Reach	Name
5.5 m	3.5	9 020	EW200E MH S9



EW200E MH G9



EW200E MH G10



EW200E MH S9

**EW200E MH G9**

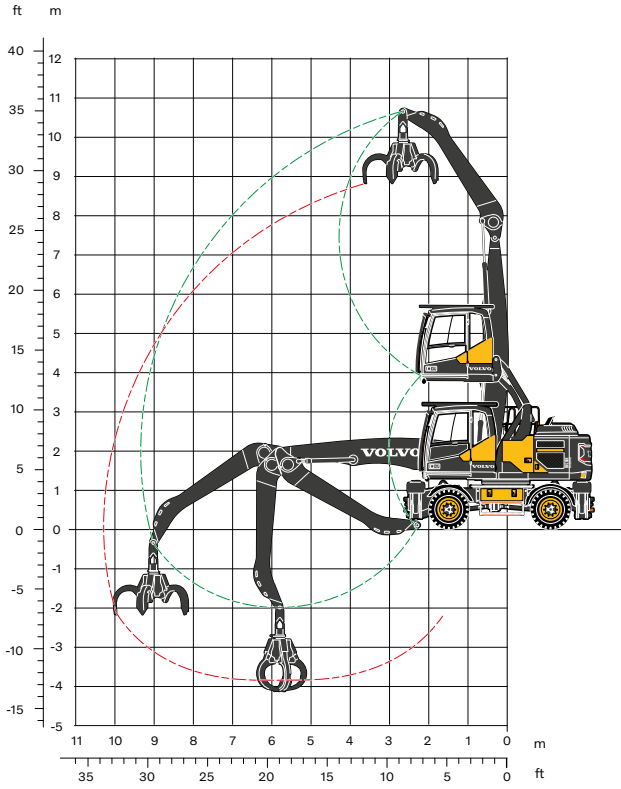

**EW200E MH G10**

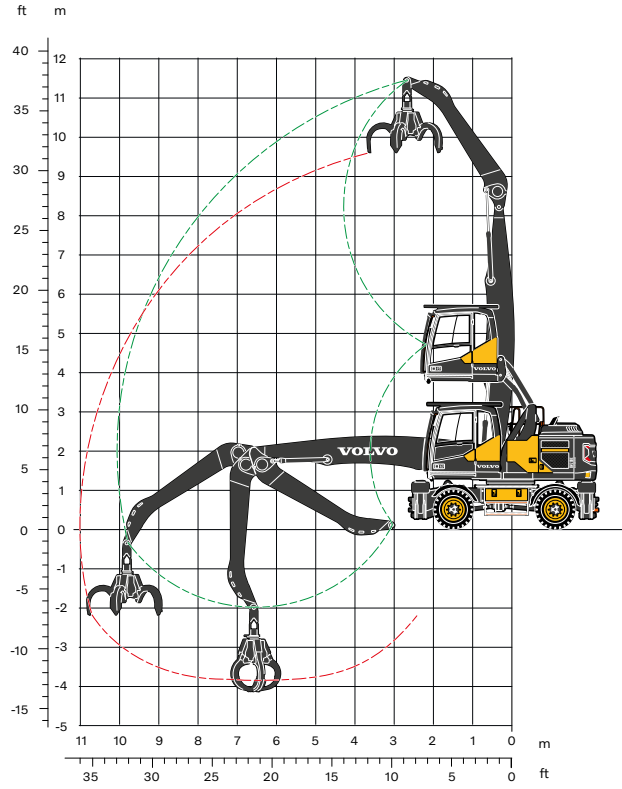

**EW200E MH S9**

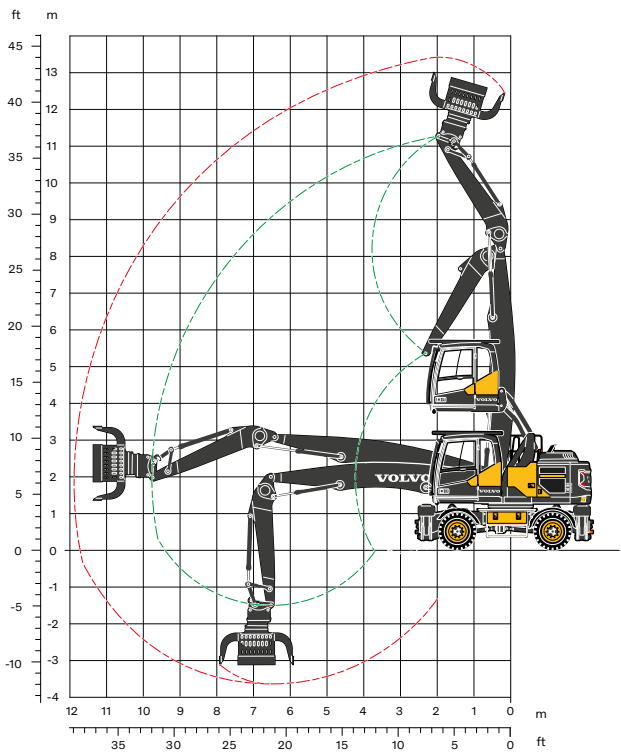



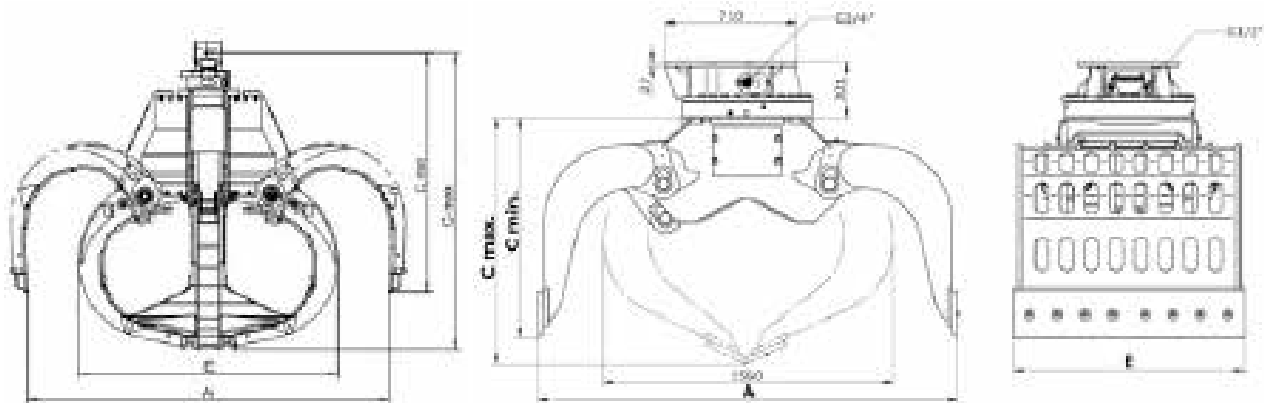

#### Attachments

MOM Description	Width E (mm)	Opening A (mm)	Height C (mm)	Volume (liter)	Weight (kg)	Capacity (kg)	Closing force (kN)
Kinshofer Sort Gr Df D20-H-P-100	1000	1890	1400	450	1120	5 000	43
Kinshofer Sort Gr S60 D20-H-P-100							
MOM Description	Width E (mm)	Opening A (mm)	Height C (mm)	Volume (liter)	Weight (kg)	Capacity (kg)	Number of tines
Kinshofer Op-Gr P22v-450-5-W	1370	1910	1545	450	970	7 000	5

Not all products are available in all markets. Under our policy of continuous improvement, we reserve the right to change specifications and design without prior notice. The illustrations do not necessarily show the standard version of the machine.

**VOLVO**

**Volvo Construction Equipment**

[volvoce.com](http://volvoce.com)