

V O L V O



Volvo Compact Excavators 1.88-2.12 t 16.3 hp

**EC20E**

Volvo Construction Equipment

# EC20E



# Compact versatility

## Small machine, big performance



- 13% increase in traction force
- 3 120 kg combined digging forces
- Improved lifting capacity by an average of 22% to the front and 7% to the side

## Small but tough



- All-around steel panels **NEW**
- High-profile cast counterweight **A VOLVO EXCLUSIVE**
- Protected hoses, routed inside the boom
- In-track boom swing

## Safety first



- High visibility entry step and cab handrail, orange seatbelt **A VOLVO EXCLUSIVE**
- 4 large easily accessible tie-down points on the upper frame **NEW**
- Controls lock options (switch, seat operator presence or buckled seatbelt sensor) **A VOLVO EXCLUSIVE**
- Easy entrance-exit to cab

## The operator's choice



- Easy front window opening with lower window removal and storage ability **NEW**
- Fingertip controls, with adjustable hydraulic flow **A VOLVO EXCLUSIVE**
- Simple controls layout
- Automatic 2-speed travel
- Smooth combined movements

## Versatile performance



- Secondary accessory circuit **A VOLVO EXCLUSIVE**
- Double acting circuit for hydraulic quick coupler **NEW**
- Variable undercarriage, under 1-meter wide

## The complete package



- Range of Volvo buckets and quick couplers
- Matched Volvo breaker
- Genuine Volvo Parts
- Volvo Financial Services

## Maximize profitability



- Convenient access to engine compartment thanks to hinged fuel tank **A VOLVO EXCLUSIVE**
- Auto engine shutdown and auto-idle (options) **A VOLVO EXCLUSIVE**
- All-around flat windows
- 50-hour greasing intervals
- Patented hydraulic filter

# Volvo EC20E in detail

Engine		
Engine		D0.9A
Max. power at	r/min	2 300
Gross	kW	12
	hp	16.3
According to ISO 2534 / SAE J1995		
Max. torque	Nm	52
at engine speed	r/min	1 800
No. of cylinders		3
Displacement	cm <sup>3</sup>	898
Bore	mm	72
Stroke	mm	73.6
Compression ratio		24
Electrical System		
Voltage	V	12
Battery	V	1 x 12
Battery capacity	Ah	70
Alternator	V/Ah	12/40
Swing system		
Max, slew speed	r/min	9.5
Max, slew torque	daNm	345
Undercarriage		
Bottom/top rollers per side		3 / 0
Track tension	By grease piston	
Blade (width x height)	mm	1 340 x 241
Digging Performances		
Standard bucket width (blade, W/O side cutter)	mm	500
Standard bucket mass	kg	48
Standard bucket rated capacity	l	63
Bucket rotation	°	199
Bucket breakout force (ISO)	daN	1 827
Short arm tearout force (ISO)	daN	1 229
Long arm tearout force (ISO)	daN	1 033

Weight and Ground Pressure		
Operating weight according to ISO 6016	kg	1 965
Ground pressure (cab)	kPa	30.4
Transport weight	kg	1 890
With rubber tracks	mm	230
With short arm	mm	1 050
With fuel tank capacity	%	100
With canopy	-kg	84
With long arm	+kg	10
Hydraulic System		
Pump type		Piston pump
Maximum system flow	l/min	48
Maximum flow for accessories	l/min	43
Maximum flow for 2nd accessory circuit (option)	l/min	23
Maximum operating pressure	MPa	21
Travel System		
Max, drawbar pull	daN	1 620
Max. travel speed low	km/h	2.5
Max. travel speed high	km/h	4.6
Gradeability	°	30
Service Refill		
Fuel tank	l	21
Hydraulic system, total	l	21
Hydraulic tank	l	15
Sound Level		
Interior sound level according to ISO 6396		
L <sub>pA</sub>	dB	78
External sound level according to ISO 6395 and EU Noise Directive (2000/14/EC) and 474-1:2006 +A1:200		
L <sub>WA</sub>	dB	93

## LIFTING CAPACITY EC20E

These capacities are given for a machine equipped with a cabin, rubber tracks and without a bucket or quick coupler. The below values are in compliance with ISO standard 10567. They do not exceed 75% of the tipping load or 87% of the hydraulic limit with the machine on firm level ground. Loads marked with an asterisk (\*) are limited by machine's hydraulic lifting capacity rather than tipping load. Caution: In accordance with EN 474-5, the machine must be equipped to carry out handling operations. It is the operator's obligation to know and follow the applicable national and local safety regulations.

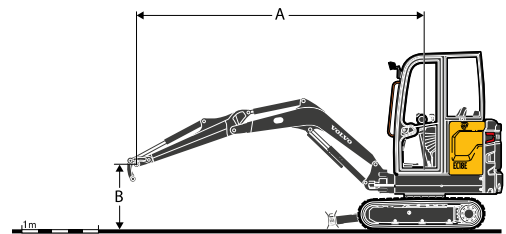

	Lifting point height (B) m		Lifting point radius (A)						Max. m
			2.0 m		3.0 m		Max reach		
Arm: 1 050mm + Dozer blade up	2	kg	-	-	365	352	320	310	3.25
	1	kg	641	608	351	338	281	272	3.48
	0	kg	609	577	339	327	291	281	3.35
	-1	kg	613	580	-	-	379	365	2.79
Arm: 1 050mm + Dozer blade down	2	kg	-	-	396*	352	404*	310	3.25
	1	kg	774*	608	474*	338	429*	272	3.48
	0	kg	964*	577	540*	327	465*	281	3.35
	-1	kg	850*	580	-	-	511*	365	2.79
Arm: 1 350mm + Dozer blade up	2	kg	-	-	333*	333*	279	270	3.55
	1	kg	647*	618	352	339	248	240	3.76
	0	kg	604	572	335	323	254	246	3.64
	-1	kg	599	567	333	320	313	301	3.15
Arm: 1 350mm + Dozer blade down	2	kg	-	-	333*	333*	353*	270	3.55
	1	kg	647*	618	426*	339	377*	240	3.76
	0	kg	928*	572	519*	323	412*	246	3.64
	-1	kg	907*	567	501*	320	457*	301	3.15

# Specifications

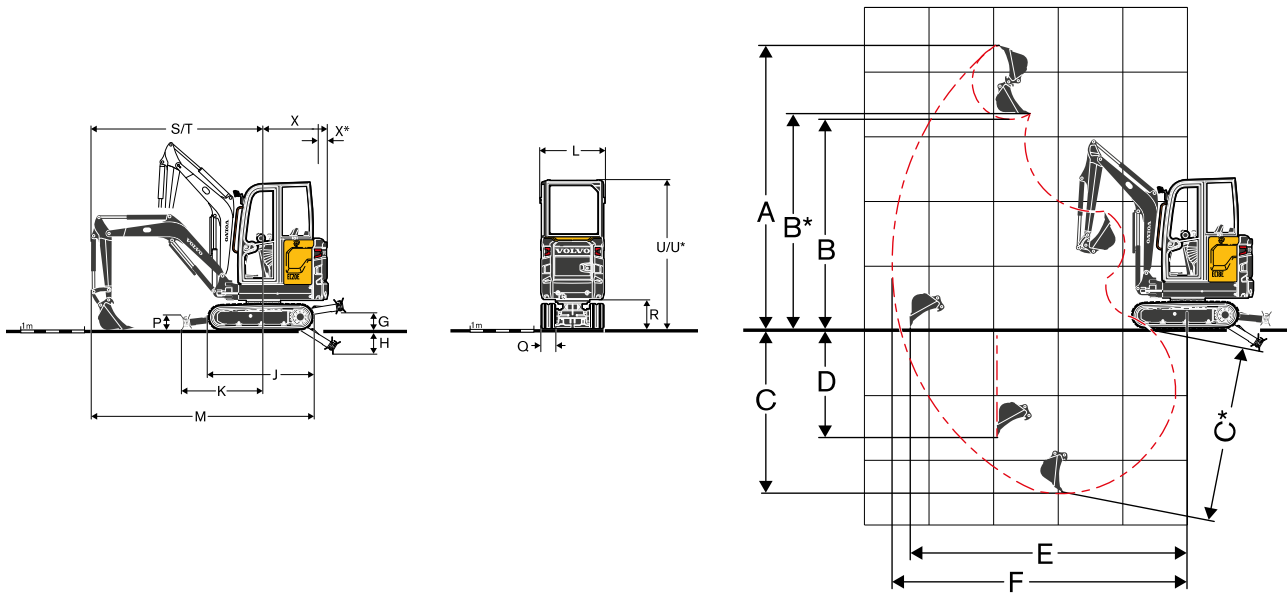

## DIMENSIONS

Description		Unit	EC20E	
<b>Arm</b>		<b>mm</b>	<b>1 050</b>	<b>1 350</b>
A	Maximum cutting height	mm	3 793	3 968
B	Maximum dump height	mm	2 621	2 796
B*	Maximum bucket clearance	mm	2 733	2 908
C	Digging depth	mm	2 279	2 579
C*	Maximum digging depth	mm	2 636	2 853
D	Maximum vertical wall digging depth	mm	1 713	1 999
E	Maximum digging reach at ground level	mm	3 976	4 266
G	Highest position dozer blade	mm		259
H	Lowest position dozer blade	mm		404
J	Track length	mm		1 620
K	Dozer blade, maximum reach at ground level	mm		1 288
L	Overall width with 230mm tracks	Min mm		995
		Max mm		1 352
M	Overall length	mm	3 707	3 554
M*	Transport length (arm lowered)	mm	4 145	4 100
P	Dozer blade height	mm		241
Q	Shoe width (rubber)	mm		230
R	Ground clearance to superstructure	mm		456
S	Front slew radius	mm	1 679	1 732
T	Front slew radius with maximum offset	mm	1 401	1 450
U	Overall height cab	mm		2 334
U*	Overall height canopy	mm		2 298
X	Tail slew radius	mm		1 018
X*	Rear overhang (across tracks)	mm		342
β <sub>1</sub>	Maximum boom offset to the right	mm		398
β <sub>2</sub>	Maximum boom offset to the left	mm		545

## Attachments specifications

Quick Coupler type	Unit	General Purpose buckets					Aggressive Cut buckets			Ditching buckets		Hydraulic breaker HB02 Low Noise
		250	300	400	500	600	350	550*	550	Fixed	Tilttable	
Volvo mechanical (pin-on)	l	28	32	47	63	78	-	-	-	76	59	-
Lehnhoff® mechanical	l	-	32	47	63	78	-	-	-	76	59	Pin-on bracket
Mechanical, symmetrical type	l	-	-	-	-	-	25	55	55	76	-	Symmetrical type bracket

\*with teeth

For more details, see Attachments catalogue

# Equipment

## STANDARD EQUIPMENT

### Engine

Low emission, water-cooled, Volvo 3-cylinder diesel engine, meeting EPA Tier 4 and EU Stage V environmental regulations

Starter motor protected against ignition when engine is already running

Automatic engine cut-off in case of overheating or low oil level

Engine starting safety device: the left console must be raised to operate the starter

Dry-type single element air filter

Water separator and translucent fuel filter

Plastic tank with drain plug

### Drivetrain

Automatic two-speed travel hydraulic motors with reduction gears

Inner flange bottom rollers lubricated for life

Grease tensioning wheel lubricated for life

### Electric / Electronic control system

Maintenance-free battery

IP67 protected electrical system and high quality connectors

Battery disconnect connector

Two working lights on cab version

Working light on the canopy frame

12V power socket in cab with cellular phone storage

### Swing system

Radial piston hydraulic motor with integrated shockless valve

Automatic multi-disc spring applied hydraulic released slew brake

Centralized and remote lubrication of crown wheel and ball bearing

### Superstructure

Stamped steel panels all-around, recessed 10 to 15mm

4 integrated tie-down points on upper structure

### Undercarriage

230mm rubber tracks

Box welded fabricated frame

Sturdy removeable protecting covers for track motors and slew system

Box section highly rigid dozer blade structure

Weld-on edge on dozer blade

230mm rubber tracks

### Hydraulic System

Variable displacement piston pump

Flow-Sharing and Load Sensing main control valve

Boom cylinder cushioning at end stroke (up)

Patented filtering and filling element

Large side by side oil cooler and radiator

Double-acting hydraulic circuit for accessories

Hydraulic hoses routed inside the boom for increased protection

Plastic tank with drain plug

### Cab / Canopy

Cushionned operator station

Large entrance access

Large and roomy uncluttered floor

Highly visible orange footstep

Highly visible orange seatbelt with warning indicator on display

Toolbox with integrated storage for operator's manual and lockable door

## STANDARD EQUIPMENT

### Cab

Highly visible orange handrail

Flat toughened glass all-around

Gas-strut assisted front window opening

Front windscreen wiper and washer nozzle

Right hand side sliding window

Heating systems with in-cab adjustment of temperature and air flow, and multiple air vents

Filtered air inlet

Radio preparation (antenna, wire harness)

### Digging Equipment

Casted end and structural parts on arm, pivot, undercarriage and upper structure nozzle

Monoblock box welded fabricated boom and arm

Boom cylinder protection

Long-life steel bushings & hardened, pre-lubricated and corrosion resistant pins

50-hours intervals on all grease points

### Machine control system

Automatic locking device for pilot controls and travel levers when the left console is raised

Proportional and adjustable fingertip control for boom offset and auxiliary circuit

Large travel pedals

Breaker (full flow) toggle switch on right joystick

Pressure accumulator to lower the equipment on the ground

### Instrumentation and monitoring

Permanent digital hour meter visible from outside cab

Warning lights for hydraulic filter and air filter restriction

Engine temperature and fuel level gauges

### Official approval

Machine conforming to European directive 2006/42/EC

Noise emissions in the environment conforming to directive 2000/14/EC

Hand Arm Vibrations - Whole Body Vibrations compliant with directive 2002/44/EC

Electromagnetic compatibility (EMC) conforming to European directive 2004/108/EC and its amendments

Object handling device conforming to EN 474-1 and EN 474-5 standards

ROPS (Roll-Over Protective Structure) conforming to ISO 3471-1 and SAE J1040 standards

TOPS (Tip-Over Protective Structure) conforming to ISO 12117 and EN 13531 standards

OPG 1 (Operator Protective Guard on top) conforming to ISO 10262 standard (when equipped)

---

**OPTIONAL EQUIPMENT**

---

**Engine**

- Dual stage air filter
- Auto idling system
- Engine auto shut-down with time adjustment

**Operator environment**

- Robust 4-pillar structure canopy
- Heated cab
- Vinyl seat with mechanical suspension, low back and 2" orange seatbelt
- Vinyl seat with mechanical suspension, extended back with lumbar adjustment and 2" orange retractable seatbelt
- Vinyl seat with mechanical suspension, extended back with lumbar adjustment and 3" retractable seatbelt
- Fabric seat with mechanical suspension, low back and 2" orange seatbelt
- Fabric seat with mechanical suspension, extended back with lumbar adjustment and 2" orange retractable seatbelt
- Fabric seat with mechanical suspension, extended back with lumbar adjustment and 3" retractable seatbelt
- Additional lockable storage box (behind the seat)
- Electrical switch for ISO/SAE control pattern change
- Travel alarm
- Radio, AUX, USB, Bluetooth
- Radio DAB, USB, Bluetooth, MP3
- Anti-theft, code lock
- Anti-theft, coded key
- Controls lock, switch
- Controls lock, seat operator presence and switch
- Controls lock, seatbelt sensor
- Front guard OPG1 for canopy
- Severe-duty guards for cab (OPG2, front & top)
- Tool kit

**Machine exterior**

- Left/Right rearview mirror
- One protected worklight on the boom
- One rear worklight
- Rotating beacon
- One protected worklight on the boom LED
- One rear worklight LED
- LED worklights package
- Warning beacon, flashing LED
- Green beacon link to safety belt
- Several level of customisation (RAL specifications) to match with your corporate identity

---

**OPTIONAL EQUIPMENT**

---

**Hydraulic equipment**

- Relief valve for auxiliaries
- Breaker/Shear valve
- Hydraulic drain for accessories
- Second accessory circuit with proportional and adjustable controls
- Kit 2 flat face hydraulic couplings
- Kit 4 flat face hydraulic quick couplings
- Double acting circuit for hydraulic quick couplers
- Boom and arm safety lifting valves
- Boom, arm and dozer blade safety lifting valves
- Safety valve certification
- Mineral hydraulic oil VG32
- Mineral hydraulic oil VG46
- Mineral hydraulic oil VG68
- Bio hydraulic oil VG32 (PANOLIN®)
- Bio hydraulic oil VG46 (PANOLIN®)

**Digging Equipment**

- Short arm
- Long arm

**Attachments**

- Volvo mechanical quick coupler (pin-on)
- Lehnhoff® mechanical quick coupler
- Symmetrical type mechanical quick coupler (S30)
- General Purpose buckets
- Fixed Ditching buckets
- Tilttable Ditching buckets
- Hydraulic breaker HB02LN

**V O L V O**