

**VOLVO COMPACT EXCAVATOR**

# **EC55B PRO**



**MORE CARE. BUILT IN.**



# THE MOST COMFORTABLE WAY TO APPROACH ANY JOB.

Sit behind the controls of the Volvo EC55B Pro Compact Excavator and you'll find an incredibly comfortable way to work. The spacious cab and ergonomic design gives you the room you need, while the standard air conditioning and low noise levels make even the longest days comfortable.

## We're ready for you

Volvo offers a wide range of compact excavators. From proven conventional designs to short swing radius designs, Volvo has the right machine for your work.

## Room to move around

The model EC55B Pro has a large, roomy cab to make even tall operators feel right at home. The flat floor is also wide and uncluttered, with plenty of room for your feet. The seat is fully adjustable for customization to suit your operating position.

## Controls at your fingertips

The joystick controls are mounted close to the armrests for convenience and are power-assisted for smooth, precise movements. There's also ergonomic forward and reverse travel pedals so you can reposition the machine while controlling the equipment with the joysticks. In addition, the instrument panel can be angled for at-a-glance monitoring.

## All-day comfort

The windscreen features a gas strut, making it easy to open and prop in place. There's also tinted windows and standard air conditioning with five vents for excellent cooling of the cab. A standard radio/cassette player with two speakers increases comfort. Noise-reducing seals and insulation dramatically reduce noise levels in and out of the cab. Operators will appreciate reduced fatigue while those working nearby will experience a safer environment.



- Ergonomic position forward and reverse travel pedals.



- Instrument panel can be angled.



- Wide cab offers plenty of legroom for better comfort.



- Standard air conditioning.
- Reduced internal and external noise for a safer jobsite.
- Large, spacious cab.



# DIG INTO THE MODEL EC55B Pro.

Tough jobs demand a machine that can dig into the job at hand and keep coming back for more. The model EC55B Pro has one of the highest breakout and tear-out forces in its class. And because it's easy to service, you'll be assured that it will always be ready to dig into your work.

## Start your engines

The model EC55B Pro features a proven 16-valve, 37 kW Volvo engine for power, performance and low fuel consumption. And the machine is built to dig, offering impressive bucket dig forces.

## Precise, smooth movement

The dipper motion is extremely fast for more productive cycle times. The optional long dipper arm provides even greater performance. In addition, the Total Power Control Hydraulic System provides total independence of movement for smooth, productive work cycles.

## Power where you need it

The EC55B Pro features a larger size lift cylinder and increased hydraulic system pressure for greater lifting capacity and increased productivity. The high quality hydraulic system stands up to severe, long cycle testing with reliability for the daily assault of your work. Increased hydraulic pressure in the auxiliary line adds greater attachment performance, faster cycle times and better operating economy.

## A versatile approach

There's a standard double-acting circuit for use with hydraulic equipment such as breakers and augers. The exclusive Volvo quickrelease coupling makes it easy to change buckets or attachments without leaving the cab.

## Made easy to service

Open the wide rear cover for total access to all critical checkpoints. It's also fast and easy to check service levels and change the oil.



- Powerful 16-valve STEP 2/TIER 2 Volvo engine.



- Two-stage air filtration system eliminates need for pre-air cleaner and helps increase engine life.



- Larger lift cylinder for a greater lift capacity.



- Mechanical or hydraulic quick-release coupling.
- Efficient main hydraulic pump helps optimise fuel consumption and improve productivity.
- Increased slope swing force/speed means more productivity.



# SAFETY IS ALWAYS THE TOP PRIORITY.

When it comes to your safety, Volvo never makes compromises. The model EC55B Pro has exactly what you need to stay safe, so you can concentrate on getting the job done. And the EC55B Pro is robustly built, to stand up to even the most punishing jobsite conditions.

## A sturdy, rigid design

The center of the undercarriage is X-shaped for better load distribution and sturdier operation in extreme conditions. The undercarriage is also very long for incredible stability, performance and comfort. The blade cylinder and the connections are well protected. The anti-vibration tracks provide smooth travel even at higher speeds. The counterweight is rounded and wraps around the sides to protect the engine cover, which is set back from the counterweight to protect it even more.

## We're strong and stable

The EC55B Pro offers an enhanced conventional design for greater digging performance. The larger, longer counterweight provides increased balance and lift capacity. The combination of increased hydraulic pressure and a heavier counterweight increases slope swing for fast cycle times during slope work.

For increased reliability and a higher resale value, boom support strength has been increased through a large 80 mm pin diameter and an additional bushing. This provides extra surface contact and greater shock absorption.

## Helping you work safely

The wide door and retractable console offer safe, easy access to the operator station. The machine won't start unless the console and safety lever are in position, and the controls lock out whenever either is raised to help prevent incidental movement. A safety valve on the dozer blade maintains the selected blade position. In addition, the instrument panel has a monitoring system that shut off the engine in case of a major problem.



- All controls lock out when safety lever is lowered.



- Volvo takes durability and reliability to new extremes.



- Strengthened boom support adds reliability.
- Counterweight wraps around the sides to protect the enginecover.
- Excellent visibility around the machine.







# SPECIFICATIONS

## Engine

Water-cooled Volvo 4-cylinder diesel engine.

<b>Model</b>	D3.1A
<b>Gross power, rated (ISO 9249)</b>	38.8 kW (52,1 hp) @ 2,100 rpm
<b>Power, installed (ISO 9249)</b>	37.2 kW (50 hp) @ 2,100 rpm
<b>Displacement, total</b>	3054 cc
<b>Maximum torque</b>	194~210 Nm @ 1,600 rpm ± 100 rpm
<b>Bore x stroke</b>	94 mm x 110 mm

## Electrical system

<b>Rated voltage</b>	12 V
<b>Battery capacity</b>	12 V - 100 Ah x 1EA
<b>Alternator rating</b>	12 V - 55 Ah
<b>Starter motor output</b>	12 V - 3.0 kW

## Hydraulic system

Variable displacement Total Power Control hydraulic system providing total independence of all movements and of travel.

<b>Control</b>	Power-assisted hydraulic controls
----------------	-----------------------------------

Variable displacement double pump for the equipment (boom, dipper and bucket) and travel circuits:

<b>Maximum flow</b>	2 x 52.5 l/min
<b>Maximum operating pressure</b>	22 Mpa (220 bars)

Gear pump for the power assistance circuit:

<b>Maximum flow</b>	9.5 l/min
<b>Maximum operating pressure</b>	35 bars

Double-acting hydraulic circuit for accessories:

<b>Maximum flow</b>	52.5 l/min
<b>Maximum operating pressure</b>	21 Mpa (210 bars)

### End-of-stroke cushion:

<b>On boom ram</b>	at the end of the rod extension
<b>On dipper ram</b>	on both sides
<b>On offset ram</b>	on both sides
<b>Offset ram lock</b>	

The equipment's offset ram is equipped with a balancing valve which holds the boom offset angle in the position chosen by the operator in all working conditions.

## Slewing system

Turntable slewing is provided by a radial piston hydraulic motor which drives directly (without a reduction gear) a ball internal crown wheel with remote lubrication.

<b>Slewing speed</b>	9,4 r/min
<b>Turntable braking</b>	automatic multi-disc brake
<b>Absorption of hydraulic shocks</b>	Shockless valve

## Bucket performance

<b>Breakout force</b>	4000 daN
<b>Tearout force</b>	2900 daN

## Undercarriage

The undercarriage is made up of an "X" box fabricated centre part for more rigidity and of sloping side members for a better clearance of materials. The rollers and the tensioning wheels are lubricated for life.

<b>Bottom/top rollers per side</b>	5/1
<b>Track width</b>	380 mm
<b>Track tension</b>	by grease piston
<b>Blade (width x height)</b>	1920 x 350 mm

## Travel system

Each track is driven by an axial piston hydraulic motor equipped with two gears and an epicyclic reduction gear. Braking is provided automatically by a multiple disc brake.

<b>Travel speed (low / high)</b>	2.2 / 4.1 km/h
<b>Max. tractive force</b>	4480 daN

The forward movement control is automatically locked when the operator raises the left console.

## Service fill capacities

<b>Fuel tank</b>	90 l
<b>Hydraulic system, total</b>	130 l
<b>Hydraulic tank</b>	90 l
<b>Engine oil</b>	10.1 l
<b>Cooling system</b>	11 l

## Weight

Weight and ground pressure with (250 mm) rubber tracks :

	Operating
<b>Cab version Weight</b>	5500 kg

## Noise level

The EC55B Pro conforms to the 2006 European Machine Directive Noise Level (2000/14/CE) of 97 dB(A) for this class of machine.

<b>Noise level exterior (LwA)</b>	97 dB(A)
<b>Noise level in the cab (LpA)</b>	78 dB(A)

The noise levels conform to directive n° 86/662 EEC and its amendments.

# SPECIFICATIONS

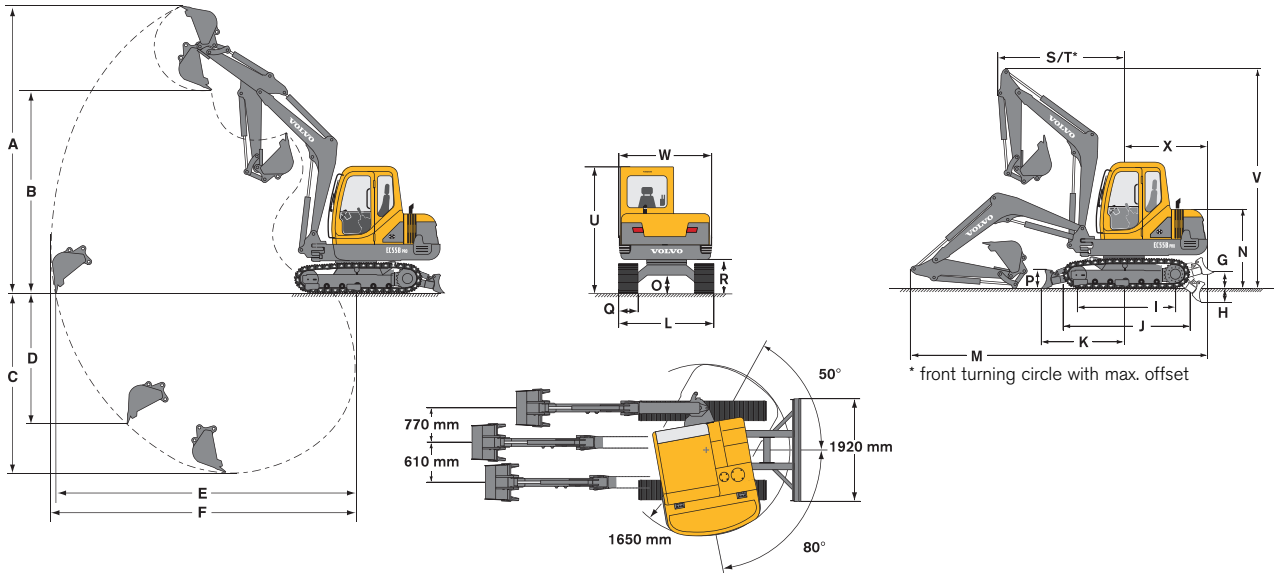

Buckets			
	Width	Weight	Capacity
Backhoe	350 mm	85 kg	70 l
	450 mm	97 kg	98 l
	600 mm	118 kg	142 l
	750 mm	138 kg	187 l
Ditch	900 mm	163 kg	231 l
	1500 mm	185 kg	265 l

Dipper	A	B	C*	C	D	E	F
1540 mm	5770	4090	4000	3820	2620	5980	6110
1900 mm	6010	4320	4360	4180	2990	6320	6450

\* Dig depth with the blade down.

G	H	I	J	K	L	M	N	O
350	450	1950	2500	1610	1920	5920	1600	380

P	Q	R	S	T	U	V	W	X
360	400	690	2360	2330	2560	4470	1840	1670

These capacities are given for a machine without a bucket or quick-release coupling and fitted with rubber tracks. The handling capacity is 75% of the tipping load or 87% of the hydraulic limit.

Caution: In accordance with standard EN 474-5, the machine must be fitted with a safety valve on the boom ram and with an overload indicator for handling operations.

Horizontal Range		2 m	3 m	4 m	Maxi. 5,5 m
	Z2	-	-	1340°	1340°
	Z1	3220*	2180*	1610*	1350*
	Z3	3060*	2050*	1420*	1380*
	Z2	-	-	-	730
	Z1	2530*	1310	1020	620
	Z3	2590*	1340	880	950

Horizontal Range		2 m	3 m	4 m	Maxi. 5,8 m
	Z2	-	-	1150°	1210°
	Z1	1450*	2440*	1470*	1230*
	Z3	1910*	2220*	1560*	1140*
	Z2	-	-	1030	650
	Z1	1450*	1090	860	560
	Z3	1910*	1010*	870	790

\* hydraulic limit

In kg



Lifting capacity with the blade resting on the ground.



Lifting capacity in total rotation over 360° with the blade raised.

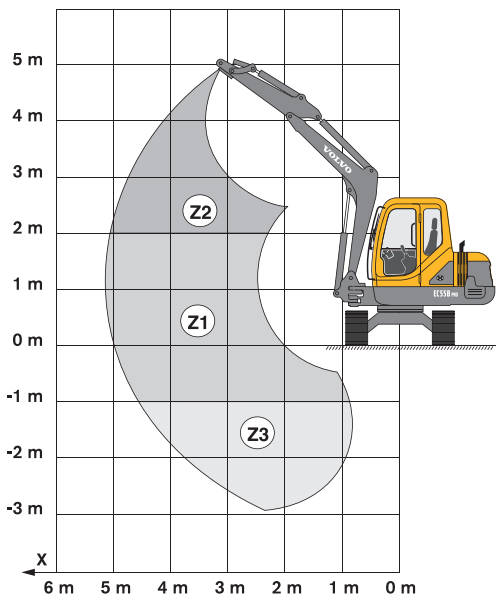

## STANDARD EQUIPMENT

### Engine

Low-emission engine meeting step 2 environmental regulations.  
Two-stage air filter with blinding indicators.  
Electric heating device.  
Diesel filter and sediment chamber.  
Electric fuel tank filling pump (35 l/min).  
Oil sump sheet metal.  
Smooth sound dual case muffler.

### Electrical system

Maintenance-free 12 V - 100 AH battery.  
Starter motor 12 V - 2.3 kW.  
Halogen working lights (2 on the turret and 1 on the boom).  
Horn.

### Undercarriage

(400) mm wide rubber tracks.  
Dozer blade.  
Remote lubrication of the slew ring.

### Hydraulic system

ISO power-assisted hydraulic control.  
Cylinder cushions with contamination seals.  
Total Power Control system.  
Boom anti-lowering device.  
Multiple filtration system (30 µm).  
Double-acting hydraulic circuit for accessories fitted on the boom.  
Power-assisted control of the hydraulic offset of the boom by the left manipulator.  
Auxiliary hydraulic valve port for hammer.  
Control of forward and backward movement by two levers coupled to pedals.

### .Cab

Heating and air conditioning.  
Tinted windows.  
ROPS (Roll-Over Protective Structure).  
TOPS (Tilt-Over Protective Structure).  
Fabric-covered multi-adjustable sprung seat.  
Non-slip floor and grab handle for access to the driver's cab.  
Seatbelt.  
Adjustable control console.  
Hinged front window.  
Removable bottom front window.  
Sliding right side window.  
Rear Mirror in Cabin.  
Rubber mounting.  
Radio/cassette player with 2 speakers.  
Flexible aerial.  
Interior lighting.  
Intermittent windscreen wiper and windscreen washer on the front window.  
Ashtray.  
Cigar lighter.

### Instrumentation and monitoring

Monitoring and warning light for the following functions: pre-heating, engine oil pressure, water temperature, battery charge, air filter clogging.  
Internal and external fuel gauges.  
Hour meter.

### Handling and earthwork equipment

(3030 mm) long monobloc boom.  
(1540 mm).  
Remote lubrication of the offset and dipper arm cylinders.

### Safety

Device for locking the controls when the left console is raised or safety lever is down to gain access to the driver's cab.  
Safety valve on the blade cylinder.  
Pressure accumulator on the power assistance circuit in order to be able to put the equipment on the ground if the engine is switched off.  
Window-breaker hammer (cab).

### Official approval

Machine conforming to EC directive n° 89/392 and its amendments.  
Soundproofing conforming to EC directive n° 86/662 and its amendments.  
Handling device conforming to EN standard 474-5 (Option).  
ROPS conforming to ISO standard 3471/SAE J 1040.  
TOPS conforming to ISO standard 12117.

---

## Optional equipment

### Handling and earthwork equipment

(1900 mm) Dipper arm.  
Safety valve piloted by the power assistance circuit on the boom arm cylinder with overload indicator.  
Safety valve on the dipper arm cylinder.  
Quick-release accessories coupling.  
Hydraulic quick coupler.  
Heavy-duty dipper arm.

### Undercarriage

Steel tracks: (380 mm) wide.

### Lighting

Additional front and rear working light.  
Turning beacon.

### Environmental protection

Bio degradable hydraulic oil.

### Safety

Anti-theft device coded by digicode keypad (2 programmable codes).  
FOPS1/FOG windscreen guard.

### Miscellaneous

Special customised paint (RAL specifications).  
Right and left rear sides view mirrors.  
Pilot control change valve.



Volvo Construction Equipment is different. It's designed, built and supported in a different way. That difference comes from an engineering heritage of over 170 years. A heritage of thinking first about the people who actually use the machines. About how to help them be safer, more comfortable, more productive. About the environment we all share. The result of that thinking is a growing range of machines and a global support network dedicated to helping you do more. People around the world are proud to use Volvo. And we're proud of what makes Volvo different – **More care. Built in.**



*All products are not available in all markets. Under our policy of continuous improvement, we reserve the right to change specifications and design without prior notice. The illustrations do not necessarily show the standard version of the machine.*

# **VOLVO**

**Volvo Construction Equipment**  
[www.volvo.com](http://www.volvo.com)

Ref. No. 21 2 432 1170  
Printed in Sweden  
Volvo, Belley

English  
2006.12  
CEX