

V O L V O



Volvo Single Drum Compactors 7.1-16.5 t 55-123 kW

**SD75B, SD115B,
SD135B, SD160B**

Volvo Construction Equipment

Versatile performance

Volvo B-series soil compactors are packed with advanced technology. The drum is configured with ease while the engine controls itself. The compactors adapt to your application and jobsite to provide maximum versatility and performance.

Frequency and amplitude choices

Easily adjust the vibration frequency from the operator console to compensate for changing soil types and conditions. Two frequency settings are standard and for even greater versatility, five frequency option is available. High and low amplitudes can also be selected.

Multiple engine options

For markets where ultra low sulfur diesel fuels are not readily available, the SD115B-SD160B can be equipped with an optional Stage IIIA engine. For markets with ultra low sulfur fuel, a Stage V engine is available.



Application versatility

The machine can be set up in three different configurations and is available with smooth or padfoot drum. The compactor is quickly and easily converted from a smooth drum by clamping on a padfoot shell. The padfoot shell kit allows the machine to work in different applications and increases versatility.

Drum performance

Volvo's advanced drum control system delivers multiple frequencies, dual amplitude, and optimized centrifugal force – matching the drum's performance to your application. The choice of high or low amplitude is easily selected, giving you the flexibility to adjust the drum's dynamic force based on the job and material depth. The auto vibration feature also increases ease of operation and productivity.





HIGH TRACTION VARIANT

The Volvo traction system provides excellent climbing and traction capabilities in difficult applications. For the most demanding applications, the High Traction variant is available, delivering additional torque to easily climb extreme slopes. Also included in this variant is the 5 frequencies feature, adding further productivity to your machine.

Power up, fuel down

The perfectly optimized Volvo engine delivers high torque at low rpm for superior performance and low fuel consumption. The engine has been developed to offer greater fuel efficiency, increasing uptime and reducing costs.

Efficient cooling system

The hydraulically-driven fan with variable speed draws power only when needed. Lower fan speeds reduce noise, resulting in greater operator comfort and a lower total cost of ownership.



ECO mode

ECO mode is now standard and always on by default. It adjusts the engine speed to match the operation mode and achieves up to a 40% reduction in fuel consumption.

**Not applicable to SD75B, SD160B*

Passive regeneration

Volvo's passive regeneration provides continuous and simplified operation. The filters are cleaned automatically during operation without any input from the operator or effect on performance.

**Not applicable to optional Stage IIIA engine*



Eccentric design

The eccentric design delivers more efficiency while using less power. Matching the required performance to suit your application, the eccentric is designed for faster ramp up speeds at lower pressure for increased fuel efficiency.





VOLVO ENGINE

Volvo's premium Stage V engine delivers high torque at low rpm for superior performance and low fuel consumption. Designed to lower emissions and increase efficiency without compromising power. An optional Stage IIIA engine is also available.

Packed with intelligence

Compact Assist

Achieve optimum compaction results with less effort thanks to the suite of Compact Assist tools, powered by the 10" Volvo Co-Pilot touchscreen.

ECO mode

ECO mode is now standard and always on by default. It adjusts the engine speed to match the operation mode.

Drum performance

Volvo's advanced drum control system delivers multiple frequencies, dual amplitude, and optimized centrifugal force.

Heavy-duty drum

The heavy-duty drum, center joint and front frame components are designed and manufactured with durability in mind.

Frequency and amplitude choices

Easily adjust the vibration frequency from the operator console to compensate for changing soil types and conditions.

High quality components

The compactor features the highest quality components, clever routing and clean design.



Volvo engine

The perfectly optimized Volvo engine delivers high torque at low rpm for superior performance and low fuel consumption.

Passive regeneration

Passive regeneration functions automatically during operation without input from the operator or effect on machine performance.

**Not applicable to optional Stage IIIA engine*

Service access

The electric engine hood lifts up giving extensive ground level access to the engine compartment.

ActiveCare

Maximize machine uptime and reduce repair costs with ActiveCare, providing 24/7 machine monitoring as well as weekly reports.

High Traction variant

The Volvo traction system provides excellent climbing and traction capabilities in difficult applications. The High Traction variant is also available for the most demanding applications.



Compact Assist

Achieve optimum compaction results with less effort thanks to the suite of Compact Assist tools, powered by the 10" Volvo Co-Pilot touchscreen. From simple compaction measurements, right through to complete tracking of both the coverage and compaction of the material, Compact Assist for Volvo Soil Compactors comes available in a number of packages to match the needs of your business.

Compact Assist Lite

Take your first steps towards improving the quality of your work with Compact Assist Lite. It integrates a compaction gauge and rearview camera within the Volvo Co-Pilot monitor, allowing the operator to track the progress of current and recently completed compaction, and giving them a clear view behind the machine. Upgrading to Compact Assist Start or Compact Assist in the future is easy.



Compact Assist Start

This package includes the functionality of Lite, plus the ability to see completed work across the entire jobsite. It uses GPS data to provide the operator with a clear map of passes and Compaction Measurement Value (CMV).



Compact Assist

This package includes all the functionality of Start, plus high accuracy location and data recording. It enables the creation of reports on the finished job and provides access to extensive detail on the performance of the roller, without the need for any post processing.

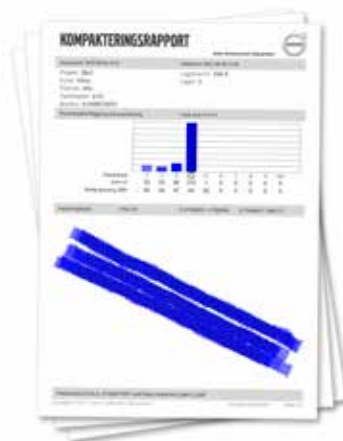

Control in comfort

Step up to the Volvo designed cab and experience industry-leading low noise levels, ultimate comfort and a productive working environment. Safe, spacious and with improved all-around visibility, operators will work efficiently with less fatigue in a Volvo compactor.

Operator environment

The ROPS/FOPS certified cab provides a safe and comfortable working environment with an efficient heating and air conditioning system and all-around visibility. With floor to ceiling cab glass, the operator has an excellent forward drum view as well as superior front and rear visibility.

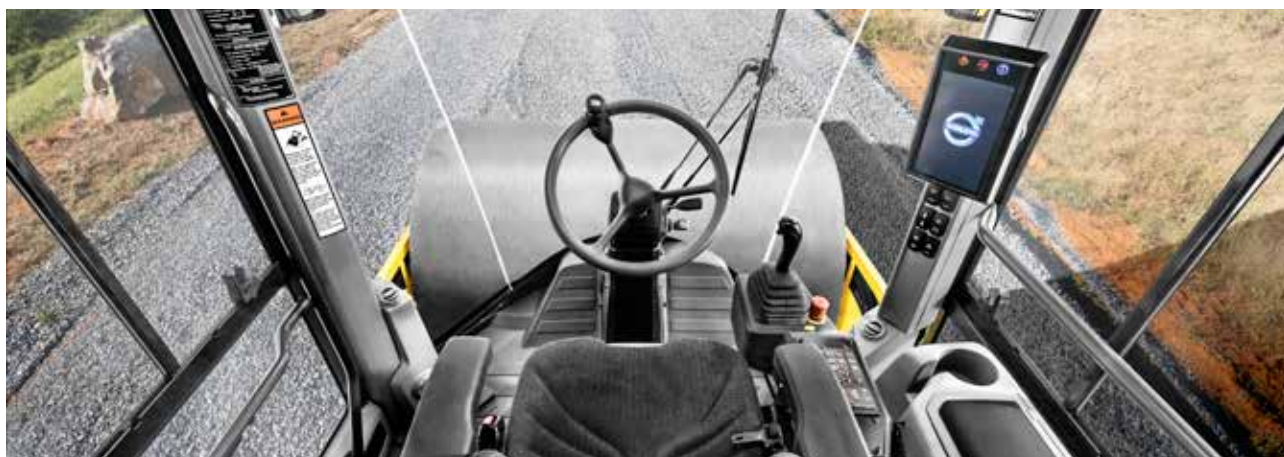

Climate control system

The cab is equipped with industry-leading climate control to ensure a comfortable environment inside the cab, whether heating or air conditioning is required. High air intake and positive cabin pressure helps to reduce dust from entering the cab.

Fully adjustable seat

The fully adjustable seat rotates and slides to enhance front and rear visibility for increased safety and comfort.



Robust and reliable

Volvo Construction Equipment produces the most robust and durable compactors on the market. The B-series soil compactors provide easy service access for increased uptime and quick maintenance.

Service access

The cab tilt is standard, providing access to all hydraulic components. For class-leading access, the electric engine hood lifts up giving extensive ground level access to the engine compartment. Maintenance and inspections can be conducted more efficiently with minimal downtime – increasing overall productivity and reliability.



Sealed electronics

All components and electronics have been moved into the cab and mounted on the rear wall, protecting them from the elements. Fuses are accessible behind the fuse panel for improved accessibility.

Machine monitoring made easy

Maximize machine uptime and reduce repair costs with the CareTrack telematic system. Choose to keep track of your machine yourself or let us take care of it with ActiveCare. Our Volvo Uptime Center will provide 24/7 machine monitoring, supplying weekly reports and notifying you should preventive maintenance action be required.



Heavy-duty drum

The heavy-duty drum, centre joint and front frame components are designed and manufactured with durability in mind. The thick steel drum shell is engineered for longevity and performance. Frames are robotically welded and built from high quality steel with precise and consistent welds guaranteeing a strong structure.





HIGH QUALITY COMPONENTS

The compactor features the highest quality components, clever routing and clean design. The engine, hydraulics and electronic components work in harmony to deliver superior performance and increase machine life.

Specifications

Stage IIIA models		SD115B		SD135B		SD160B	
Drum type		Smooth	Padfoot	Smooth	Padfoot	Smooth	Padfoot
Machine Weights (inc. cab and inside scraper)							
Operating Weight (CECE)	kg	11 315	11 475	12 175	12 875	16 382	17 085
Static Weight @ Drum	kg	6 000	6 160	6 860	7 560	10 802	11 505
Static Weight @ Tyres	kg	5 315	5 315	5 315	5 315	5 580	5 580
Shipping Weight	kg	11 083	11 243	11 943	12 643	16 150	16 853
Drum							
Width	mm	2 134	2 134	2 134	2 134	2 134	2 134
Diameter	mm	1 500	1 295	1 510	1 510	1 510	1 510
Shell Thickness	mm	25	25	30	30	30	30
Diameter Over Pad Feet	mm	-	1 549	-	1 764	-	1 764
Pad Feet	number of	-	112	-	120	-	120
Pad Height	mm	-	127	-	127	-	127
Pad Tip Area	cm ²	-	135.3	-	135.3	-	135.3
Vibration							
Frequency	Hz	30.8/33.8	30.8/33.8	30.8 / 33.8	30.8 / 33.9	23.3-31.3 (5x frequency)	23.3-31.3 (5x frequency)
Optional 5 Frequency (High Amp)	Hz	23.3 - 30.8	23.3 - 30.8	23.3 - 30.8	23.3 - 30.8	-	-
Centrifugal Force	High Amp	kN	253	253	281	281	291
	Low Amp	kN	214	214	249	249	249
Nominal Amplitude	High Amp	mm	1.92	1.82	1.87	1.6	1.86
	Low Amp	mm	1.5	1.42	1.38	1.17	1.37
Propulsion							
Type	Hydrostatic						
Tires	23.1-26 R3 8PR TT		23.1-26 R1 8PR TL		23.1-26 R3 8PR TL		23.1-26 R1 8PR TL
Drum Drive	Planetary Gear Box						
Travel Speed							
	High	km/h	0-8.8	0-9.0	0-8.8	0-9.5	0-11.5
	Low	km/h	0-4.2	0-4.2	0-4.2	0-4.7	0-4.8
Optional Engine							
Make / Model	Volvo D5E UN R96 I (Similar to Stage IIIA/Tier 3)						
Engine Type	Turbocharged 4-cylinder						
Rated Power @ 2000 r/min	kW	123					
Electrical System							
Voltage (Negative ground)	Volt	24					
Alternator	Ah	80					
Batteries	CCA	2 x 1 000					
Brakes							
Service	Hydrostatic						
Parking / Secondary	Spring-applied, hydraulically released on drum and axle						
Miscellaneous							
Articulation Angle	°	+/- 35					
Oscillation Angle	°	+/- 12					
Inside turning radius	mm	3 800					
Fuel Capacity	L	251					
Hydraulic Oil Capacity	L	75					
Guaranteed Sound Level							
Operator's Ear, acc. to ISO 11203:2009	L _{pA} dB	75 (Cab) - 87 (Canopy)				79 (Cab)	
External, acc. to Directive 2000/14/EC	L _{WA} dB	105				105	

Stage V models		SD75B		SD115B		SD135B		SD160B	
Drum type		Smooth	Padfoot	Smooth	Padfoot	Smooth	Padfoot	Smooth	Padfoot
Machine Weights (inc. cab and inside scraper)									
Operating Weight (CECE)	kg	7 192	7 368	11 743	11 900	12 600	13 300	16 691	17 392
Static Weight @ Drum	kg	3 610	3 786	6 293	6 450	7 150	7 850	10 976	11 677
Static Weight @ Tyres	kg	3 582	3 582	5 450	5 450	5 450	5 450	5 715	5 715
Shipping Weight	kg	7 081	7 257	11 613	11 770	12 470	13 170	16 561	17 262
Drum									
Width	mm	1 676	1 676	2 134	2 134	2 134	2 134	2 134	2 134
Diameter	mm	1 215	1 207	1 500	1 295	1 510	1 510	1 510	1 510
Shell Thickness	mm	20	16	25	25	30	30	30	30
Diameter Over Pad Feet	mm	-	1 354	-	1 549	-	1 764	-	1 764
Pad Feet	number of	-	84	-	112	-	120	-	120
Pad Height	mm	-	75	-	127	-	127	-	127
Pad Tip Area	cm ²	-	135.3	-	135.3	-	135.3	-	135.3
Vibration									
Frequency	Hz	30.8/33.8	30.8/33.8	30.8/33.8	30.8/33.8	30.8 / 33.8	30.8 / 33.9	23.3-31.3 (5x frequency)	23.3-31.3 (5x frequency)
Optional 5 Frequency (High Amp)	Hz	23.3 - 30.8	23.3 - 30.8	23.3 - 30.8	23.3 - 30.8	23.3 - 30.8	23.3 - 30.8	-	-
Centrifugal Force	High Amp	kN	139	139	258	258	281	281	291
	Low Amp	kN	121	121	242	242	249	249	249
Nominal Amplitude	High Amp	mm	1.94	1.71	1.92	1.82	1.87	1.6	1.86
	Low Amp	mm	1.41	1.25	1.5	1.42	1.38	1.17	1.37
Propulsion									
Type	Hydrostatic								
Tires		14.9-24 R3 6PR TT	14.9-24 R1 6PR TL	23.1-26 R3 8PR TT	23.1-26 R1 8PR TL	23.1-26 R3 8PR TT	23.1-26 R1 8PR TL	23.1-26 R3 8PR TT	23.1-26 R1 8PR TL
Drum Drive	LSHT Motor			Planetary Gear Box					
Travel Speed									
	High	km/h	0-12.3	0-12.9	0-10.1	0-10.0	0-9.9	0-10.4	0-11.5
	Low	km/h	0-6.5	0-7.5	0-4.4	0-4.3	0-4.2	0-4.7	0-4.9
Engine									
Make / Model	Volvo D3.8 Stage V				Volvo D4 Stage V				
Engine Type	Turbocharged 4 cylinder				Turbocharged 4-cylinder				
Rated Power @ 2 200 r/min	kW	55.4			110				
Electrical System									
Voltage (Negative ground)	Volt	12			24				
Alternator	Ah	100			80			120	
Batteries	CCA	1 x 1 000			2 x 1 000				
Brakes									
Service	Hydrostatic								
Parking / Secondary	Spring-applied, hydraulically released on drum and axle								
Miscellaneous									
Articulation Angle	°	+/- 38			+/- 35				
Oscillation Angle	°	+/- 12			+/- 12				
Inside turning radius	mm	3 249			3 800				
DEF Tank Capacity	l/gal	-			20/5				
Fuel Capacity	L	115			165				
Hydraulic Oil Capacity	L	60			75				
Guaranteed Sound Level									
Operator's Ear, acc. to ISO 11203:2009	L _{pA} dB	74 (Cab) - 87 (Canopy)			75 (Cab) - 87 (Canopy)			79 (Cab)	
External, acc. to Directive 2000/14/EC	L _{WA} dB	104			105			105	

Specifications

GRADEABILITY

Model	SD75B		SD115B		SD135B		SD160B	
Drum type	Smooth	Padfoot	Smooth	Padfoot	Smooth	Padfoot	Smooth	Padfoot
No traction enhancement	Moderate						-	
With flow divider option	High						-	
With High Traction variant (includes flow divider and high torque axle options)	-		Extreme				High	

Moderate applications include highway construction, finish grades, and slopes up to 30%.

High applications include trenching, infrastructure projects, and slopes ranging from 25% to 40%.

Extreme applications include thick lifts of loose material, use of leveling blades, and slopes over 30% such as landfills.

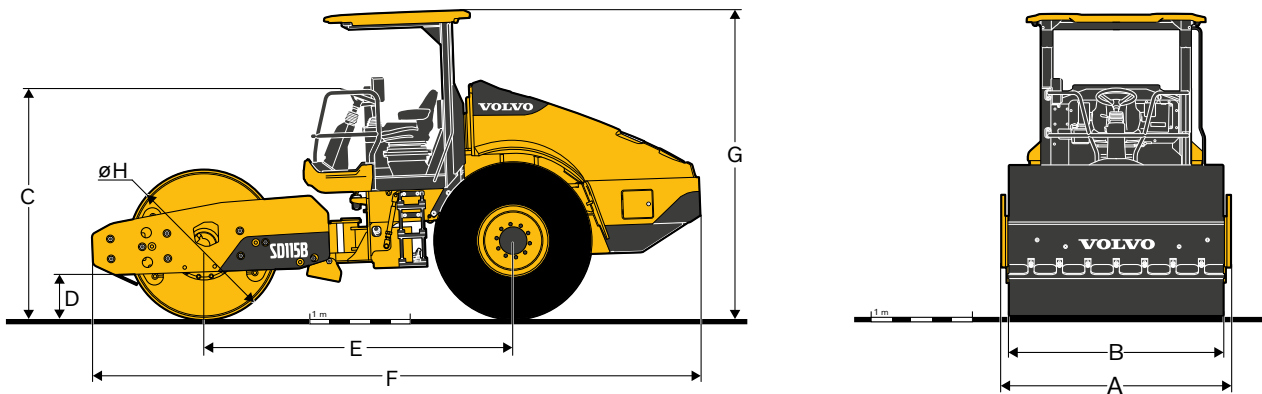

DIMENSIONS

Unit	SD75B		SD115B		SD135B		SD160B		
	Smooth drum	Padfoot drum	Smooth drum	Padfoot drum	Smooth drum	Padfoot drum	Smooth drum	Padfoot drum	
A	mm	1 830	1 830	2 286	2 286	2 286	2 286	2 406	2 406
B	mm	1 676	1 676	2 134	2 134	2 134	2 134	2 134	2 134
C	mm	2 183	2 252	2 269	2 288	2 269	2 288	2 359	2 311
D	mm	383	452	483	498	483	609	483	609
E	mm	2 677	2 677	3 095	3 095	3 095	3 095	3 095	3 095
F	mm	5 044	5 044	6 091	6 091	6 091	6 091	6 148	6 148
G	mm	2 924	2 993	3 000	3 020	3 000	3 020	3 090	3 020
H	mm	1 215	1 354	1 500	1 549	1 510	1 764	1 510	1 764

Equipment

SELECTION OF VOLVO OPTIONAL EQUIPMENT

Tires



Padfoot drum



Blade



Work lights



Compact Assist

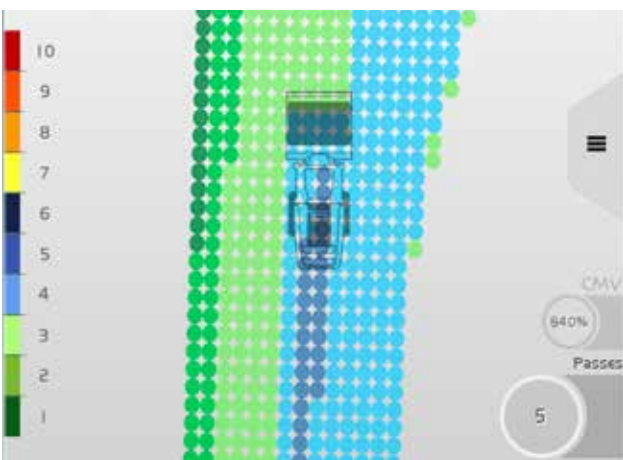

High Traction variant



Not all products are available in all markets. Under our policy of continuous improvement, we reserve the right to change specifications and design without prior notice. The illustrations do not necessarily show the standard version of the machine.

V O L V O