



Volvo Construction Equipment

DD120C, DD140C

Volvo Double Drum Compactors 12.6-13.8 t (27,700-30,500 lb), 110 kW (148 hp)



A passion for performance

At Volvo Construction Equipment, we're not just coming along for the ride. Developing products and services that raise productivity – we are confident we can lower costs and increase profits for customers around the globe. Part of the Volvo Group, we are passionate about innovative solutions to help you work smarter – not harder.

Helping you to do more

Doing more with less is a trademark of Volvo Construction Equipment. High productivity has long been married to low energy consumption, ease of use and durability. When it comes to lowering life-cycle costs, Volvo is in a class of its own.

Designed to fit your needs

There is a lot riding on creating solutions that are suited to the particular needs of different industry applications. Innovation often involves high technology – but it doesn't always have to. Some of our best ideas have been simple, based on a clear and deep understanding of our customers' working lives.



You learn a lot in 180 years

Over the years, Volvo has advanced solutions that have revolutionized the use of construction equipment. No other name speaks Safety louder than Volvo. Protecting operators, those around them and minimizing our environmental impact are traditional values that continue to shape our product design philosophy.

We're on your side

We back the Volvo brand with the best people. Volvo is truly a global enterprise, one that is on standby to support customers quickly and efficiently – wherever they are.

We have a passion for performance.

A strong, dedicated, capable dealer network

Our dealers are strategically located throughout North America to provide the equipment you need and the parts and service support you demand for a productive and profitable operation.

The strength of our dealer network is enhanced with extensive individualized product support training at our best-in-class Customer Center in Shippensburg and through hands-on training. Using a great Product Demonstration Center featuring a dedicated area for most common applications, visitors operate equipment from our entire product line under a variety of simulated working conditions. This facility is in year-round use by our dealers and customers.

Building the best starts right here.

The products designed and manufactured by Volvo Construction Equipment have their beginnings at the most advanced Research & Design centers in the industry. Volvo CE machines are designed in 11 R&D centers and produced in 15 manufacturing facilities across the world.

The major R&D center and manufacturing plant in the Americas is located in Shippensburg, Pennsylvania. This facility has been in operation for over 30 years and – with its recently added 200,000 sq. ft. expansion – now covers 570,000 sq. ft. on an 80 acre campus. Dedicated work teams and highly advanced technologies and techniques using the Volvo Production System ensure continuous quality improvements, labor savings and cost control to reach the high quality that our customers have come to expect from Volvo.





Volvo Trucks



Renault Trucks



Mack Trucks



UD Trucks



Volvo Buses



Volvo Construction Equipment



Volvo Penta



Volvo Financial Services

Perfecting performance

Our next generation of compactors provide you with a smooth, high quality finish for ultimate performance while optimizing fuel efficiency. With the superior drum vibration system and high centrifugal force, the C-Series asphalt compactors achieve more work in fewer passes. Unobstructed visibility, operator comfort and auto-reversing eccentrics enhance productivity, making the compactors ideal for large-scale projects.

More work, fewer passes

Achieve target density with the Volvo C-Series compactors, which combine high centrifugal force and 8-amplitude option, so you can do more work in fewer passes. Ensure high quality compaction thanks to the advanced Volvo drum vibration system, designed to diminish start up power consumption for optimum performance. Enhance pavement rideability with auto-reversing eccentric rotation.



Unobstructed visibility

Maximize safety with the C-Series compactors from Volvo, boasting impressive all-around visibility of the work zone and surroundings. The 180° rotating console and adjustable seat offer a commanding view of the jobsite, as well as unobstructed sightlines of the drum edges for rolling precision combined with full width drum surface monitoring.



Comfortably productive

Take on challenging conditions from the comfort and safety of the ROPS/FOPS platform, packed with productivity-enhancing features to keep the operator fresh, alert and focused. The operator environment offers noise and vibration isolation as well as ample storage and legroom, while easy-to-reach controls optimize productivity.



Drive your costs down

Keep operating costs low with the premium Volvo Tier 4 Final engine, delivering high torque at low rpm for superior performance and high fuel efficiency. The adaptive engine control system delivers optimum power for the task at hand. Reduce fuel consumption further with optional auto-idling and auto-engine shutdown features, optimizing efficiency without compromising power or performance.





BIG PROJECTS, BIG PERFORMANCE

Big projects demand a big performance and the DD120C-DD140C drum vibration system delivers the power and efficiency required to achieve optimum compaction results. Rely on the advanced drum control systems to deliver a smooth, high quality finish.



INTELLIGENT COMPACTION

Unlock the full potential of your machine with Compact Assist, the optional Intelligent Compaction system. For an efficient job, Intelligent Compaction offers real-time insight into the work using pass mapping and temperature mapping. With easy access to detailed data, the operator is able to eliminate any destructive over-compaction and track density values using Intelligent Compaction with Density Direct.

Peerless productivity

The new Volvo C-Series compactors are primed with a range of intelligent features to boost productivity. Unparalleled drum-wetting is achieved with water burst mode and adjustable flow-rate via the control panel for optimal water usage. Rely on Compact Assist and the Impact Spacing Meter to ensure full functional control. Whether you're on the machine or in an office, monitor your machine to secure peerless productivity and high profits.

Productivity on tap

Boost productivity with the unique burst mode which runs water pumps and spray bars for 10 seconds, to coat the drums and prevent material pickup. A new water flow-rate calibration process allows the operator to set the minimum flow according to requirements. Optimize water use with the automatic spraying system, providing variable flow proportional to speed, for consistent drum coverage.



Target compaction

Always travel at the right speed with the Impact Spacing Meter from Volvo, designed to ensure target compaction. The colored indicators are integrated into the display and allow the operator to measure impact spacing in order to aim for optimal 'green zone' use, to ensure a smooth, uniform finish.



Machine monitoring made easy

Use the new industry-leading on-board display to access real-time operational information and key diagnostics. Stay informed, receive reports and alarms with CareTrack, Volvo's telematics system. Monitor machine productivity on-board and plan servicing more efficiently, to save time and costs.



Roll with the experts

With a rich heritage of engineering excellence, you can count on Volvo Construction Equipment to design durable machines, built to work harder and longer. As road experts, our mission is to keep your machines working at the optimum efficiency and productivity required for the job. We help protect your business and your profits from the ground up.



Maximize uptime

Maximize uptime with easy maintenance of the compactors. Volvo's intelligent design includes the industry-leading swing-up hood for easy service access and passive regeneration which reduces downtime. Durable design, robustly tested components, and an extensive dealer and service infrastructure combine to maximize uptime. Manage your operating costs with our Customer Support Agreements.

New mode of regeneration

Passive regeneration occurs in the background as filters are cleaned automatically during normal operation without any input from the operator or effect on performance. A full regeneration is carried out by technicians as part of a routine 500-hour service.



Durable by design

Built to work, the durable compactor is designed to withstand the harshest conditions using high quality components with detailed engineering in mind. The robust structure features protected components and intelligent hose routing to secure machine uptime and profitability to your business. Retain Volvo quality with Genuine Volvo Parts, extensively tested because every part is vital for uptime and performance.



Control service costs

We can help support the profitability of your operation. The range of Customer Support Agreements offers preventive maintenance, total repairs and a number of uptime services. Volvo uses the latest technology to monitor machine operation and status, giving you advice to increase machine uptime. By having a Customer Support Agreement you are in control of your service costs.



Here to support you

Volvo is here to support you whenever you need it. As a complete solutions provider, we listen to your requirements to ensure machine uptime and availability. With extensive dealer coverage and trained technicians, Volvo has a comprehensive network to fully support you using local knowledge and experience.



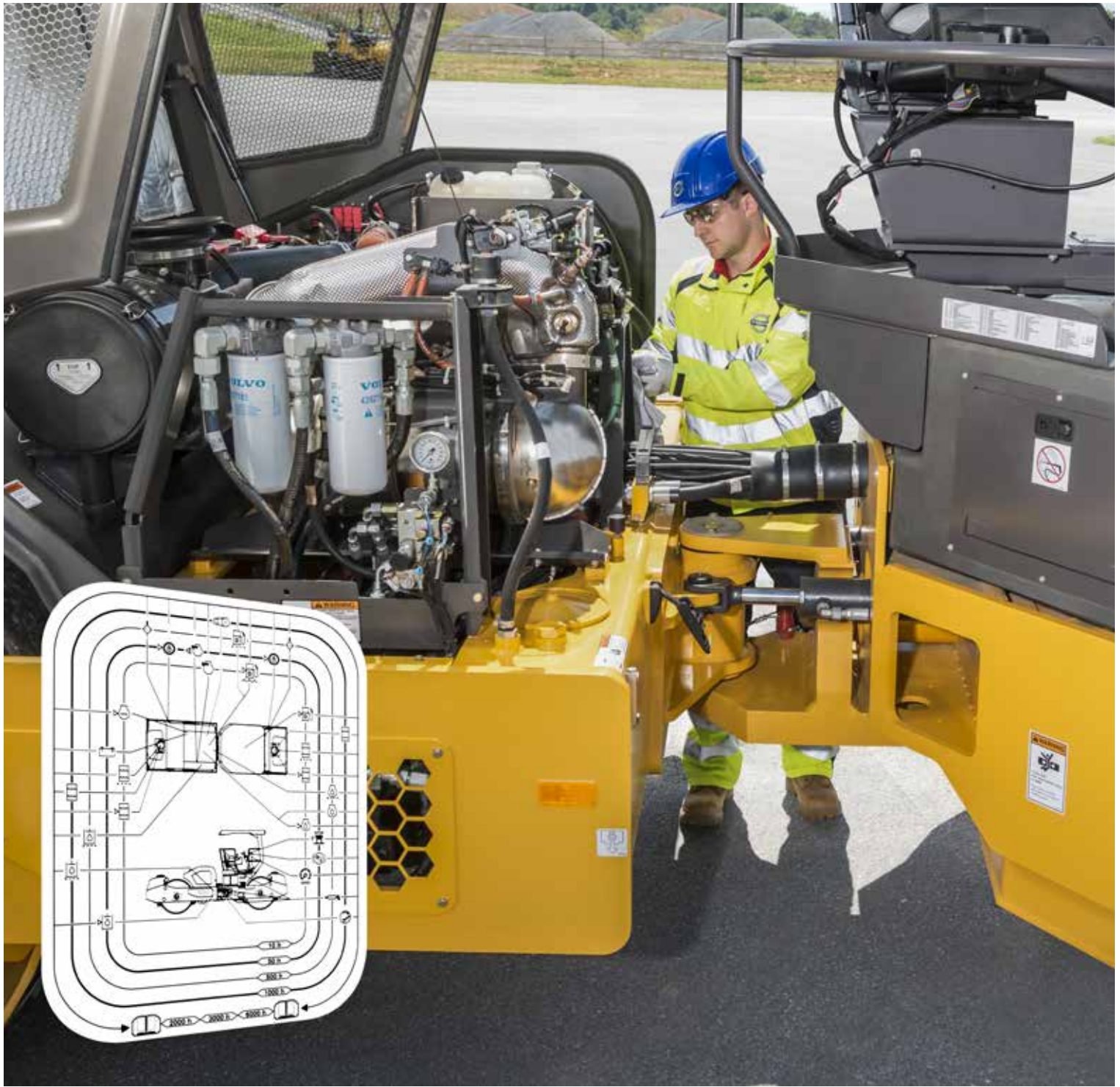

EASY MAINTENANCE

Quickly and safely perform routine maintenance with the intelligent design of the Volvo C-Series compactors. For easy service, the industry-leading swing-up hood provides complete access to the engine and hydraulic components, and a single key accesses service hatches. To maximize uptime, fuses and relays are grouped together, and the water tank can be filled from ground level.

Unequaled compaction

BIG PROJECTS, BIG PERFORMANCE

Ensure high quality compaction with the advanced drum vibration system.

Drive your costs down

Maximize fuel efficiency with adaptive power, auto-idle and auto-engine shutdown without compromising performance.

Target compaction

Ensure you always vibrate at the appropriate rolling speed with Volvo's Impact Spacing Meter, for a smooth, uniform finish.

Roll with the experts

Rely on Volvo's engineering excellence to help protect your business and profits from the ground up.

INTELLIGENT COMPACTION

Maintain consistency and achieve density targets with the intelligently designed Compact Assist, only from Volvo.

More work, fewer passes

Do more work in fewer passes and achieve target density with the high centrifugal force and the 8 amplitude option.





Unobstructed visibility

Work efficiently with a 360° view of the drum, spray bars and jobsite, optimizing rolling precision and safety.

Comfortably productive

Boost productivity and comfort with a rotating seat, ergonomic controls, and noise and vibration isolation.

Machine monitoring made easy

Remotely track machine productivity with CareTrack, ensuring maximum uptime.

New mode of regeneration

Passive regeneration functions automatically during operation without operator input or effect on performance.

EASY MAINTENANCE

Optimize efficiency with the swing-up hood for complete access to the engine and hydraulic components.

Productivity on tap

Optimize productivity with automatic water burst mode and flow-rate calibration to prevent material pick-up.

Specifications

Model			DD120C		DD140C	
Machine weights			with open ROPS/FOPS canopy			
Operating weight ¹	kg	lb	12,565	27,700	13,828	30,486
Weight @ front drum	kg	lb	6,684	14,735	7,328	16,156
Weight @ rear drum	kg	lb	5,881	12,965	6,500	14,330
Shipping weight ²	kg	lb	11,791	25,994	13,043	28,755
Drums						
Width	mm	in	2,000	79	2,135	84
Diameter	mm	in	1,400	55	1,400	55
Shell thickness	mm	in	20	0.79	20	0.79
Finish	Machined surface; chamfered and radiused edges					
Propulsion						
Type	Closed-loop hydrostatic, parallel circuit to both drums					
Drum drive	2-speed axial piston motors with planetary gear drive					
Travel speed	km/h	mph	7.8-12.2	4.8-7.6	7.8-12.2	4.8-7.6
Engine						
Make / model	Volvo D4, EPA Tier 4 final					
Engine type	4 Cyl, Electronic, Turbo charged CAC, EGR, DPF, SCR					
Rated power @ installed speed	kW	hp	110kW @ 2,200 rpm	148 hp @ 2,200 rpm	110kW @ 2,200 rpm	148 hp @ 2,200 rpm
Electrical	24 V DC, 120 A alternator, Starter 5.5 kW, Battery 785 CCA (SAE)					
Brakes						
Service	Dynamic hydrostatic through propulsion system					
Parking secondary	Spring-applied, hydraulic release on both drum drives					
Water system						
Type	Pressure spray drum wetting system with dual water tanks					
Nozzles	Hand-serviceable spray nozzles, 10 per spray bar			Hand-serviceable spray nozzles, 12 per spray bar		
Filtration	Strainer at fill necks, primary filter at each pump, fine filter for each nozzle					
Drum wipers	Front and rear styrene wipers for each drum					
Water tank capacity	l	gal	1,280	338	1,280	338
Miscellaneous						
Articulation angle			+ / - 40°	+ / - 40°	+ / - 35°	+ / - 35°
Oscillation angle			+ / - 10°	+ / - 10°	+ / - 10°	+ / - 10°
Inside turning radius (to drum edge)	mm	in	3,772	149	4,562	180
Fuel tank capacity	l	gal	199.8	52.8	219.9	58.1
DEF tank capacity	l	gal	20	5.28	20	5.28
Hydraulic oil capacity	l	gal	149.9	39.6	149.9	39.6
Gradeability (theoretical)			33%	33%	29%	29%

1 incl. 50% fuel, 50% water, full hyd., 75 kg / 165 lb operator

2 incl. 50% fuel, no water, no operator

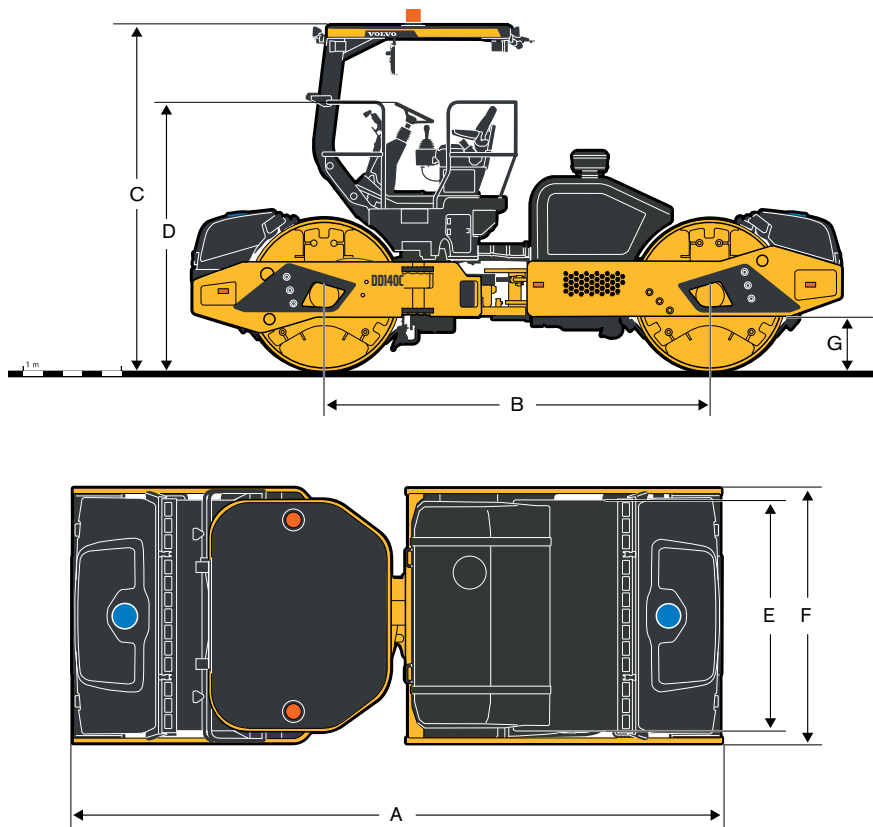

DIMENSIONS

	DD120C		DD140C	
	with open ROPS/FOPS canopy			
	mm	in	mm	in
A	5,973	235.2	5,973	235.2
B	3,550	139.8	3,550	139.8
C	3,177	125.1	3,177	125.1
D	2,479	97.6	2,479	97.6
E	2,000	79.0	2,135	84.0
F	2,218	87.3	2,350	92.5
G	505	19.9	505	19.9

Amplitude Setting	DD120C						DD140C					
	Nominal amplitude		Vibration frequency		Eccentric force		Nominal amplitude		Vibration frequency		Eccentric force	
	mm	in	Hz	VPM	kN	lbf	mm	in	Hz	VPM	kN	lb
2 amplitudes												
High Amplitude (Low frequency)	0.89	0.0349	50	3,000	187	42,070	0.88	0.0346	45	2,700	186	41,720
Low Amplitude (High frequency)	0.36	0.014	66.7	4,000	134	30,020	0.35	0.0139	66.7	4,000	163	36,680
8 amplitudes												
1	0.38	0.0149	56.7	3,400	102.2	22,980	0.33	0.0129	53.3	3,200	97.0	21,810
2	0.40	0.0157	56.7	3,400	108.2	24,330	0.35	0.0137	53.3	3,200	103.4	23,240
3	0.46	0.018	56.7	3,400	123.6	27,780	0.40	0.0159	53.3	3,200	119.4	26,850
4	0.53	0.0208	56.7	3,400	142.8	32,110	0.47	0.0185	53.3	3,200	139.4	31,340
5	0.60	0.0235	56.7	3,400	161.5	36,310	0.54	0.0211	53.3	3,200	158.6	35,660
6	0.65	0.0257	56.7	3,400	176.7	39,720	0.59	0.0231	53.3	3,200	174.1	39,150
7	0.69	0.0271	56.7	3,400	186.5	41,920	0.62	0.0245	53.3	3,200	184.1	41,400
8	0.70	0.0276	56.7	3,400	189.8	42,680	0.63	0.0249	53.3	3,200	187.6	42,170

Equipment

STANDARD EQUIPMENT		
	DD120C	DD140C
Engine		
Battery disconnect switch	•	•
V-belt protection	•	•
Operator environment		
Open ROPS/FOPS canopy	•	•
Operator seat, steering wheel and main controls: rotating +/- 90°	•	•
Propulsion control lever	•	•
Adjustable steering wheel	•	•
2 charger sockets 12V	•	•
Anti-slip cab floor, easy to clean	•	•
Cup holder	•	•
Seat switch with timer delay	•	•
Three-point seat belt	•	•
Seat belt alarm	•	•
Vibration and drum system		
Auto vibration	•	•
Selectable vibration: front, rear, both	•	•
2 frequencies, 2 amplitudes	•	•
Electrics and electronics		
4 Halogen work lights in frame (2 on each bumper)	•	•
Permanent wetting system water level display	•	•
Permanent fuel level display	•	•
Information display:	•	•
- Fluid temperatures	•	•
- Engine speed	•	•
- Vehicle speed	•	•
Impact meter	•	•
Emergency stop button	•	•
Back-up alarm	•	•
Water system		
Two spray bars per drum	•	•

OPTIONAL EQUIPMENT		
	DD120C	DD140C
Vibration and drum system		
8 amplitudes	•	•
Electrics and electronics		
4 Xenon canopy, 2 LED drum surface, 4 LED drum edge, 4 frame Halogen, 2 step lights	•	•
4 Xenon canopy, 2 LED drum surface, 4 LED drum edge, 4 frame Xenon, 2 step lights	•	•
4 frame Halogen lights	•	•
Rotating beacon	•	•
Intelligent Compaction	•	•
Intelligent Compaction with Density Direct	•	•
CareTrack	•	•
Caretrack Anti-theft	•	•
Asphalt temperature gauge kit	•	•
Structure		
Special paintwork	•	•
Biodegradable hydraulic oil	•	•

SELECTION OF VOLVO OPTIONAL EQUIPMENT

Air pre-cleaner



HID lights and strobe



Eight-amplitude



Auto-idle / Auto-engine shutdown



Quick drain freeze prevention

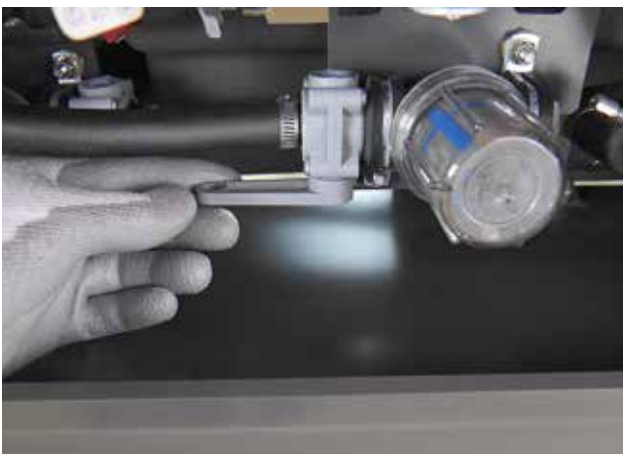

Not all products are available in all markets. Under our policy of continuous improvement, we reserve the right to change specifications and design without prior notice. The illustrations do not necessarily show the standard version of the machine.

VOLVO

Volvo Construction Equipment

www.volvoce.com