

Volvo Construction Equipment
Building Tomorrow



DD145

Volvo Double Drum Compactors 14.1 t 165 hp



WELCOME TO OUR WORLD

Welcome to a world of industry leading machinery. A world where imagination, hard work and technological innovation will lead the way towards developing a future which is cleaner, smarter, and more connected. A world supported by the enduring values of the Volvo Group. A world of stability, sustainability and innovation. A world which we put our customers at the heart of.

Welcome to the world of Volvo Construction Equipment – we think you're going to like it here.

The road to success

Our range of road machinery combines the heritage of the Ingersoll Rand and ABG brands with the engineering excellence of Volvo. The result is a line-up of Volvo pavers and compactors which achieve an unrivalled level of quality, in both paving and compaction applications.

Building on our proud history, we continue to innovate our products to offer customers the best solutions for their operation. Our Compact Assist and Pave Assist products are just two examples of how we are developing intelligent solutions to ensure our machines deliver world-class performance and results long into the future.



Solutions for you

Our industry leading machines are just the start of your relationship with Volvo. As your partner, we have developed an extensive range of additional solutions to help you improve uptime, boost productivity and reduce costs.

Designed for your business

Structured across nine blocks, our portfolio of products and services are designed to complement your machine's performance and boost your profitability. Simply put, we offer some of the best guarantees, warranties and technological solutions in the industry today.

There when you need us

Whether you're buying new or used, our global network of dealers and technicians offer around-the-clock support, including machine monitoring and world-class parts availability. It's the basis of everything offered by Volvo Services, so you can be confident we've got you covered right from the start.

BUILDING TOMORROW

The ultimate roller

GET THE JOB DONE

- Compact close to obstacles with the leg-style, pedestal frame design
- Roll along curve and edges thanks to articulation joint with offset feature
- Powerful vibration system
- 2,135mm wide drums with large diameter for added smoothness
- Impact Spacing Meter display

EFFICIENT DRUM WETTING

- Automatic drum wetting system
- Uniform drum coverage
- Backup water pump
- Inside and outside drum wipers

TOP PERFORMING VOLVO ENGINE

- Fuel efficient and reliable
- One-stop-shop for maintenance

OPERATE WITH EASE

- Easy to reach, ergonomic controls
- Backlit multifunction display and keypad
- Rotating console
- All-around visibility





SAFETY AS STANDARD

- Easy platform access: three-point contact
- Anti-slip plates
- High visibility handrails
- Operator presence switch

SIMPLE SERVICING

- Swing up hood
- Remote drains
- Ground level access to grouped filters
- 3,000hr eccentric bearings oil change interval
- 2,000hr hydraulic oil change interval
- Grouped fuses and relays

VOLVO SERVICES: BOOST UPTIME

- New Pulse telematics system
- Volvo Active Care: 24/7 machine monitoring
- Genuine Volvo Parts

Specifications

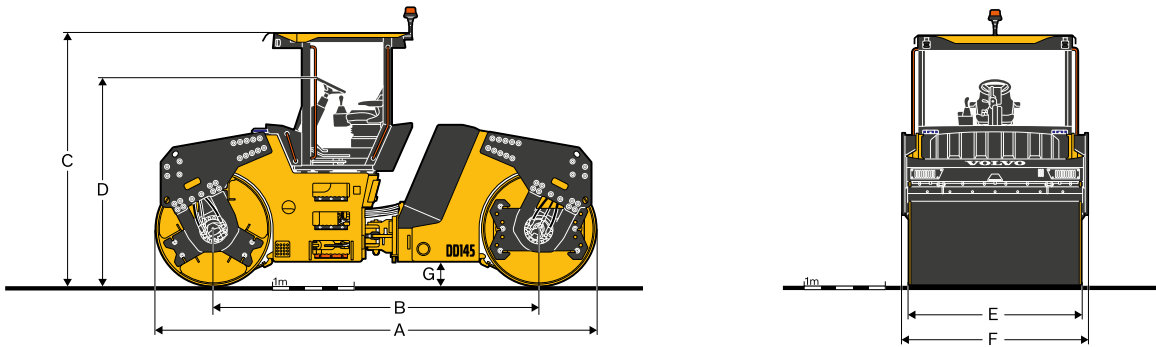

Model			DD145		
Machine weights					
Operating weight ¹	kg	lb	14 103	31,090	
Weight @ front drum	kg	lb	7 081	15,610	
Weight @ rear drum	kg	lb	7 022	15,480	
Shipping weight ²	kg	lb	13 600	29,981	
Drums					
Width	mm	in	2 135	84	
Diameter	mm	in	1 400	55	
Shell thickness	mm	in	22	0.87	
Finish	Surface Class 3, STD 120-0015				
Propulsion					
Type	Closed-loop hydrostatic, parallel circuit to both drums				
Drum drive	2-speed axial piston motors with gearbox drive				
Travel speed	km/h	mph	0 - 12	0 - 7.4	
Engine					
Make / model	Volvo/Deutz D5E				
Engine type	4 Cyl, Electric, Turbo charged, air cooler Charged				
Rated power @ 2 000 r/min	kW	hp	123	165	
Electrical	24V				
Brakes					
Service	Hydrostatic				
Parking secondary	Spring Applied, Hydraulic Released				
Water system					
Type	3 level filtration, diaphragm pressure pump				
Nozzles	Hand-serviceable quick fit spray nozzles, 8 per spray bar				
Filtration	Three-stage filtration system				
Drum wipers	4 wipers, 2 on each drum				
Water tank capacity	l	gal	860	227	
Miscellaneous					
Articulation angle			+ / - 32°	+ / - 32°	
Oscillation angle			+ / - 7.5°	+ / - 7.5°	
Inside turning radius (to drum edge)	mm	in	5 085	200	
Fuel tank capacity	l	gal	220	58	
Hydraulic oil capacity	l	gal	80	21	
Gradeability (theoretical)			35%		

¹ incl. 50% fuel, 50% water, full hyd., 75 kg / 165 lb operator

² incl. 50% fuel, no water, no operator

DIMENSIONS	DD145	
	mm	in
A	5 380	211.8
B	3 980	156.7
C	3 175	125
D	2 513	98.9
E	2 135	84.1
F	2 312	91
G	300	11.8

	AMPLITUDE SETTING					
	DD145					
	Nominal amplitude		Vibration frequency		Eccentric force	
	mm	in	Hz	VPM	kN	lbf
1	0.88	0.03	45	2,700	186	41,857
2	0.35	0.01	52	3,120	103	23,179

Equipment

STANDARD EQUIPMENT

Engine

Battery disconnect switch
V-belt protection

Operator environment

Open canopy
Operator seat w/adj back, steering wheel and main controls: rotating +/- 90°
Propulsion control lever
Adjustable steering wheel
1 charger socket 12V
Anti-slip cab floor, easy to clean
Cup holder
Seat switch with timer delay

Vibration and drum system

Auto vibration
Selectable vibration: front, rear, both
2 amplitudes 2 frequency

Electrics and electronics

4 LED work lights in frame (2 on each bumper)
4 LED work lights in canopy (2 for front, 2 for rear)
Permanent wetting system water level display
Permanent fuel level display
Information display:
- Fluid temperatures
- Engine speed
- Vehicle speed
Emergency stop button

Water system

One spray bar per drum

OPTIONAL EQUIPMENT

Electrics and electronics

LED Strobe light

Others

Offset

VOLVO

Volvo Construction Equipment

volvoce.com