

Volvo Construction Equipment
Building Tomorrow



CR30B, CR35B

Volvo Combination Rollers 2.7-3.0 t / 6,005-6,515 lb 49.6 hp



A passion for performance

At Volvo Construction Equipment, we're not just coming along for the ride. Developing products and services that raise productivity – we are confident we can lower costs and increase profits for customers around the globe. Part of the Volvo Group, we are passionate about innovative solutions to help you work smarter – not harder.

Helping you to do more

Doing more with less is a trademark of Volvo Construction Equipment. High productivity has long been married to low energy consumption, ease of use and durability. When it comes to lowering life-cycle costs, Volvo is in a class of its own.

Designed to fit your needs

There is a lot riding on creating solutions that are suited to the particular needs of different industry applications. Innovation often involves high technology – but it doesn't always have to. Some of our best ideas have been simple, based on a clear and deep understanding of our customers' working lives.



You learn a lot in 180 years

Over the years, Volvo has advanced solutions that have revolutionized the use of construction equipment. No other name speaks Safety louder than Volvo. Protecting operators, those around them and minimizing our environmental impact are traditional values that continue to shape our product design philosophy.

We're on your side

We back the Volvo brand with the best people. Volvo is truly a global enterprise, one that is on standby to support customers quickly and efficiently – wherever they are.

We have a passion for performance.

A strong, dedicated, capable dealer network

Our dealers are strategically located throughout North America to provide the equipment you need and the parts and service support you demand for a productive and profitable operation.

The strength of our dealer network is enhanced with extensive individualized product support training at our best-in-class Customer Center in Shippensburg and through hands-on training. Using a great Product Demonstration Center featuring a dedicated area for most common applications, visitors operate equipment from our entire product line under a variety of simulated working conditions. This facility is in year-round use by our dealers and customers.

Building the best starts right here.

The products designed and manufactured by Volvo Construction Equipment have their beginnings at the most advanced Research & Design centers in the industry. Volvo CE machines are designed in 11 R&D centers and produced in 15 manufacturing facilities across the world.

The major R&D center and manufacturing plant in the Americas is located in Shippensburg, Pennsylvania. This facility has been in operation for over 30 years and – with its recently added 200,000 sq. ft. expansion – now covers 570,000 sq. ft. on an 80 acre campus. Dedicated work teams and highly advanced technologies and techniques using the Volvo Production System ensure continuous quality improvements, labor savings and cost control to reach the high quality that our customers have come to expect from Volvo.





Volvo Trucks



Renault Trucks



Mack Trucks



UD Trucks



Volvo Buses



Volvo Construction Equipment



Volvo Penta



Volvo Financial Services

Compact machine, big performance

Intuitive operation

Consistent with other Volvo T4F compactors, the easy-to-use side console enables you to fine-tune adjustments while compaction is underway.

SEAL THE MAT

The four rear-mounted pneumatic tires manipulate the compacted material to improve surface texture and reduce water intrusion

All angles in view

Roll worry-free with an optimally positioned sliding seat and sloping engine hood design, offering 360° visibility.

PRODUCTIVITY ON TAP

The rustproof, pressurized water system provides full coverage to the drum surface to prevent asphalt pick-up, while the emulsion system prevent material pick-up on the tires.

Consistent compaction

Prevent over-compaction with the auto-vibration system, which automatically engages vibration when the machine reaches approximately 2.4 km/h (1.5 mi/h), and disengages when the speed drops below 1.9 km/h (1.2 mi/h).





POWER TO PERFORM

The new Tier 4 Final-compliant engine delivers high performance, without the need to stop for regeneration.

Transportability

For ease of transportation, the foldable ROPS option can be easily collapsed without the need for special tools.

Roll with the experts

Built on decades of engineering excellence, the machined drums produce a smooth, mark-free mat thanks to their chamfered and rounded edges.

Comfortable and convenient

Stay comfortable in the updated operator's platform, offering a conveniently located cup holder and power port.

Simple serviceability

For ease of maintenance, the hinged engine hood tilts forward, providing ground-level access to the engine and hydraulic components.

Drive your costs down

Cut fuel consumption with the auto-idle option, which reduces the engine speed when controls are inactive for over sixty seconds.

Specifications

Model			CR30B		CR35B	
Machine weights (w/ ROPS)						
Operating weight	kg	lb	2,724	6,005	2,961	6,515
Weight @ front drum	kg	lb	1,417	3,125	1,518	3,340
Weight @ rear tires	kg	lb	1,306	2,880	1,443	3,175
Shipping weight	kg	lb	2,477	5,460	2,714	5,970
Drum						
Width	mm	in	1,200	47.2	1,320	52.0
Diameter	mm	in	732	28.8	736	29
Shell thickness	mm	in	12	0.5	14	0.55
Finish	Machined, chamfered edge					
Tires						
Number			4		4	
Size	mm	in	190.5 X 381 12PR	7.5" X 15" 12 PR	190.5 X 381 12PR	7.5" X 15" 12 PR
Tire Load	kN	lb	3.2	720	3.5	794
Tire wipers	Steel Scraper			Steel Scraper		
Vibration						
Frequency	Hz	vpm	69	4,140	69	4,140
Nominal amplitude	mm	in	0.43	0.02	0.37	0.015
Centrifugal force	kN	lb	33.9	7,615	35.8	8,050
Propulsion						
Type	Closed-loop, hydrostatic, parallel circuit			Closed-loop, hydrostatic, parallel circuit		
Drum drive	Pump: axial piston; Motor: radial piston, low speed, high torque					
Travel speed	km/h	mi/h	0 - 11.8	0 - 7.3	0 - 11.8	0 - 7.3
Engine						
Make / model	Kubota D1803-CR-TE4B					
Engine type	3-cylinder diesel					
Rated power @ 2,700 r/min	kW	hp	37	49.6	37	49.6
Electrical	12 volts DC, negative ground; 60 A alternator					
Brakes						
Service	Dynamic hydrostatic through propulsion system					
Parking secondary	Spring-applied, hydraulically released (SAHR)					
Water system						
Type	Pressurized					
Nozzles	5 hand servicable at drum, 1 per tire (4)					
Filtration	80 mesh in-line with 100 mesh @ nozzles					
Drum wipers	Spring-loaded, self-adjusting, rubber wipers					
Water tank capacity	l	gal	299	79	299	79
Miscellaneous						
Articulation angle			+ / - 30°			
Oscillation angle			+ / - 10°			
Inside turning radius (to drum edge)	mm	in	2,648	104.3	2,587	101.9
Fuel tank capacity	l	gal	66	17.4	66	17.4
Hydraulic oil capacity	l	gal	85	22.4	85	22.4
Emulsion capacity	l	gal	20.4	5.4	20.4	5.4
Gradeability (theoretical)			45		41	
Guaranteed Sound Level						
Operator's Ear, acc. to ISO 11203:2009	LpA dB(A)		89		87	
External, acc. to Directive 2000/14/EC	LwA dB(A)		106		104	

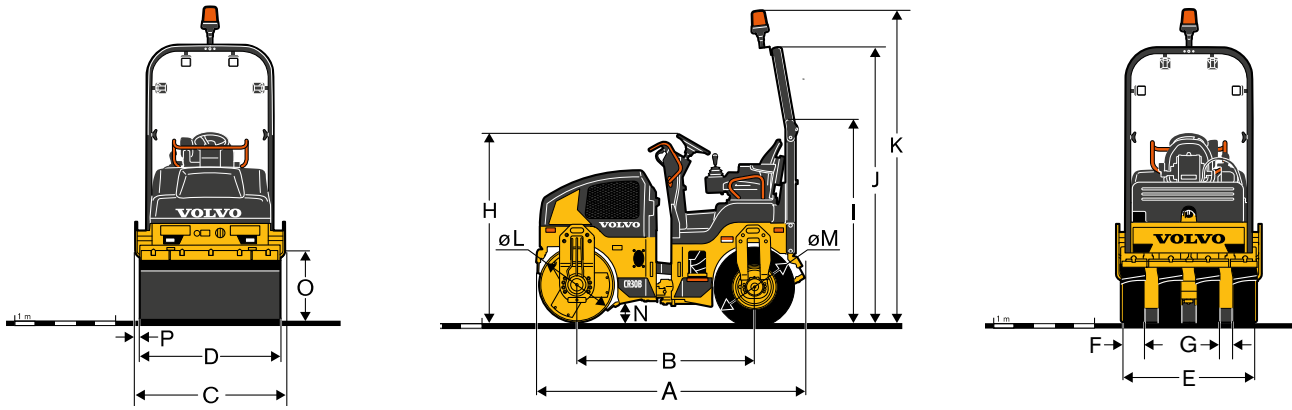

Dimensions	CR30B		CR35B	
	mm	in	mm	in
A	2,614	102.9	2,614	102.9
B	1,742	68.6	1,742	68.6
C	1,303	51.3	1,435	56.5
D	1,200	47.2	1,320	52.0
E	1,150	45.3	1,300	51.2
F	213	8.4	213	8.4
G	83	3.3	141	5.6
H	1,842	72.5	1,842	72.5
I	1,991	78.4	1,991	78.4
J	2,725	107.3	2,725	107.3
K	2,980	117.3	2,980	117.3
L	732	28.8	736	29.0
M	775	30.5	775	30.5
N	185	7.3	185	7.3
O	445	17.5	445	17.5
P	61	2.4	61	2.4

Equipment

STANDARD EQUIPMENT

	CR30B	CR35B
Engine		
Battery Disconnect Switch	•	•
US EPA T4F compliant engine	•	•
Operator environment		
Open ROPS	•	•
Sliding operator seat	•	•
Seat switch with timer delay	•	•
Cup holder	•	•
Anti-slip floor	•	•
Seat belt	•	•
Seat belt alarm	•	•
12 volt power point	•	•
Vibration and drum system		
Single speed vibration	•	•
Electrics and electronics		
Easily accessible fuses and relays	•	•
Permanent fuel level display	•	•
Permanent water level indicator	•	•
Information display:	•	•
-Fluid temperatures	•	•
-Engine speed	•	•
-Vehicle speed	•	•
Emergency stop button	•	•
Other		
Hand servicable spray nozzles	•	•
Adjustable spray flow rate	•	•
"Racetack" maintenance decal	•	•

OPTIONAL EQUIPMENT

	CR30B	CR35B
Engine		
Auto Idle	•	•
Operator environment		
Foldable arch-ROPS	•	•
Open ROPS/FOPS canopy	•	•
Mirror	•	•
Steering knob	•	•
Vandal cover	•	•
Electrics and electronics		
Work lights	•	•
Work lights in frame	•	•
Roading lights	•	•
Strobe lights	•	•
Rotating Beacon	•	•
Backup alarm	•	•
Anti-theft	•	•
Engine oil pressure display	•	•
Caretrack	•	•
Water system		
Cocoa mats installation	•	•
Water Strainer	•	•
Other		
Lifetime Frame Guarantee	•	•
Bio-degradable oil	•	•
Special Paint	•	•
Hydraulic test ports	•	•
ROPS ship loose	•	•
License Plate	•	•

VOLVO

Volvo Construction Equipment

www.volvoce.com