



Volvo Construction Equipment

# MCT110D, MCT125D, MCT135D

Volvo Compact Track Loaders ROC: 1 021-1 361 kg 74.8-93.3 hp



# Primed for performance

Move more for less in all seasons and terrains with the powerful and durable Volvo D-Series compact track loader, equipped with heavy-duty components and increased strength to maximize uptime and profitability. Delivering superior loading performance and durability, the D-Series offers improved visibility, safety, serviceability and enhanced access of a side-entry machine thanks to the unique single loader arm design.

## See more, do more

See and do even more thanks to the curved single loader arm, large top window and narrow ROPS cab pillars, offering 270° of visibility – 60% more than any other compact track loader on the market. The robust arm and attachment bracket are better than ever, providing superb forward and side views of the attachment and jobsite. The cab's design also features glass panels and a rearview mirror, optimizing productivity and safety.



## Designed to perform

Do more with the Volvo D-Series, equipped with the next generation single loader arm design, providing more strength and durability even in the harshest working conditions. Built with 20% more steel than conventional compact track loaders, the heavy-duty design and reinforcement of the single loader arm provide reliability and effectively distribute the load, boosting productivity and the profitability of your business.



## Simplified service

With simple serviceability, the Volvo D-Series takes the hassle out of daily checks and helps maximize your profitability. All service and maintenance points are arranged in a simple layout and can be accessed using the large rear door. Gain easy access to internal components with the forward-tilting cab which can be moved by one person without needing to raise the arm.



## Biggest cab in the industry

Take on tough tasks from the comfort of the industry's largest cab, boasting 30% more room than standard compact track loaders. The climate-controlled ROPS/FOPS high spec Volvo cab offers ample storage and legroom as well as noise insulation, keeping the operator fresh, alert and focused – longer. From the adjustable seat, access logically grouped controls and easy-to-read gauges located in the two ergonomic consoles.





# TOTAL ACCESS

Say hello to the safest and most convenient cab access on the market. Designed with the operator in mind, the Volvo cab ensures safe ingress and egress regardless of terrain. The large side door and non-slip step eliminate the risk of injury from climbing over cumbersome attachments as well as the need to turn to sit down, optimizing safety and usability.



# ULTIMATE TOOL CARRIER

Even in demanding environments, no job is too tough for the robust Volvo D-Series compact track loader. Built with high quality components, this machine is the ultimate tool carrier, offering unparalleled versatility to ensure long-lasting performance across any applications or conditions. Tailor the machine to match the exact requirements of your jobsite.

# More than a machine

With a Volvo compact track loader and a Volvo attachment, you simply get more done. Choose from Volvo's extensive range of attachments and customer solutions, tailored to your business and operations to get the most out of your investment. Ensure your machine achieves ultimate uptime with our unique, global dealer support network, designed to generate maximum profit and growth for your business.

## Attach and attack

From hauling earth to breaking concrete, rely on Volvo attachments to get the job done. Choose from an extensive range of attachments, purpose-built to work in harmony with all Volvo compact track loaders. With functions and properties perfectly matched, Volvo attachments are an integrated part of the machine, delivering maximum productivity.



## Strongest attachment bracket

Experience superior versatility and efficiency with the industry's strongest attachment bracket. Along with the tilt cylinder, located inside the arm, the attachment bracket is protected to ensure ultimate uptime. A visual indicator on the attachment bracket lets the operator know when the attachment is locked, significantly improving safety.



## Keep your Volvo a Volvo

We're committed to providing a complete solution to guarantee the highest performance of your Volvo machine, including high quality attachments and Genuine Volvo Parts, extensively tested and approved because every part is vital for performance. Rely on our leading parts availability to ensure maximum uptime, extend the life of your Volvo and optimize the profitability of your business.



## One stop shop

Get exactly what you need from your local dealer, who will provide all the service and support of your Volvo machine, parts and more, giving you peace of mind knowing Volvo has you – and your machine – covered. Volvo offers long-term partnerships, protects your revenue and provides a full range of customer solutions using high quality parts and excellent services – available all in one place.



# Complete package

## Radial and vertical lift

Choose a vertical lift model for loading and material handling applications, or radial lift for ground engaging applications.

## Parallel-Lift, raise

Hydraulic parallel-lift allows the attachment to remain parallel to the ground throughout the raise cycle.

## ULTIMATE TOOL CARRIER

Pick up and run with multiple attachments to take on a variety of jobs with just one machine.

## Strongest attachment bracket

Experience superb versatility and efficiency with the durably-protected attachment bracket, designed to boost productivity.

## Single lever attachment bracket

The new mechanical attachment bracket is easily operated with one lever only.

## Quick attachment changes

The hydraulic quick couplings, including the standard case drain, feature pressure relief valve for easy attachment change.

## Attach and attack

Choose from an extensive range of attachments, purpose-built to work in harmony with all Volvo compact track loaders.





**See more, do more**

Boost productivity with 270° of visibility provided by the curved single loader arm, large top window and narrow cab pillars.

**Designed to perform**

Do more with the next generation single loader arm design, providing greater strength and durability than ever before.

**Biggest cab in the industry**

Stay fresh, alert and focused in the spacious Volvo cab, providing all the room you need to power through the day.

**TOTAL ACCESS**

The large side door and non-slip step ensure safe and easy access, eliminating the need to climb over attachments.

**Simplified service**

Access daily maintenance points via the large rear door. Tilt the cab forward without raising the arm for in-depth service.

# Specifications

		MCT110D	MCT125D	MCT135D
<b>Engine</b>				
Model		TC-55	TC-55	TC-68
Cylinders		4	4	4
Fuel type		Diesel	Diesel	Diesel
Displacement	cm <sup>3</sup>	4 399	4 399	4 399
Aspiration		Turbo	Turbo	Turbo
Cooling system		Water	Water	Water
<b>Horsepower</b>				
SAE gross power	kW	55	55	68.6
	hp	74.8	74.8	93.3
Max. net power	kW	54.1	54.1	67.7
	hp	73.6	73.6	92
at engine speed	r/min	2 400	2 400	2 400
Max. gross torque	Nm	327	327	408
at engine speed	r/min	1 800	1 800	1 800
Max. no load speed	r/min	2 300	2 300	2 300
<b>Electrical system</b>				
Battery	V/Ah	12/109	12/109	12/109
Alternator	Ah	95	95	95
Starter	kW	2	2	2
<b>Drivetrain</b>				
Tracks	mm	400	400	400
Gound pressure with standard tracks	kPa	27.6	29.0	29.6
Tracks optional	mm	450	450	450
Gound pressure with optional tracks	kPa	24.8	25.5	26.2
<b>Hydraulics system-loader</b>				
Std hydraulic pump output	l/min	90	90	90
High flow pump output	l/min	125	125	125
at engine speed	r/min	2 300	2 300	2 300
System pressure	MPa	23	23	23
<b>Service capacities</b>				
Cooling system	l	22	22	22
Engine crankcase with filter, change	l	15	15	15
Fuel tank	l	103.3	103.3	103.3
Hydraulic system - total capacity	l	55	55	55
Hydraulic reservoir capacity	l	26	26	26
<b>Performance</b>				
Lift arm path		Radial	Vertical	Vertical
Rated operating capacity at 35% (ISO 14397)	kg	1 021	1 179	1 361
Rated operating capacity at 50%	kg	1 751	1 812	1 956
Tipping capacity (ISO 14397)	kg	3 502	3 624	3 913
Operating weight (ISO 6016)	kg	4 746	4 959	5 038
Breakout force, lift	kg	2 528	2 634	2 634
Breakout force, curl	kg	2 968	2 968	2 968
<b>Maximum travel speed</b>				
Single speed	km/h	9.2	9.2	9.2
Two speed	km/h	7.7 / 12.6	7.7 / 12.6	7.7 / 12.6
<b>Cycle time</b>				
Raise (lifting)	s	3.7	3.7	3.7
Lower (power down)	s	2.5	2.5	2.5
Curl	s	1.8	1.8	1.8
Dump	s	2.1	2.1	2.1
<b>Cab</b>				
Refrigerant of type R134a is used when the machine is equipped with air conditioning. Contains fluorinated greenhouse gas R134a, Global Warming Potential 1.430 t CO <sub>2</sub> -eq.				
<b>Sound level</b>				
Driver's ear, according to ISO 6396 / ISO 11201 (Cabin / Canopy)				
LpA	dB(A)	78 / 86	78 / 86	78 / 86
External, according to ISO 6395 / Directive 2000/14/EC				
LwA	dB(A)	101	101	101



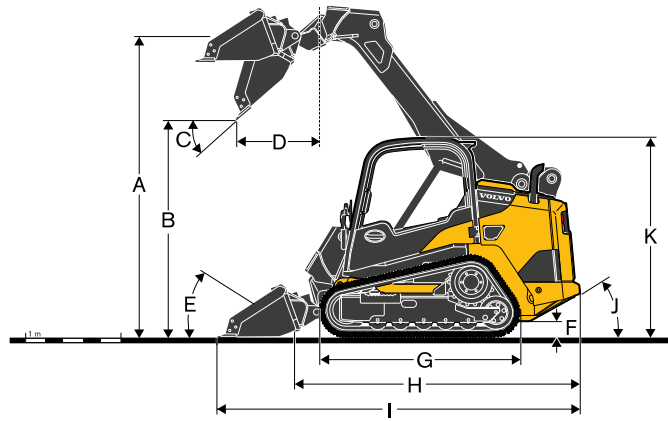
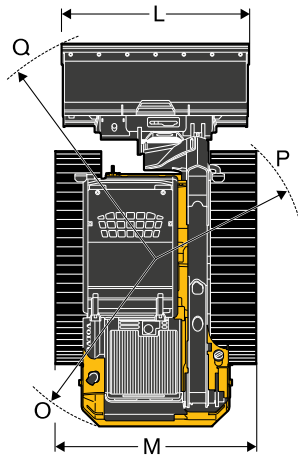

	Units	MCT110D	MCT125D	MCT135D
A	Height to hinge pin	mm	3 180	3 180
B	Dump height	mm	2 280	2 280
C	Dump angle	°	42	42
D	Dump reach	mm	600	900
E	Roll back angle	°	30	30
F	Ground clearance	mm	230	230
G	Trackbase	mm	2 100	2 100
H	Overall length (L/bucket)	mm	3 000	3 000
I	Overall length (W/bucket)	mm	3 800	3 800
J	Angle of departure	°	29	29
K	Overall height	mm	2 080	2 080
L	Bucket width	mm	1 980	1 980
M	Over tracks width (L/bucket)	mm	1 900	1 900
O	Turning radius rear	mm	1 760	1 760
P	Turning radius front L/bucket	mm	1 700	1 700
Q	Turning radius front W/bucket	mm	2 300	2 300

Pallet forks		Overall height	Overall width	Overall length	Adjustable tine spacing		Pallet fork rating	Overall weight
		mm	mm	mm	mm	mm	kg	kg
MCT110D	PF-42	984	1194	1313	229	1143	2722	206
MCT125D								
MCT135D	PF-48	984	1194	1466	229	1143	2722	218

Data according to bucket type	Bucket	Width	Length	Height	Weight	Heaped cap
		mm	mm	mm	kg	m <sup>3</sup>
MCT110D	General Purpose Bucket	1 981	800	521	246	0.47
	Landscape Bucket	1 981	953	521	264	0.58
	Multi Purpose Bucket	1 981	953	701	382	0.61

Data according to bucket type	Bucket	Width	Length	Height	Weight	Heaped cap
		mm	mm	mm	kg	m <sup>3</sup>
MCT125D MCT135D	General Purpose Bucket	1 980	800	521	246	0.47
	General Purpose Bucket	2 134	800	521	261	0.50
	Landscape Bucket	1 981	953	521	264	0.58
	Landscape Bucket	2 134	953	521	279	0.63
	Multi Purpose Bucket	1 981	953	701	382	0.61
	Multi Purpose Bucket	2 134	953	701	401	0.66

# Equipment

## STANDARD AND OPTIONAL EQUIPMENT

- = Standard
- = Optional

	MCT110D	MCT125D	MCT135D
<b>Engine</b>			
4-cylinder, liquid-cooled, 16-valve, direct-injection diesel engines	●	●	●
Meets US EPA-Tier 3, EU St3A	—	—	●
Meets US EPA-Tier 4i, EU St3A	●	●	—
Self cleaning, triple stage air cleaner, including built-in pre-cleaner with active scavenging, primary filter and safety element	●	●	●
12-Volt heavy-duty starter	●	●	●
Alternator with internal regulator	●	●	●
Grid heater	●	●	●
Quick cycle engine preheat	●	●	●
High-capacity radiator	●	●	●
Top mounted, hydraulic oil cooler	●	●	●
Spark arrestor muffler	○	○	○
Auto idling	●	●	●
Reversible fan	○	○	○
External pre-cleaner (cyclonic type)	○	○	○
Engine block heater 110V	○	○	○
Engine block heater 240V	○	○	○
<b>Cab, canopy equipment</b>			
Canopy, isolation mounted, FOPS & ROPS, with low left-hand side door	●	●	●
Cabin, isolation mounted, heated fully glazed sealed and pressurized, FOPS & ROPS, washer/wiper and sliding left hand window	○	○	○
Cabin, isolation mounted, Air conditioned/heated fully glazed sealed and pressurized, FOPS & ROPS, washer/wiper and sliding left hand window	○	○	○
Right-hand laminated glass	●	●	●
Cab access step	●	●	●
Top window	●	●	●
In-cab rearview mirror	●	●	●
Interior light	●	●	●
Pod storage area	●	●	●
12-Volt power accessory outlet	●	●	●
Cup holder	●	●	●
Secondary exit through front windshield	●	●	●
Radio with Auxiliary input	○	○	○
In-cab fuse panel	●	●	●
In-cab analog hourmeter	●	●	●
<b>Control panel</b>			
Engine start/stop key switch	●	●	●
Electronic hand throttle	●	●	●
Electric lift and tilt hydraulic lockouts	●	●	●
Park brake switch	●	●	●
Full audible and/or visual warning systems (Charge pressure, Coolant temperature, Hydraulic oil and Engine oil pressure, Air filter restriction, Alternator, Low Fuel Level)	●	●	●
Fuel gauge	●	●	●
Coolant temperature gauge	●	●	●
Hydraulic oil temperature gauge	●	●	●
Hour meter	●	●	●
Keyless start with immobilizer	○	○	○
<b>Controls</b>			
3-way function levers	●	●	●
7-way function levers, with 14-pin connector	○	○	○
ISO hand electro hydraulic controls	●	●	●
Operator modes	●	●	●
Control pattern selection: ISO or H-pattern	○	○	○
Foot throttle	●	●	●

## STANDARD AND OPTIONAL EQUIPMENT

- = Standard
- = Optional

	MCT110D	MCT125D	MCT135D
<b>Seats and seat belts</b>			
Operator seat bar	●	●	●
Mechanical suspension seat	●	●	●
Air suspension seat, heated, vinyl, with adjustable control pods	○	○	○
Air suspension seat, heated, with adjustable control pods, cloth	○	○	○
2" retractable seat belt	●	●	●
3" retractable seat belt	○	○	○
Three points two inches retractable seat belt	○	○	○
Three points three inches retractable seat belt	○	○	○
<b>Lighting and warning</b>			
2 front 50-Watt work lights	●	●	●
1 rear 50-Watt work lights (2 if AC)	●	●	●
Additional (2nd) 50-Watt work light (if no AC)	○	○	○
Rotating beacon	○	○	○
Tall rotating beacon (Italy)	○	○	○
Back-up alarm with rear light	●	●	●
White noise back-up alarm	○	○	○
Road light kit including left and right hand side rear view mirrors	○	○	○
<b>Loader arm and Hydraulic functions</b>			
Radial lift	●	—	—
Vertical lift	—	●	●
Parallel-Lift, raise only	●	●	●
Lift-arm mounted auxiliary hydraulics (Flat face couplers)	●	●	●
Low flow case drain return line	●	●	●
High flow auxiliary hydraulics	○	○	○
Mechanical attachment bracket	●	●	●
Assisted attachment bracket	○	○	○
Boom Suspension System	○	○	○
Float function	●	●	●
Creep speed control	○	○	○
Travel lock kit (Italy)	○	○	○
<b>Driveline, undercarriage</b>			
2 servo-assisted variable displacement piston pumps mounted in tandem	●	●	●
2 fixed displacement high torque motors	●	●	●
2-speed travel	○	○	○
400 mm wide tracks	●	●	●
450 mm wide tracks	○	○	○
Hydraulic park brake	●	●	●
<b>Maintenance</b>			
Lockable rear service door and engine cover	●	●	●
Heavy-duty, maintenance-free battery - 1 000CCA	●	●	●
Master electrical shut-off switch	●	●	●
Lockable fuel cap	●	●	●
Tilting canopy/cab	●	●	●
Lift-arm support strut	●	●	●
Emergency boom lower valve	●	●	●
<b>Segment protection packages</b>			
- FOPS level 2 roof guard	○	○	○
- Front screen guard	○	○	○
- Heavy duty rear bar	○	○	○
- Tilt cylinder guard	○	○	○
- Polycarbonate screen	○	○	○
- Mud guards and fuel cap protection	○	○	○

Contact your local dealer for more info

---

**SELECTION OF VOLVO OPTIONAL EQUIPMENT**

---

**Heated cab with air conditioning**



**Parallel-Lift, raise only**



**High flow auxiliary hydraulics**



**2-speed option**



**Volvo assisted attachment bracket**



**Boom suspension system**



Not all products are available in all markets. Under our policy of continuous improvement, we reserve the right to change specifications and design without prior notice. The illustrations do not necessarily show the standard version of the machine.

**VOLVO**

**Volvo Construction Equipment**

[www.volvoce.com](http://www.volvoce.com)