

Volvo Construction Equipment
Building Tomorrow



A45G

Volvo Articulated Haulers 41 t 476 hp



Pure uptime

Get continuous production with this bigger, durable and superior machine – always available and ready to work. Count on superb reliability thanks to the machine's robust design, easy service access and outstanding Volvo dealer network. Guarantee pure uptime.

Guaranteed durability

Increase your uptime using heavy-duty front and rear frames, hitch and wet disk brakes. Volvo proven durability and the support of extensive warranty options means you never need to worry about getting the job done. Strength and durability are hallmarks of the Volvo articulated hauler.



Fifty years strong

Fifty years and fifty tonnes later, Volvo is the world's leading manufacturer of articulated haulers. We invented the concept and have been developing and building these machines for over 50 years – it has come a long way from its original 10 tonne articulated hauler. With proven success over the years, the machines include innovative technology and the renowned Volvo engine.



Service access

With industry-leading access, servicing your machine is quick and easy. The front grill swings down, opening a service platform with anti-slip steps. The electric hood opens to 90 degrees, allowing full and safe access to the engine compartment.



Volvo dealer network

The exclusive Volvo dealer network is there to support you whenever you need it. Volvo offers a number of services, local knowledge and global experience, including telematics machine monitoring – CareTrack™ and MATRIS™ – as well as superb parts availability.





UPTIME

Get ready to work with the all new A45G . Designed for heavy hauling in severe off-road operation, the machine's long service life, quality, reliability and durability is everything you expect from a Volvo. Hauling is easier and more efficient.



FUEL EFFICIENCY GUARANTEED

The A45G powered by the world-renowned Volvo engine delivers excellent fuel efficiency without compromising on power or performance. With guaranteed fuel efficiency, this machine will increase your profitability and improve your return on investment.

World-renowned efficiency

Improve your efficiency and move more for less. Excellent fuel efficiency, innovative technology and useful operational data tools help to control your maintenance costs and maximize your investment.

Move more for less

The machine is optimized for efficiency featuring higher payload capabilities. Its smart design allows for more capacity while reducing fuel consumption so you can move more for less.



Operational data

Receive valuable data to improve onsite efficiency and save costs. With intelligent systems from Volvo such as MATRIS™, CareTrack™ and the On Board Weighing system, you will optimize your production and minimise your operational costs.



Control your maintenance costs

The range of Customer Support Agreements offer preventive maintenance, total repairs and a number of uptime services. Volvo uses the latest technology to monitor machine operation and status, giving you advice to increase your profitability. By having a Customer Support Agreement you are in control of your service costs.



Volvo dynamic drive

Dynamic and predictive gear selection adapts to operating conditions, for improved comfort and fuel efficiency.



Hit the targets

Hit your targets with the A45G. This machine features 100% off-road performance, proven Volvo technology and increased payload – contributing to sustainable operations, year after year.

Articulated hauler concept

Go where others can't. The articulated hauler concept provides total versatility so you can access the entire jobsite and climb steeper gradients. Work in all seasons, terrains and applications. With body building solutions and different chassis options you can tailor the machine to your jobsite.



The best articulated hauler

The A45G machine delivers unbeatable off-road performance in its class with features including matched Volvo drivetrain, Automatic Traction Control including 100% differential locks, all-terrain bogie, hydro-mechanical steering.



The right speed for the job

Ensure the right speed for your job using the retarders and dynamic Volvo Engine Brake to adapt your speed for maximum productivity and safety.



Load optimization

The optional On Board Weighing System guarantees the optimal load every cycle. This maximizes production, boosts fuel efficiency and reduces machine wear in all site conditions and operations.





THE BEST JUST GOT BIGGER

Bigger means better when loading more tonnes per hour, with an extra two tonne payload you can carry more in one go. The A45G articulated hauler is built to improve your cycle times and productivity.

The ultimate hauler

New dump support system

The new dump support system increases stability and control in tough environments.

Service access

With industry-leading access, servicing your machine is quick and easy.

Fifty years strong

Fifty years and fifty tonnes later, Volvo is the world's leading manufacturer of articulated haulers.



OPERATOR'S CHOICE

Its comfortable cab and ease of operation, even in adverse conditions, makes operators choose this machine.

UPTIME

Designed for heavy hauling in severe off-road operation, its long service life, quality, reliability and durability is everything you expect from a Volvo.

New gradient controls

New hill assist and dynamic Volvo Engine Brake features give you more control over your machine, whether travelling up or down steep gradients.

FUEL EFFICIENCY GUARANTEED

Powered by the world-renowned Volvo engine delivers excellent fuel efficiency without compromising on power or performance.

Guaranteed durability

With body building solutions and different chassis options you can tailor the machine to your jobsite.

Volvo dynamic drive

Gear shifting adapts dynamically to operating conditions, for improved comfort and fuel efficiency.

The best articulated hauler

The ground-breaking A45G is the best articulated hauler on the market and the latest innovation from Volvo.

New econometer

The new econometer helps the operator to control the machine for extra productivity.

THE BEST JUST GOT BIGGER

Move more tonnes per hour and give a 100% in all conditions with an increase two tonne payload.

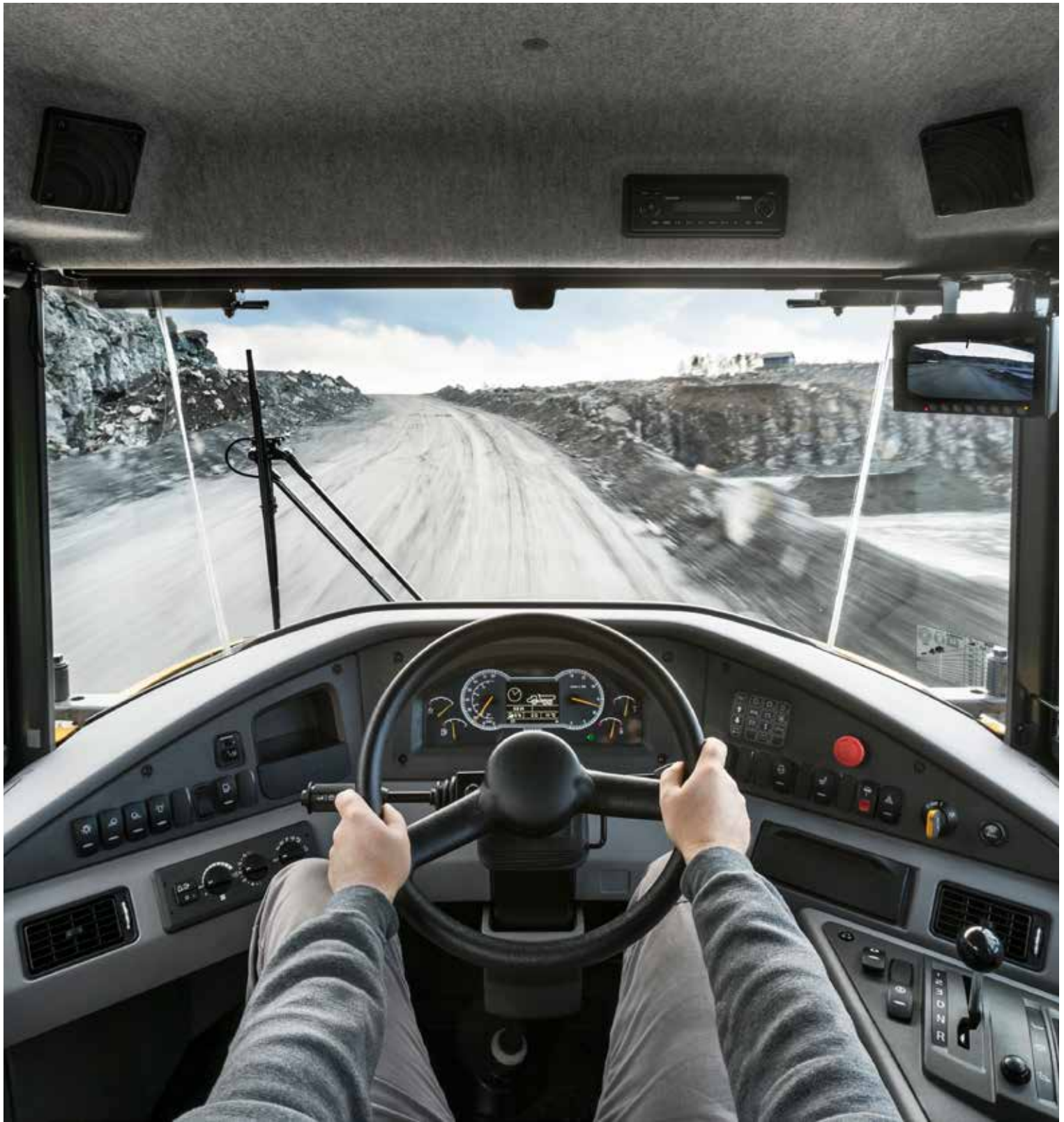

OPERATOR'S CHOICE

When many other machines are onsite, most operators prefer the Volvo. Its comfortable cab and ease of operation, even in adverse conditions, makes operators choose this machine.

Control in comfort

The A45G is the number one operator's choice because of its industry-leading spacious cab and comfortable work environment. Its superior comfort, control, ease of operation and safety appeals to operators, maintaining productivity all day, every day.

Total operator control

The new dump support system, hill assist, dynamic Volvo Engine Brake control and econometer as well as load and dump brake, help the operator control the machine for extra productivity and safety in all conditions.



Ease of operation

The ergonomic, comfortable controls are easy to understand and suit all operators, combined with automatic functions for increased ease of operation.



Operator comfort

Feel comfortable and spend more time in the A45G. The centrally positioned operator, superior steering, excellent suspension, low noise levels, climate control, space and visibility, reduce operator fatigue for more effective operations.



Safety

A number of safety features such as superior visibility and efficient lighting help to keep the operator and people working around the machine safe in the most demanding working environments – whether it's the operator, trainers, mechanics or site workers.



Volvo A45G in detail

Engine

16 liter, 6-cylinder straight Turbocharged diesel engine with 4 valves per cylinder, overhead camshaft and electronically controlled unit injectors. It has wet replaceable cylinder liners and replaceable valve guides and valve seats. The engine has IEGR (Internal Exhaust Gas Recirculation)

Engine model	Volvo	D16E
Max power - SAE J1995 Gross	kW	350
	hp	476
at engine speed	r/min	1 800
Flywheel power - ISO 9249, SAE J1349 Net	kW	347
	hp	472
at engine speed	r/min	1 800
Max torque - SAE J1995 Gross	Nm	2 525
Max torque - ISO 9249, SAE J1349 Net	Nm	2 500
at engine speed	r/min	1 050
Displacement	l	161

Electrical system

All cables, sockets and pins are identified. Cables are enclosed in plastic conduits and secured to main frame. Halogen lights. Prewired for options. Connectors meet IP67 standard for water-proofing as necessary.

Voltage	V	24
Battery	V	2x12
Battery capacity	Ah	2x225
Alternator	kW/A	3.396/120
Starter motor	kW	9

Drivetrain

Torque converter with built-in lock-up function.
Transmission: Fully automatic Volvo PowerTronic planetary transmission with nine forward gears and three reverse gears. The transmission has the ability to skip gears for fast and accurate gear selection.
Dropbox: Volvo-developed, in-line design with high ground clearance and 100% longitudinal "dog clutch" type differential lock.
Axles: Heavy duty, purpose built Volvo design with fully floating axle shafts, planetary type hub reductions and 100% dog clutch type differential lock.
Automatic traction control system (ATC).

Torque converter		2.1:1
Transmission	Volvo	PT 2529
Dropbox	Volvo	IL2 ATC
Axles	Volvo	ARB H40

Suspension

Front suspension: Three point suspension consisting of a stay fitted to the frame structure by a spherical rubber bushing, shock absorbers with accumulators and cross stays.

Brake system

Fully hydraulic, wet multiple disc brakes with enclosed, forced oil-cooled multiple discs on all wheels. Two circuit brake system. Complies with ISO 3450 at total machine weight.
Circuit division: One circuit for front axle and one for bogie axles.
Parking brake: Spring-applied disc brake acting on the trailer unit propeller shaft. When the parking brake is applied, the longitudinal differential locked.
Retarder: Service brake retarder function and Volvo Engine Brake (VEB).

Steering System

Hydro-mechanical articulated steering, self compensating design.
Two double-acting steering cylinders.
Steering angle: 3,4 steering wheel turns lock-to-lock, $\pm 45^\circ$.
Steering system, including secondary steering fulfi lls ISO 5010.

Chassis

Frames: box type, heavy duty. High strength steel, robot welded.
Rotating hitch: 100% maintenance free, fully sealed, with permanently greased tapered roller bearings.

Cab

Mounted on rubber pads. Ergonomically designed. Easy entry and exit. Wide angle forward view.
Operator centrally positioned above the front axle. Adjustable operators seat with retractable seat belt.
Tilt/telescopic steering wheel. Ergonomically positioned controls. Filtered air. Optional climate control system.
Operator communication system: Contronics.
Large color display, user-friendly and easy-to-understand information, all vital machine functions are constantly monitored.
Instructor seat with seat belt.
Safety: ROPS/FOPS standards approved according to ISO3471, SAE J1040 / ISO3449, SAE J231.

Sound level in cab (ISO 6396) - LpA	dB(A)	72
External sound level (ISO 6395) - LwA	dB(A)	112
Internal sound level with sound kit: 70 dB(A)		
External sound level with sound kit: 110 dB(A)		

Hydraulic system

Pumps: Four variable displacement piston pumps driven by the flywheel PTO.
Two load-sensing used for steering and tipping and two electrical controlled used for fan, brake cooling and brake power supply.
One ground-dependent piston pump for secondary steering mounted on the dropbox.
Two return oil filters with magnetic cores provide effective oil filtration.
System max working pressure

System max working pressure	MPa	26
-----------------------------	-----	----

Dumping System

Patented Load and Dump Brake.
Dumping Cylinders: two single stage double acting cylinders.

Tipping angle	°	70
Tipping time with load	s	12
Lowering time	s	10

Body

Plate thickness

Front	mm	8
Sides	mm	11
Bottom	mm	14
Chute	mm	16

Material

Material		HB450 steel
Yield strength	N/mm ²	1 150
Tensile strength	N/mm ²	1 350

Load Capacity

Standard Body		
Load capacity	kg	41 000
Body, struck	m ³	19.7
Body, heaped 2:1	m ³	25.1
With overhung tailgate		
Body, struck	m ³	20.0
Body, heaped 2:1	m ³	26.2

Specifications

REFILL CAPACITIES

Crankcase	l	55
Fuel tank	l	480
Cooling system	l	49
Brake cooling system	l	188
Transmission	l	43
Dropbox	l	9
Axles, front/bogie	l	26/52
Hydraulic tank	l	174

OPERATING WEIGHT UNLOADED

Tires		29.5R25*
Front	kg	16 300
Rear	kg	13 700
Total	kg	30 000
Payload	kg	41 000

Operating weight includes all fluids and operator

*) A45G with tires 875/65R25, add 300 kg /axle

TOTAL WEIGHT

Tires		29.5R25*
Front	kg	20 500
Rear	kg	50 500
Total	kg	71 000

*) A45G with tires 875/65R25, add 300 kg /axle

GROUND PRESSURE

Tires	29.5R25	875/65R25	
Unloaded			
Front	kPa	113	99
Rear	kPa	47	42
Loaded			
Front	kPa	142	124
Rear	kPa	174	151

SPEED

Forward		
1	km/h	5.8
2	km/h	8.5
3	km/h	10.4
4	km/h	15
5	km/h	21.6
6	km/h	27.3
7	km/h	36.1
8	km/h	47.8
9	km/h	57
Reverse		
1	km/h	6.5
2	km/h	9.4
3	km/h	18

Excavator PASS MATCHING

	EC480	EC750	EC950
A45G	Number of passes		
	8	5	4

Well matched, 4-6 buckets.

Excavator under capacity, 7 buckets or more.

Excavator undersized for optimum match.

Wheel loader PASS MATCHING

	L220	L250	L350
A45G	Number of passes		
	4	4	3

Well matched, 2-3 buckets.

Loader under capacity, 4 buckets or more.

Loader undersized for optimum match, reach might be an issue.

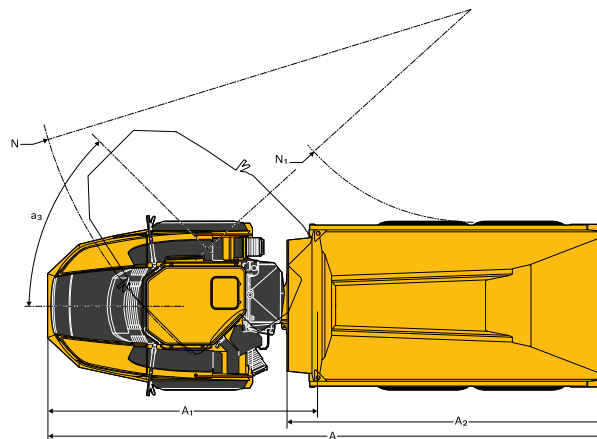
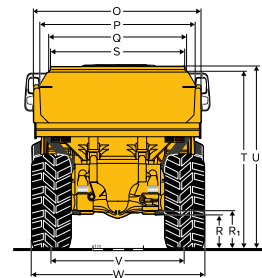
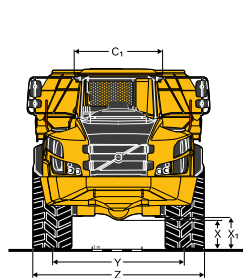
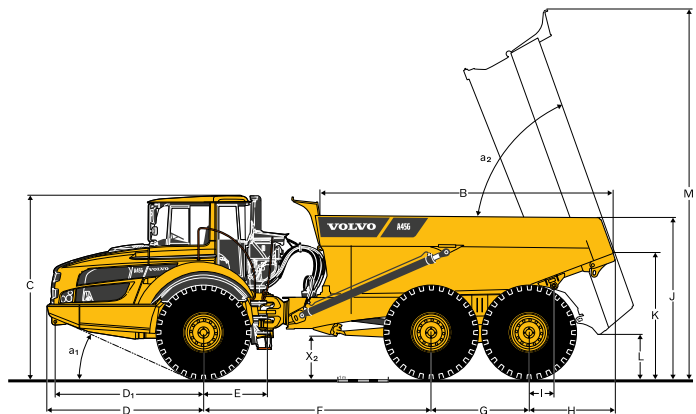

DIMENSIONS

Pos	Unit	A45G
A	mm	11 263
A ₁	mm	5 476
A ₂	mm	6 404
B	mm	5 844
C	mm	3 599
C ₁	mm	1 772
D	mm	3 100
D ₁	mm	2 942
E	mm	1 277
F	mm	4 518
G	mm	1 940
H	mm	1 706
I	mm	495
J	mm	3 200
K	mm	2 435
L	mm	822
M	mm	7 265
N	mm	8 957

DIMENSIONS

Pos	Unit	A45G
N ₁	mm	4 327
O	mm	3 430
P	mm	3 118
Q	mm	2 820
R	mm	613
R ₁	mm	701
S	mm	2 651
T	mm	3 427
U	mm	3 546
V	mm	2 636
W	mm	3 403
X	mm	553
X ₁	mm	645
X ₂	mm	788
Y	mm	2 636
Z	mm	3 403
a ₁	°	24
a ₂	°	70
a ₃	°	45

A45G: Unloaded machine with 29.5R25 tires.

Equipment

STANDARD EQUIPMENT

Engine

Direct injected, electronically controlled, turbocharged, intercooled
 Grouped oil filters, for ease of change
 Preheater for easier cold starts
 VEB (exhaust retarder EPG + compression brake)

Tires

29.5R25

Drivetrain

6x4 and 6x6 automatically engaged drive modes
 Dog clutch type 100% diff-locks in all axles
 Full automatic transmission
 Dropbox with longitudinal diff-lock
 Torque converter with automatic lock-up

Electrical system

120 A alternator
 Battery disconnect switch
 Extra 24 V socket for lunch cooler

Lights:

Back-up light
 Brake lights
 Cab lighting
 Direction indicators
 Headlights
 Instrument lighting
 Parking lights
 Rear lights

Brake System

Hill assist
 Load & Dump Brake
 Retarder pedal
 Parking brake on propeller shaft
 Two circuit, fully hydraulic, wet discs on all axles

Body

Body prepared for exhaust heating and optional equipment

Safety

Anti-slip steps and platforms
 Dump body lock
 Handrails on steps and platforms
 Hazard lights
 Horn
 Protective grill for cab rear window
 Rear-view mirrors
 Retractable 3-inch safety belt
 ROPS/ FOPS protected Care Cab
 Secondary steering
 Steering joint lock
 Windshield washers
 Windshield wipers with interval function
 Dump support system

STANDARD EQUIPMENT

Comfort

ACC control panel
 Ashtray
 Cab heater with filtered fresh air and defroster
 Can holder /storage tray
 Cigarette lighter
 Instructor seat with seat belt
 Overhead console for radio
 Sliding window
 Space for lunch cooler
 Storage box
 Sun visor
 Tilt/telescopic steering wheel
 Tinted glass

Operator information interface

Gauges:

Brake pressure
 Fuel
 Speedometer
 Tachometer
 Wet disc brakes cooling oil temperature

Warning lights grouped and easy to read

Central warning (3 levels) for all vital functions

Central positioned information display

Automatic pre-start checks
 Clock
 Hour meter
 Operational information, easy-to-navigate menu
 Troubleshooting diagnostics

Exterior

Front mudguard wideners and rear mudflaps

Service and Maintenance

Electrical engine hood and belly plate
 Drainage hose
 Machine Tracking Information System MATRIS
 Service platform integrated in the front grill
 Tool box

OPTIONAL EQUIPMENT

Engine

Air pre-cleaner, cyclone type
 Air pre-cleaner, oil-bath type
 Air filter, heavy duty, EON
 Engine heater, 240 V
 Engine heater, diesel (Eberspächer)
 Engine auto shutdown
 Engine shutdown timer
 External emergency engine stop
 Fuel filter, extra
 High engine idle speed

Tires

875/65R25

OPTIONAL EQUIPMENT

Electrical system

Headlights, LED
Warning beacon, LED
Working lights, halogen
Working lights, LED
Entrance light
Anti-theft system (pin code)
Rear view camera
Reverse alarm
CAN-BUS interface, extra

Cab

Noise reduction kit (fulfils 2000/14/EC)
Anchorage, operator's manual
Cab heating/ventilation timer
Cable kit, for cab heater 240 V
HEPA cab air filter
Bluetooth radio kit
Rear view mirrors, adjustable, el.heated
Seat belt XXL, non-retractable
Sun blinds, side windows
Universal key
Air suspended, heated, fully adjustable seat
Armrest for operator seat
Headrest for operator seat
Low profile cab

OPTIONAL EQUIPMENT

Body

Body exhaust heating
Front spillguard, extra
Side extension, 200 mm
Side extension, light material
Tailgate, overhung, linkage-operated
Tailgate, overhung, wire-operated
Tailgate, underhung
Wear plates, 450 HB
Underground body

Safety

Fire suppression system
Warning triangle
First aid kit and fire extinguisher
Fire extinguisher
Wheel chocks

Service and Maintenance

Lube system, standard machine
Lube system, tailgate
Lubrication hose, ground level greasing
Tool kit

Other

Siberian kit -40°C
On board weighing (OBW)
Arctic oil kit
CareTrack
Fast fuelling system
Jump start connector, NATO -type
Frame extension

SELECTION OF VOLVO OPTIONAL EQUIPMENT

Entrance light**On board weighing****Heavy duty air filter****Fast fuelling****Volvo fire suppression system****Rear view camera**

Not all products are available in all markets. Under our policy of continuous improvement, we reserve the right to change specifications and design without prior notice. The illustrations do not necessarily show the standard version of the machine.

VOLVO

Volvo Construction Equipment

volvoce.com