



Volvo Construction Equipment

A35G_{FS}, A40G_{FS}

VOLVO ARTICULATED HAULERS 33.5-39t 447-476hp



A passion for performance.

At Volvo Construction Equipment, we're not just coming along for the ride. Developing products and services that raise productivity – we are confident we can lower costs and increase profits for industry experts. Part of the Volvo Group, we are passionate about innovative solutions to help you work smarter – not harder.

Helping you to do more.

Doing more with less is a trademark of Volvo Construction Equipment. High productivity has long been married to low energy consumption, ease of use and durability. When it comes to lowering life-cycle costs, Volvo is in a class of its own.

Designed to fit your needs.

There is a lot riding on creating solutions that are suited to the particular needs of different industry applications. Innovation often involves high technology – but it doesn't always have to. Some of our best ideas have been simple, based on a clear and deep understanding of our customers' working lives.



You learn a lot in 180 years.

Over the years, Volvo has advanced solutions that have revolutionized the use of construction equipment. No other name speaks Safety louder than Volvo. Protecting operators, those around them and minimizing our environmental impact are traditional values that continue to shape our product design philosophy.

We're on your side.

We back the Volvo brand with the best people. Volvo is truly a global enterprise, one that is on standby to support customers quickly and efficiently – wherever they are.

We have a passion for performance.



Volvo Trucks



Renault Trucks



Mack Trucks



UD Trucks



Volvo Buses



Volvo Construction Equipment



Volvo Penta



Volvo Financial Services

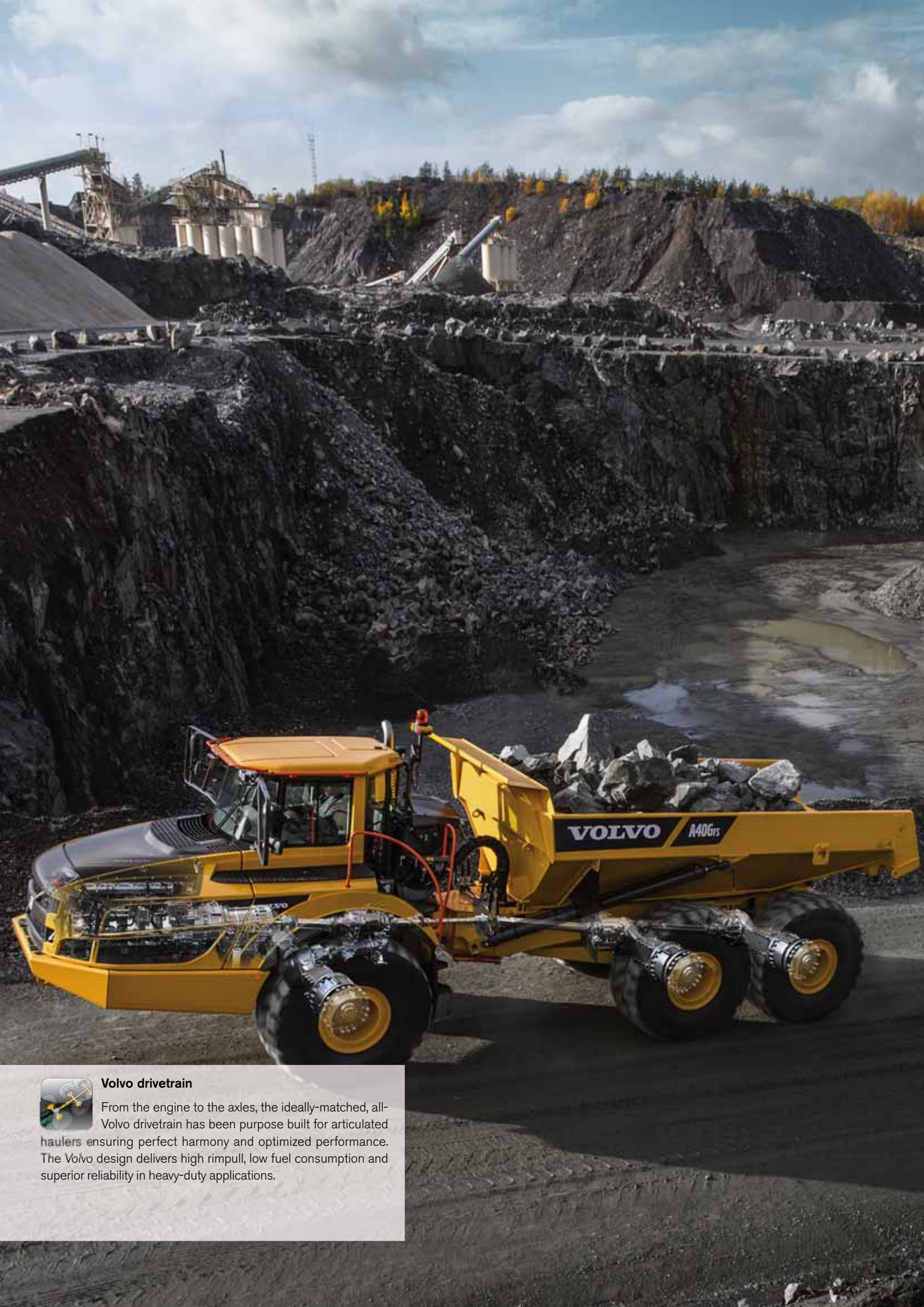

Volvo drivetrain

From the engine to the axles, the ideally-matched, all-Volvo drivetrain has been purpose built for articulated haulers ensuring perfect harmony and optimized performance. The Volvo design delivers high rimpull, low fuel consumption and superior reliability in heavy-duty applications.

The king of productivity.

The new G-Series Full Suspension haulers have been designed to set new standards in the market that Volvo created in 1966 when it invented the world's first articulated hauler. Whether you're working in the quarrying, mining, material handling, heavy earthmoving or any other application, these machines deliver the power, speed and productivity you expect from Volvo.

Volvo engine

Featuring advanced technology and built on decades of experience, the powerful, new Volvo engine meets the Stage IV/Tier 4f emission regulations and delivers the ultimate combination of high performance and low fuel consumption.

Wet brakes on all axles

Oil-cooled, wet, multiple disc brakes on all three axles deliver industry-leading braking performance, low operating costs and ultimate durability – even on the muddiest and dustiest sites. The powerful and easy-to-operate retardation system controls downhill hauling speed using the wheel brakes and the Volvo Engine Brake (VEB).



Automatic Traction Control (ATC) and differential locks

Volvo's unique design boasts 100% lockable, no-slip, no-wear differential locks in 6x4 and 6x6 drive combinations. ATC automatically activates the correct combination based on the ground conditions – ensuring optimal traction and mobility with reduced fuel consumption and tire wear. By locking all differentials, all wheels rotate at the same speed for maximum traction in tough terrain.

Superior off-road performance.

If you're looking for an articulated hauler that can perform in the toughest terrain and at high hauling speeds, then look no further than the full suspension range of haulers from Volvo Construction Equipment. These machines deliver a smooth and stable performance in the most demanding conditions.

Full Suspension System

Volvo's Full Suspension articulated haulers are fitted with fully hydraulic front and rear suspension – permitting high hauling speeds in tough conditions. Level sensors electronically monitor the frame movement

in relation to the axles and signal the hydraulic system to adjust the suspension. This optimizes stability during travel, loading and dumping. The cross flow between the hydraulic cylinders stabilize both the bogie and the tractor.



More comfort

The full suspension system monitors the hauler's wheel movements and stabilizes the machine based on the ground conditions – this delivers superior operator comfort. Enhanced machine stability allows for higher average speeds on rough haul roads, leading to increased productivity both when the machine is loaded and empty.

On Board Weighing (OBW) system

Volvo's award-winning OBW technology provides unprecedented insight into machine productivity. The system monitors the input of weight on the machine from full suspension pressure sensors and relays this information to load software integrated into the machine's electronics. This helps optimizing payload and the machine wear, tire damage and excess fuel efficiency that go with it.

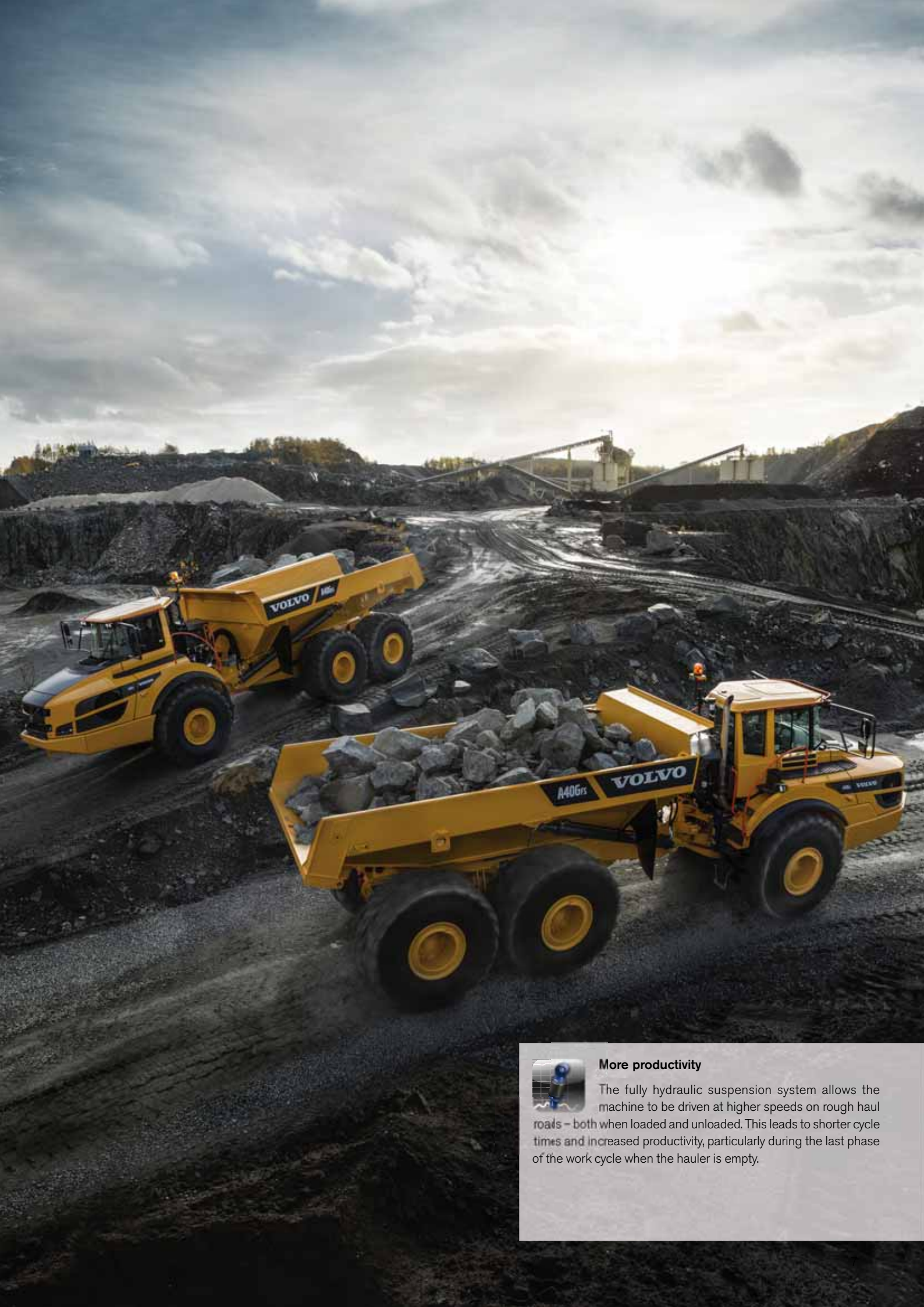

More productivity

The fully hydraulic suspension system allows the machine to be driven at higher speeds on rough haul roads – both when loaded and unloaded. This leads to shorter cycle times and increased productivity, particularly during the last phase of the work cycle when the hauler is empty.



Articulation and oscillation joint

The connection between the tractor and the trailer unit has high ground clearance, industry-leading hydro-mechanical steering and a maintenance free rotating hitch design. This combination boosts accessibility and drivability in severe conditions and maximizes uptime.

Superior in every way.

If you're looking for a strong and durable hauler to handle the most severe, heavy-duty applications then look no further than the new F-Series Full Suspension haulers. These machines deliver superior off-road hauling performance, at high speeds, in the toughest conditions.

Hydro-mechanical steering

Unique, self-compensating, hydro-mechanical system provides precise steering, excellent maneuverability and a short turning radius. Volvo's superior system delivers powerful and accurate steering, ensuring outstanding machine control and highly productive, safe operation.



Maintenance free rotating hitch

For high uptime and low operating costs, the 100% maintenance free, sealed hitch, features permanently greased tapered roller bearings. It allows independent movement of the tractor and trailer without frame twist, while providing oscillation for good ground contact in rough conditions.

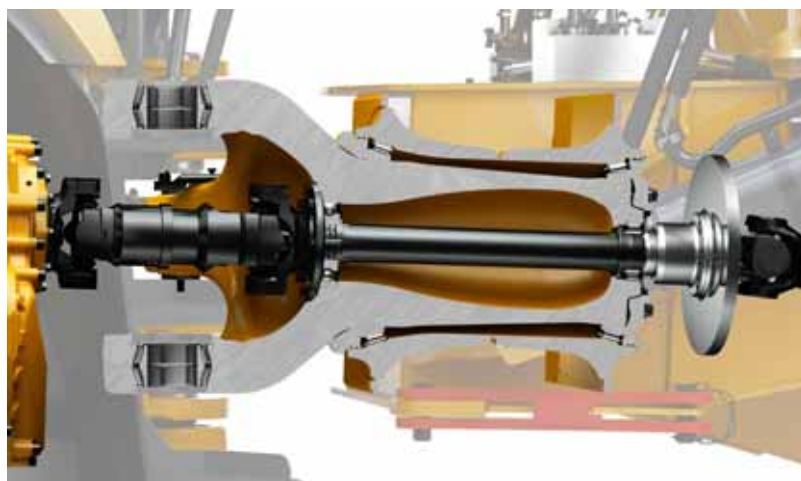

Durable frames

Heavy-duty, rigid front and rear frames have been designed for severe off-road operations and long life-span. The robust Volvo design is utilizing robotic welding for ultimate quality and durability.

Adding value to your business.

Being a Volvo customer means having a complete set of services at your fingertips. Volvo can offer you a long-term partnership, protect your revenue and provide a full range of customer solutions using high quality parts, delivered by passionate people. Volvo is committed to increasing the positive return on your investment and maximising uptime.



Complete Solutions

Volvo has the right solution for you. So why not let us provide all your needs throughout the whole life cycle of your

machine? By listening to your requirements, we can reduce your total cost of ownership and increase your revenue.



Genuine Volvo Parts

Our attention to detail is what makes us stand out. This proven concept acts as a solid investment in your machine's future. Parts are extensively tested and approved because every part is vital for uptime and performance. Only by using Genuine Volvo Parts, can you be sure that your machine retains the renowned Volvo quality.



Service Network

In order to respond to your needs faster, a Volvo expert is on the way to your job site from one of our Volvo facilities. With our extensive infrastructure of technicians, workshops and dealers, Volvo has a comprehensive network to fully support you using local knowledge and global experience.



SERVICE PLAN

	DAY01	DAY02	DAY03	DAY04	DAY05	DAY06	DAY07
Task 1						✓	
Task 2				✓	✓		
Task 3	✓						
Task 4			✓			✓	✓
Task 5							
Task 6	✓						
Task 7			✓				
Task 8							



Customer Support Agreements

The range of Customer Support Agreements offer preventive maintenance, total repairs and a number of uptime services. Volvo uses the latest technology to monitor machine operation and status, giving you advice to increase your profitability. By having a Customer Support Agreement you are in control of your service costs.

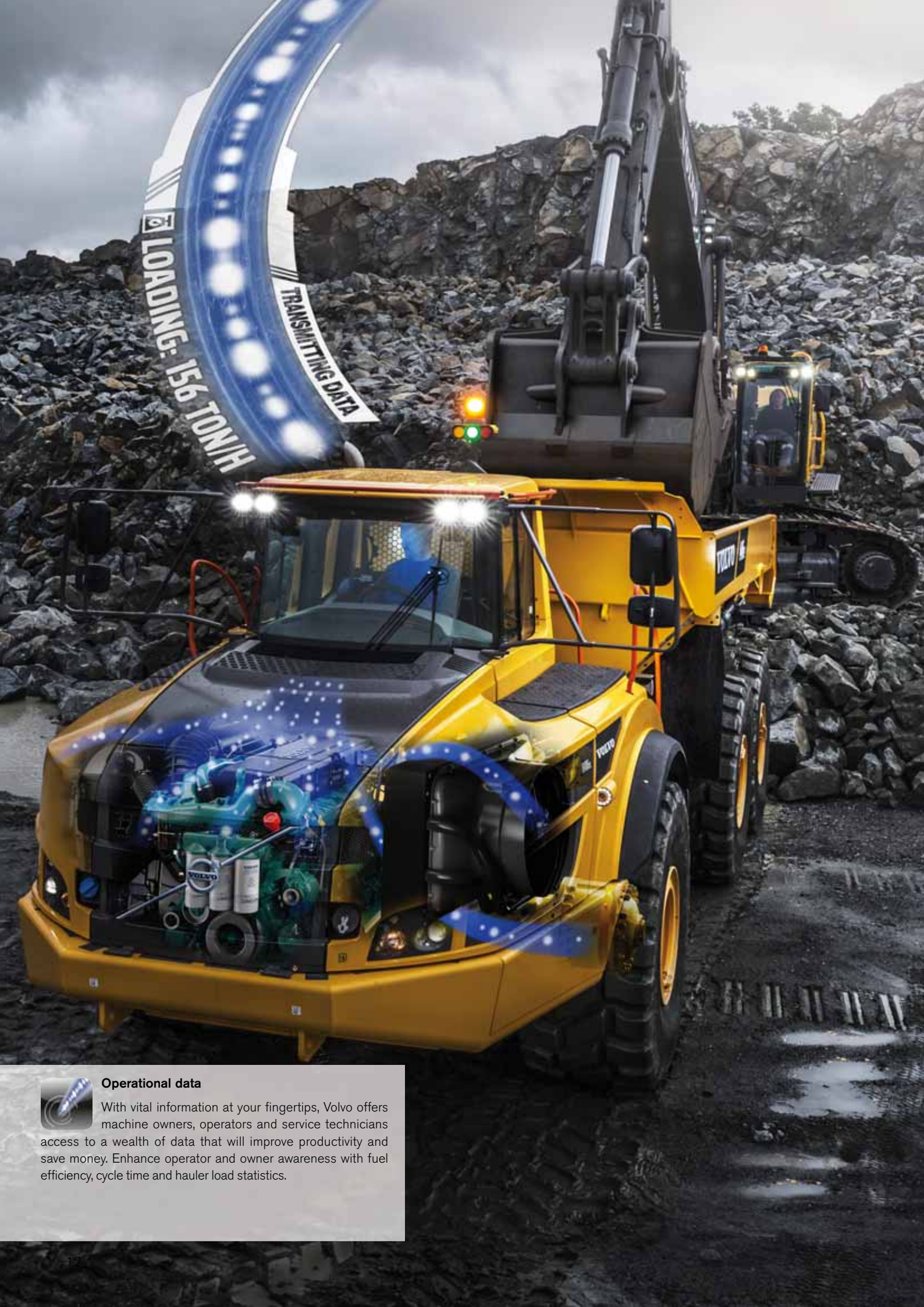

Operational data

With vital information at your fingertips, Volvo offers machine owners, operators and service technicians access to a wealth of data that will improve productivity and save money. Enhance operator and owner awareness with fuel efficiency, cycle time and hauler load statistics.

The key to profitability.

Unlock the secret to hauler productivity with innovations including Volvo's telematics system, revolutionary On Board Weighing technology and diagnostic tools. Volvo gives you access to important information – including fuel consumption and productivity data – to improve performance and increase machine availability. It all adds up to more with Volvo.

CareTrack

Volvo articulated haulers are equipped with CareTrack¹, the company's telematics system. CareTrack provides information to improve productivity and efficiency – including fuel consumption data, location reports and service reminders.

¹In markets where CareTrack is available.

On Board Weighing (OBW)

Exterior load indicator lights are visible to the operator loading the hauler – illuminating yellow at part load, green at nominal load and red when overloaded. OBW logs all transported loads for complete payload management and presents this data on the operator display. The information can be accessed remotely via CareTrack, the Volvo telematics system.



Contronics

Contronics continuously provides valuable information on the hauler's systems and operation. Diagnostics and data needed for optimum operation, such as malfunction indicators, are communicated to the operator via a color monitor, which together with a keypad, provide easy navigation between different screens and functions.

MATRIS

This tool uses information from the machine to analyze and monitor operation. MATRIS analysis supports optimized performance by tracking activity characteristics and identifying opportunities for improvement – resulting in better fuel economy, efficient operation and longer machine life.

The ultimate hauling experience.



Articulation and oscillation joint

The connection between the tractor and the trailer unit has high ground clearance and a maintenance free rotating hitch design.

Dumping functionality

Volvo's patented, user-friendly load and dump brake technology and tipping lever deliver precise dumping control and faster cycle times.



Operational data

Volvo offers machine owners, operators and service technicians access to a wealth of vital data that will control productivity and save money.

CareTrack

Volvo's telematics system guides machine owners towards optimized productivity and their next service – remotely.

Automatic Traction Control (ATC) and differential locks

Volvo's unique design boasts 100% lockable, no-wear differential locks in 6x4 and 6x6 drive combinations, ensuring excellent rimpull at all times.

Wet brakes

Oil-cooled, wet, multiple disc brakes on all three axles deliver industry-leading braking performance and low operating costs – even on the muddiest and dustiest sites.



On Board Weighing (OBW)

OBW logs all transported loads for complete payload management. The data is presented on the operator display as well as remotely via CareTrack, the Volvo telematics system.



Volvo Care Cab

The centrally positioned operator station features ergonomically positioned controls, all-around visibility and low internal noise levels for high productivity throughout the shift.



Full Hydraulic Suspension

Unique full hydraulic suspension on all wheels, for increased productivity combined with maximum operator comfort and excellent off-road performance.

Hydro-mechanical steering

Unique, self-compensating, hydro-mechanical system provides precise steering, excellent maneuverability and directional stability at high speeds.



Service access

The front grill swings down, acting as a service platform with anti-slip steps. There is full, safe access to the engine compartment via the 90 degree tilting hood.



Volvo drivetrain

The ideally-matched, all-Volvo drivetrain with unique high-ground clearance inline dropbox, has been purpose built for articulated haulers ensuring perfect harmony and optimized performance.

Volvo engine

The new, powerful Stage IV/ Tier 4f Volvo engine delivers the ultimate combination of high performance and high fuel efficiency.



Volvo Care Cab

The centrally positioned operator station features ideally placed pedals, controls and switches and all-around visibility from a wide front windshield, full-glass door, sloping hood and large rear-view mirrors. With effective sound insulation, the spacious ROPS/FOPS cab has low internal noise levels for high productivity throughout the shift.

Comfort matters – especially in the cab. That's why Volvo has designed the best workplace in the industry. With ample space and all-around visibility, the Volvo Care Cab successfully delivers comfort both in demanding terrain and at high hauling speeds – ensuring reduced fatigue and high productivity.

Comfort in tough terrain.

Dumping functionality

Precise dumping control and faster cycle times are delivered through Volvo's patented, user-friendly load and dump brake technology. Together with the tipping lever – which provides automatic float and body lowering– this facilitates ease of operation and reduced fatigue.

Safe access

With no threshold to cross, the operator can easily enter and exit the cab through the wide opening door. Anti-slip steps and conveniently placed handrails provide safe entry and exit.

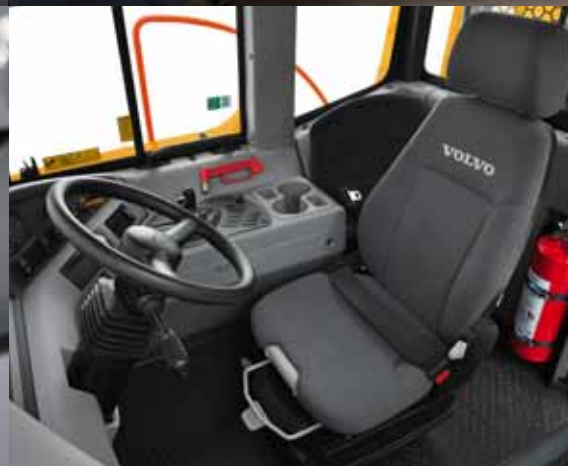

Climate control system

With more than 98% efficiency, Volvo's air filtration system provides the cleanest operator environment in the industry – even in dusty conditions. The high-capacity heating and ventilation system improves comfort, enhancing productivity. Separate defroster vents keep the windows clear.

Seat offering

A variety of air-suspended seat combinations offer improved operator comfort. Choose from a two, three-point seatbelt. For maximum comfort, select the optional armrest and head restraint.

Increase your uptime with Volvo.

On site, time means money. That's why Volvo's articulated haulers boast safe and easy access to grouped service points for fast and effortless maintenance and service checks. Maximize your uptime and get the most out of each working day with Volvo.

Swing-down grill

Grouped engine oil filters are easily accessed via the swing-down front grill. The special valve in the belly plate and a dedicated drainage hose, stored in the front grill, ensure fast oil change without spillage.

Retardation system

Fully enclosed, wet disc brakes feature an external cooling system that absorbs heat and filters the oil from the brakes even when the machine is at a standstill. This prevents contamination while ensuring low operating costs and long service life.



Automatic monitoring

For maximum uptime and machine availability, the Contronics system electronically monitors fluid levels, providing deviation warnings and scheduled service reminders. This can also be accessed remotely via CareTrack, Volvo's telematics system.



Service access

The front grill swings down, acting as a service platform with anti-slip steps. The hood tilts up to 90 degrees for full and safe access to the engine compartment. This makes reaching service points, changing filters and cleaning the cooling package quicker and easier.

Volvo A35GFs, A40GFs in detail.

Engine

V-ACT, 6-cylinder straight VGT (Variable Geometry Turbocharged) diesel engine with 4 valves per cylinder, overhead camshaft and electronically controlled unit injectors. It has wet replaceable cylinder liners and replaceable valve guides and valve seats. The engine has cooled EGR (Exhaust Gas Recirculation) and exhaust after treatment with EAT-Muffler (Exhaust After treatment) including DOC (Diesel Oxidation Catalyst), DPF (Diesel Particulate Filter) and SCR (Selective Catalytic Reduction) with an electronically controlled UDS (Urea Dosing System). The after treatment system features passive DPF regeneration, keeping active regeneration to a minimum. Cooling system: High capacity cooling system with power and fuel saving, variable speed hydraulic driven fans.

A35GFs		Volvo D13J (Tier 4f / Stage IV)
Max power at	r/s	31.7
SAE J1995 Gross	kW	329
Flywheel power at	r/s	31.7
ISO 9249, SAE J1349 Net	kW	327
Max torque at	r/s	20
SAE J1995 Gross	Nm	2 360
ISO 9249, SAE J1349 Net	Nm	2 345
Displacement	l	12.8
A40GFs		Volvo D16J (Tier 4f / Stage IV)
Max power at	r/s	30
SAE J1995 Gross	kW	350
Flywheel power at	r/s	30
ISO 9249, SAE J1349 Net	kW	347
Max torque at	r/s	17.5
SAE J1995 Gross	Nm	2 525
ISO 9249, SAE J1349 Net	Nm	2 500
Displacement	l	16.1

Drivetrain

Torque converter with built-in lock-up function.
Transmission: Fully automatic Volvo PowerTronic planetary transmission with nine forward gears and three reverse gears. The transmission has the ability to skip gears for fast and accurate gear selection
Dropbox: Volvo-developed, in-line design with high ground clearance and 100% longitudinal "dog clutch" type differential lock.
Axles: Heavy duty, purpose built Volvo design with fully floating axle shafts, planetary type hub reductions and 100% dog clutch type diff-lock.
Automatic traction control system (ATC).

A35GFs/A40GFs

Torque converter	2.1:1
Transmission, Volvo	PT 2519
Dropbox, Volvo	IL2 ATC
Axles, Volvo	ARB H35/H40

Electrical System

Cables are enclosed in plastic conduits, secured to the main frame. All cables, sockets and pins are identified. Prewired for options. Connectors meet IP67 standard for water-proofing. Easy accessed battery disconnect switch. Halogen lights. Powerful LED lights is optional.

A35GFs/A40GFs

Voltage	24
Battery capacity	2x170/2x225 Ah
Alternator	2.26 kW (80 A)
Starter motor	9.0 kW





Volvo A35GFs, A40GFs in detail.

Brake System

Complies with ISO 3450.
Fully hydraulic, wet multiple disc brakes with enclosed, forced oil-cooled multiple discs on all wheels.
Two independent circuits: one for front axle and one for bogie axles.
Secondary brake: Dual brake circuits with rechargeable accumulators.
Parking brake: spring-applied disc brake on the propeller shaft.
Retarder: Service brake retarder function and Volvo Engine Brake (VEB).

Steering System

Hydro-mechanical articulated steering, self compensating design.
Two double-acting steering cylinders.
Steering angle: 3.4 steering wheel turns lock-to-lock, $\pm 45^\circ$.
Steering system, including secondary steering fulfills ISO 5010.

Chassis

Frames: box type, heavy duty. High strength steel, robot welded.
Rotating hitch: 100% maintenance free, fully sealed, with permanently greased tapered roller bearings.

Suspension

Unique, full hydraulic, on all wheels with automatic leveling and stabilizer. Part of the machine's hydraulic system, uses the same hydraulic oil.

A35GFs/A40GFs

Hydraulic cylinders (struts), front/rear	2/4
Accumulators, oil-nitrogen, high pressure, front	2
Accumulators, oil-nitrogen, high/low pressure, rear	2/2
Levelling sensors	2+2+2

Cab

Mounted on rubber pads. Ergonomically designed. Easy entry and exit. Wide angle forward view.
Operator centrally positioned above the front axle. Adjustable operators seat with retractable seat belt.
Tilt/telescopic steering wheel. Ergonomically positioned controls.
Filtered air. Optional climate control system.
Operator communication system: Contronics.
Large color display, user-friendly and easy-to-understand information, all vital machine functions are constantly monitored.
Instructor seat with seat belt.
Safety: ROPS/FOPS standards approved according to ISO3471, SAE J1040 / ISO3449, SAE J231.
Sound level in cab according to ISO 6396: 74 dB(A).
External sound level* according to ISO 6395: 110 dB(A).

* with Noise Reduction Kit

Hydraulic System

Pumps: Five variable displacement piston pumps driven by the flywheel PTO. One ground-dependent piston pump for secondary steering mounted on the dropbox.
Two return oil filters with magnetic cores provide effective oil filtration.
System max working pressure is 25 MPa.
Full suspension system max pressure is 23.5 MPa.

Dumping System

Patented Load and Dump Brake.
Dumping Cylinders: two single stage double acting cylinders.

A35GFs/A40GFs

Tipping angle	°	72/70
Tipping time with load	sec	12
Lowering time	sec	10

Body

Plate thickness:

Front	mm	8
Sides	mm	12
Bottom	mm	16
Chute	mm	16

Material: HB400 steel

Yield strength	N/mm ²	1 000
Tensile strength	N/mm ²	1 250

Load Capacity

	A35GFs	A40GFs
--	--------	--------

Standard Body

Load capacity	kg	33 500	39 000
Body, struck	m ³	16.0	18.4
Body, heaped 2:1	m ³	20.5	24.0

With overhung tailgate

Body, struck	m ³	16.4	18.8
Body, heaped 2:1	m ³	21.4	24.7

Specifications.

Fill capacities	A35Gfs	A40Gfs
	litre	
Crankcase	50	54
Fuel tank	480	480
Cooling system	75	75
Transmission	40	40
Dropbox	9	9
Axles, front/bogie	26/56	26/56
Brake cooling system	226	226
Hydraulic tank	175	175
DEF/AdBlue	39	39

Speed	A35Gfs	A40Gfs
	km/h	
Forward		
1	6	6
2	8	9
3	11	10
4	15	15
5	22	22
6	28	27
7	37	36
8	49	48
9	57	57
Reverse		
1	7	7
2	10	9
3	18	18

Operating weight unloaded	A35Gfs	A40Gfs
	26.5R25*	29.5R25**
Tires	kg	
Front	16 100	16 700
Rear	13 500	14 500
Total	29 600	31 200
Payload	33 500	39 000

Total weight	A35Gfs	A40Gfs
	26.5R25*	29.5R25**
Tires	kg	
Front	19 100	20 700
Rear	44 000	49 600
Total	63 100	70 200

Operating weight includes all fluids and operator

*) A35Gfs with tires 775/65R29, add 200 kg/axle ***) A40Gfs with tires 875/65R29, add 300 kg/axle

Ground Pressure	A35Gfs		A40Gfs	
	26.5R25	775/65R29	29.5R25	875/65R29
Tires	kPa			
Unloaded				
Front	135	114	119	99
Rear	57	48	52	43
Loaded				
Front	161	136	147	122
Rear	185	156	177	146

Pos	A35Gfs	A40Gfs
	mm	
A	11 180	11 263
A ₁	5 476	5 475
A ₂	6 241	6 404
B	5 540	5 821
C	3 716	3 768
C ₁	3 546	3 597
C ₂	1 772	1 772
D	3 101	3 101
D ₁	2 941	2 942
E	1 277	1 277
F	4 578	4 518
G	1 820	1 940
H	1 683	1 706
I	650	495
J	2 995	3 154
K	2 314	2 457
L	900	844
M	7 248	7 287
N	8 853	8 967
N ₁	4 395	4 307
O	3 106	3 374
P	2 870	3 074
Q	2 553	2 730
R	579	635
R ₁	604	644
S	2 422	2 653
T	3 401	3 462
U	3 516	3 565
V	2 534	2 636
V*	2 625	2 709
W	3 258	3 433
W*	3 410	3 570
X	521	571
X ₁	617	671
X ₂	754	807
Y	2 534	2 636
Y*	2 625	2 709
Z	3 258	3 433
Z*	3 410	3 570
a ₁	23,6°	25°
a ₂	72°	70°
a ₃	45°	45°

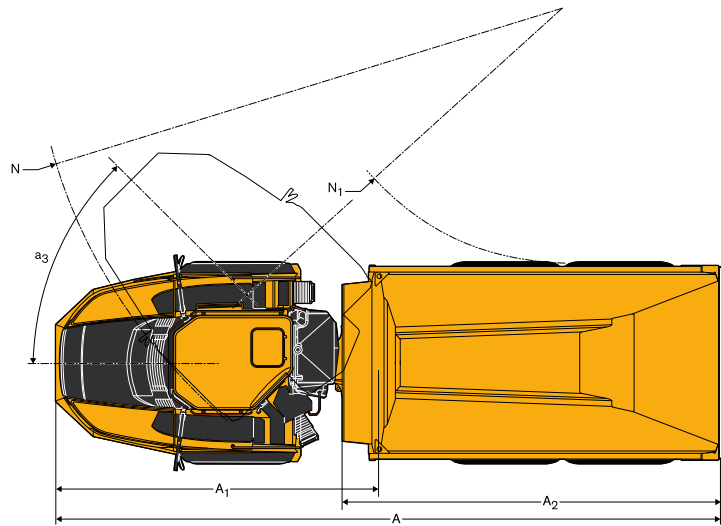
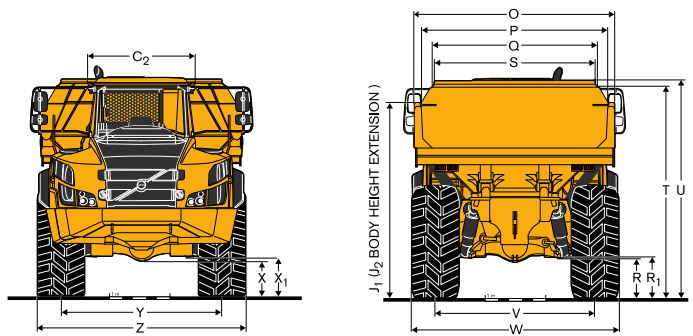
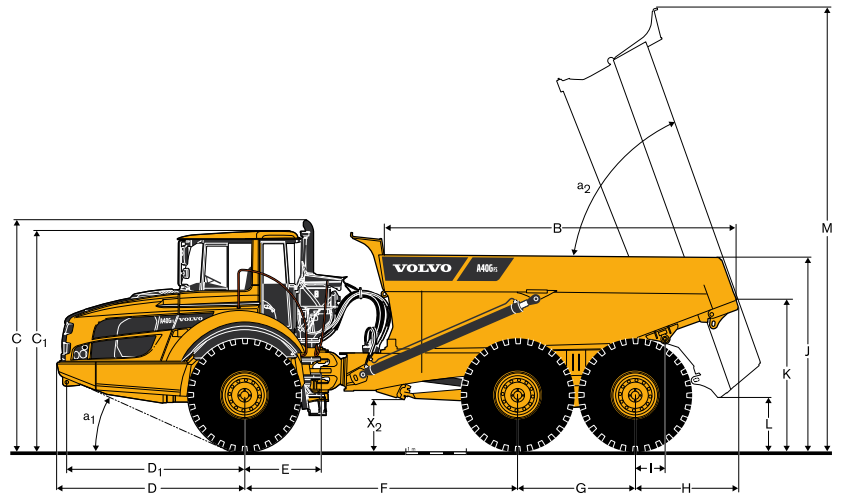

A35G FS: Unloaded machine with 26.5R25
A40G FS: Unloaded machine with 29.5R25
*) A35G FS with optional 775/65R29 tires;
A40G FS with optional 875/65R29 tires.

Equipment.

STANDARD EQUIPMENT

	A35Gfs	A40Gfs
Safety		
Anti-slip steps and platforms	•	•
Dump body lock	•	•
Handrails on steps and platforms	•	•
Hazard lights	•	•
Horn	•	•
Protective grill for cab rear window	•	•
Rear-view mirrors	•	•
Retractable 3-inch safety belt	•	•
ROPS/ FOPS protected Care Cab	•	•
Secondary steering	•	•
Steering joint lock	•	•
Windshield washers	•	•
Windshield wipers with interval function	•	•
Drivetrain		
6x4 and 6x6 automatically engaged drive modes	•	•
Dog clutch type 100% diff-locks in all axles	•	•
Full automatic transmission	•	•
Hydraulic variable retarder	•	•
Single stage dropbox with longitudinal diff-lock	•	•
Torque converter with automatic lock-up	•	•
Engine		
Direct injected, electronically controlled, turbocharged, intercooled	•	•
Grouped oil filters, for ease of change	•	•
Preheater for easier cold starts	•	•
Remote oil drain valve and hose for easy access	•	•
VEB (exhaust retarder EPG + compression brake)	•	•
Electrical system		
80 A alternator	•	•
Battery disconnect switch	•	•
Extra 24 V socket for lunch cooler	•	•
Lights:		
Back-up light	•	•
Brake lights	•	•
Cab lighting	•	•
Direction indicators	•	•
Headlights	•	•
Instrument lighting	•	•
Parking lights	•	•
Rear lights	•	•
Brake system		
Load & Dump Brake	•	•
Parking brake on propeller shaft	•	•
Two circuit, fully hydraulic, wet discs on all axles	•	•

	A35Gfs	A40Gfs
Comfort		
Ashtray	•	•
Cab heater with filtered fresh air and defroster	•	•
Can holder /storage tray	•	•
Cigarette lighter	•	•
Instructor seat with seat belt	•	•
Overhead console for radio	•	•
Sliding window	•	•
Space for lunch cooler	•	•
Storage box	•	•
Sun visor	•	•
Tilt/telescopic steering wheel	•	•
Tinted glass	•	•
Operator information interface		
Gauges:		
Brake pressure	•	•
Fuel	•	•
Speedometer	•	•
Tachometer	•	•
Warning lights grouped and easy to read		
Central warning (3 levels) for all vital functions	•	•
Central positioned information display:		
Automatic pre-start checks	•	•
Clock	•	•
Hour meter	•	•
Operational information, easy-to-navigate menu	•	•
Troubleshooting diagnostics	•	•
Body		
Body prepared for exhaust heating and optional equipment	•	•
Exterior		
Front mudguard wideners and rear mudflaps	•	•
Tires		
23.5R25	•	
750/65R25		•
Service and maintenance		
Drainage hose stored in the front grill	•	•
Machine Tracking Information System MATRIS	•	•
Service platform integrated in the front grill	•	•
Tool box	•	•

OPTIONAL EQUIPMENT

	A35Gfs	A40Gfs
Safety		
Fire-extinguisher and first aid kit	•	•
Warning triangle	•	•
Volvo Fire Suppression System	•	•
Engine		
Air pre-cleaner, cyclone type	•	•
Air pre-cleaner, heavy-duty, dry type EON	•	•
Electric engine heater (120V or 240V)	•	•
Engine automatic shutdown	•	•
External emergency engine stop	•	•
High engine idle speed	•	•
Electrical system		
Anti-theft system (prevents engine start)	•	•
Rear vision system, colour LCD monitor in the cab	•	•
Reverse alarm	•	•
Rotating/flashing warning beacon	•	•
Headlights, LED	•	•
Working lights, front and rear	•	•
Working lights LED, front and rear	•	•
Entrance light	•	•
Cab		
Air suspended, heated, fully adjustable seat	•	•
Armrest for operator seat	•	•
Cable kit for cab heater (120V or 240V)	•	•
Electrically heated and adjustable rear view mirrors	•	•
Electronic Climate Control (ECC)	•	•
Head restraint for operator seat	•	•
HEPA cab air filter	•	•
Radio installation kit, including loudspeakers	•	•
Radio with CD player	•	•
Sun blinds, side windows	•	•
Seat belt, XXL	•	•
Body		
Exhaust heating	•	•
Extra front spillguard, bolt-on	•	•
Light material extension, bolt-on kit	•	•
Overhung tailgate, wire or linkage operated	•	•
Side extensions 200 mm (8"), welded	•	•
Underhung tailgate, linkage operated	•	•
Wear plates for heavy duty applications	•	•
On Board Weighing (OBW)	•	•
Tires		
775/65R29	•	
875/65R29		•
Service and maintenance		
Automatic lubrication system	•	•
Electrical hood opening	•	•
Other		
Arctic oil kit	•	•
Lifting tools, wheel mounted	•	•
Synthetic hydraulic oil (biologically degradable)	•	•
CareTrack	•	•

Not all products are available in all markets. Under our policy of continuous improvement, we reserve the right to change specifications and design without prior notice. The illustrations do not necessarily show the standard version of the machine.

SELECTION OF VOLVO OPTIONAL EQUIPMENT

Tailgate, overhung, wire-operated



Entrance light



Grammer seat



On Board Weighing (OBW)



Work lights, LED



Headlights, LED



VOLVO

Volvo Construction Equipment

www.volvoce.com