

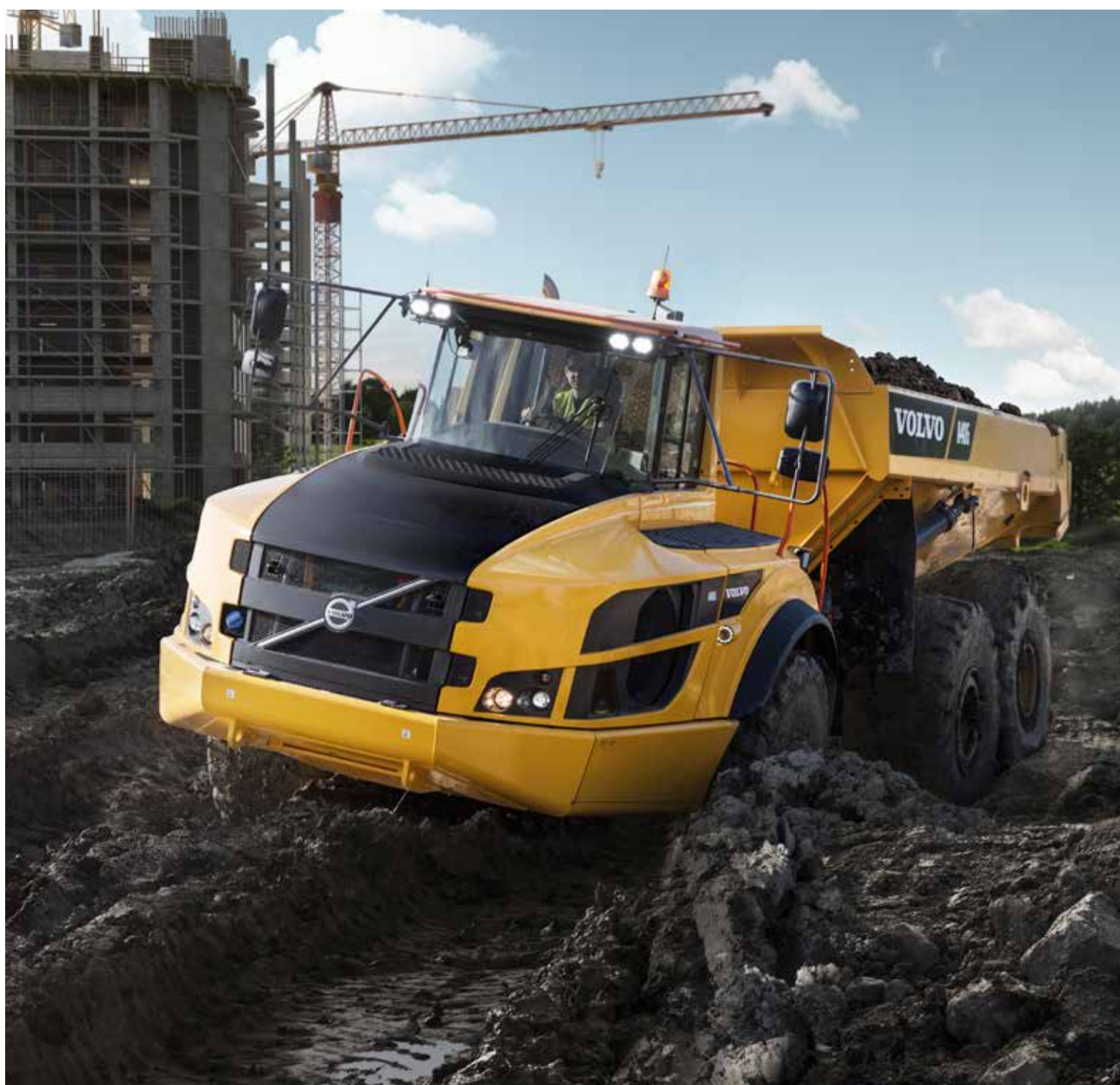

Volvo Construction Equipment

# A35G, A40G

Volvo Articulated Haulers 34.5-39 t 447-475 hp



# A passion for performance

At Volvo Construction Equipment, we're not just coming along for the ride. Developing products and services that raise productivity – we are confident we can lower costs and increase profits for industry experts. Part of the Volvo Group, we are passionate about innovative solutions to help you work smarter – not harder.

## Helping you to do more

Doing more with less is a trademark of Volvo Construction Equipment. High productivity has long been married to low energy consumption, ease of use and durability. When it comes to lowering life-cycle costs, Volvo is in a class of its own.

## Designed to fit your needs

There is a lot riding on creating solutions that are suited to the particular needs of different industry applications. Innovation often involves high technology – but it doesn't always have to. Some of our best ideas have been simple, based on a clear and deep understanding of our customers' working lives.



## You learn a lot in 180 years

Over the years, Volvo has advanced solutions that have revolutionized the use of construction equipment. No other name speaks Safety louder than Volvo. Protecting operators, those around them and minimizing our environmental impact are traditional values that continue to shape our product design philosophy.

## We're on your side

We back the Volvo brand with the best people. Volvo is truly a global enterprise, one that is on standby to support customers quickly and efficiently – wherever they are.

## We have a passion for performance.



Volvo Trucks



Renault Trucks





Mack Trucks



UD Trucks



Volvo Buses



Volvo Construction Equipment



Volvo Penta



Volvo Financial Services

# Pure uptime

Get ready to work with the new Volvo articulated hauler. Designed for heavy hauling in severe off-road operation, the machine's long service life, quality, reliability and durability is everything you expect from a Volvo. Hauling is easier and more efficient.

## Guaranteed durability

Increase your uptime using heavy-duty front and rear frames, hitch and wet disk brakes. Volvo proven durability and the support of extensive warranty options means you never need to worry about getting the job done. Strength and durability are hallmarks of the Volvo articulated hauler.



## Fifty years strong

Fifty years and fifty tonnes later, Volvo is the world's leading manufacturer of articulated haulers. We invented the concept and have been developing and building these machines for over 50 years – it has come a long way from its original 10 tonne articulated hauler. With proven success over the years, the machines include innovative technology and the renowned Volvo engine.



## Service access

With industry-leading access, servicing your machine is quick and easy. The front grill swings down, opening a service platform with anti-slip steps. The electric hood opens to 90 degrees, allowing full and safe access to the engine compartment.



## Volvo dealer network

The exclusive Volvo dealer network is there to support you whenever you need it. Volvo offers a number of services, local knowledge and global experience, including telematics machine monitoring – CareTrack™ and MATRIS™ – as well as superb parts availability.







# UPTIME

Get ready to work with the all new A35G/A40G. Designed for heavy hauling in severe off-road operation, the machine's long service life, quality, reliability and durability is everything you expect from a Volvo. Hauling is easier and more efficient.





# FUEL EFFICIENCY GUARANTEED

The new A35G, A40G has guaranteed fuel efficiency, providing up to 10% more efficiency. The Volvo engine's lower idle speed delivers an additional fuel saving for the most efficient machine.



# Incredible efficiency

Improve your efficiency and move more for less. Excellent fuel efficiency, innovative technology and useful operational data tools help to control your maintenance costs and maximize your investment.

## Move more for less

The machine is optimized for efficiency featuring higher payload capabilities. Its smart design allows for more capacity while reducing fuel consumption so you can move more for less.



## Operational data

Receive valuable data to improve onsite efficiency and save costs. With intelligent systems from Volvo such as MATRIS™, CareTrack™ and the On Board Weighing system, you will optimize your production and minimise your operational costs.



## Control your maintenance costs

The range of Customer Support Agreements offer preventive maintenance, total repairs and a number of uptime services. Volvo uses the latest technology to monitor machine operation and status, giving you advice to increase your profitability. By having a Customer Support Agreement you are in control of your service costs.



## Volvo dynamic drive

Dynamic and predictive gear selection adapts to operating conditions, for improved comfort and fuel efficiency.



# Hit the targets

Hit your targets with the A35G, A40G. This machine features 100% off-road performance, proven Volvo technology and increased payload – contributing to sustainable operations, year after year.

## Articulated hauler concept

Go where others can't. The articulated hauler concept provides total versatility so you can access the entire jobsite and climb steeper gradients. Work in all seasons, terrains and applications. With body building solutions and different chassis options you can tailor the machine to your jobsite.



## The best articulated hauler

The A35G/A40G machine delivers unbeatable off-road performance in its class with features including matched Volvo drivetrain, Automatic Traction Control including 100% differential locks, all-terrain bogie, hydro-mechanical steering.



## The right speed for the job

Ensure the right speed for your job using the retarders and dynamic Volvo Engine Brake to adapt your speed for maximum productivity and safety.



## Load optimization

The optional On Board Weighing System guarantees the optimal load every cycle. This maximizes production, boosts fuel efficiency and reduces machine wear in all site conditions and operations.







# PRODUCTIVITY

With superior productivity you can carry more in one go. The A35G, A40G articulated hauler is built to improve your cycle times and productivity.

# Get ready for heavy hauling

## OPERATOR'S CHOICE

Its comfortable cab and ease of operation, even in adverse conditions, makes operators choose this machine.

### New dump support system

The new dump support system increases stability and control in tough environments.

### Guaranteed durability

With body building solutions and different chassis options you can tailor the machine to your jobsite.

### Fifty years strong

Fifty years and fifty tonnes later, Volvo is the world's leading manufacturer of articulated haulers.

### New econometer

The new econometer help the operator to control the machine for extra productivity.

## UPTIME

Designed for heavy hauling in severe off-road operation, its long service life, quality, reliability and durability is everything you expect from a Volvo.

### New gradient controls

New hill assist and dynamic Volvo Engine Brake features give you more control over your machine, whether travelling up or down steep gradients.





## FUEL EFFICIENCY GUARANTEED

Powered by the world-renowned Volvo engine delivers excellent fuel efficiency without compromising on power or performance.

### The best articulated hauler

Unbeatable off-road performance and the best articulated hauler in its class.

## PRODUCTIVITY

Move more tonnes per hour and give a 100% in all conditions.



### Volvo dynamic drive

Gear shifting adapts dynamically to operating conditions, for improved comfort and fuel efficiency.

### Service access

With industry-leading access, servicing your machine is quick and easy.



# OPERATOR'S CHOICE

When many other machines are onsite, most operators prefer the Volvo. Its comfortable cab and ease of operation, even in adverse conditions, makes operators choose this machine.



# Control in comfort

The A35G, A40G is the number one operator's choice because of its industry-leading spacious cab and comfortable work environment. Its superior comfort, control, ease of operation and safety appeals to operators, maintaining productivity all day, every day.

## Total operator control

The new dump support system, hill assist, dynamic Volvo Engine Brake control and econometer as well as load and dump brake, help the operator control the machine for extra productivity and safety in all conditions.



## Ease of operation

The ergonomic, comfortable controls are easy to understand and suit all operators, combined with automatic functions for increased ease of operation.



## Operator comfort

Feel comfortable and spend more time in the A35G/A40G. The centrally positioned operator, superior steering, excellent suspension, low noise levels, climate control, space and visibility, reduce operator fatigue for more effective operations.

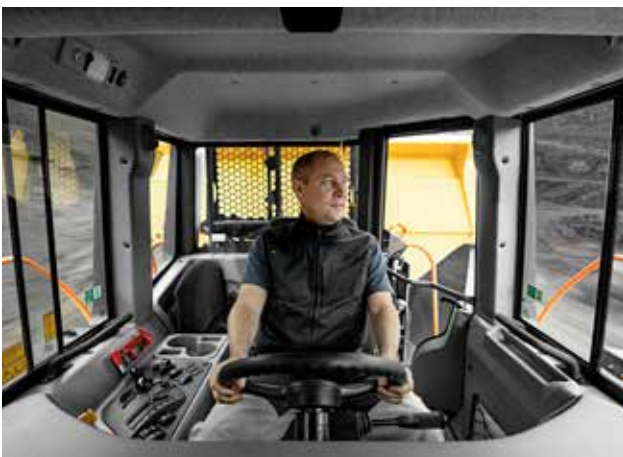

## Safety

A number of safety features such as superior visibility and efficient lighting help to keep the operator and people working around the machine safe in the most demanding working environments – whether it's the operator, trainers, mechanics or site workers.



# Volvo A35G, A40G in detail

## Engine

V-ACT, 13 liter, 6-cylinder straight VGT (Variable Geometry Turbocharged) diesel engine with 4 valves per cylinder, overhead camshaft and electronically controlled unit injectors. It has wet replaceable cylinder liners and replaceable valve guides and valve seats.

The engine has cooled EGR (Exhaust Gas Recirculation) and exhaust after treatment with EAT-Muffler (Exhaust After treatment) including DOC (Diesel Oxidation Catalyst), DPF (Diesel Particulate Filter) and SCR (Selective Catalytic Reduction) with an electronically controlled UDS (Urea Dosing System).

T4f after treatment system features passive DPF regeneration with an AHI (After treatment Hydro carbon Injection) device as back up.

## A35G

Engine model	Volvo	D13J
Max power - SAE J1995 Gross	kW	329
	hp	447
at engine speed	r/min	1 900
Flywheel power - ISO 9249, SAE J1349 Net	kW	327
	hp	445
at engine speed	r/min	1 900
Max torque - SAE J1995 Gross	Nm	2 360
Max torque - ISO 9249, SAE J1349 Net	Nm	2 345
at engine speed	r/min	1 050
Displacement	l	12.8

## A40G

Engine model	Volvo	D13J
Max power - SAE J1995 Gross	kW	350
	hp	476
at engine speed	r/min	1 900
Flywheel power - ISO 9249, SAE J1349 Net	kW	347
	hp	472
at engine speed	r/min	1 900
Max torque - SAE J1995 Gross	Nm	2 525
Max torque - ISO 9249, SAE J1349 Net	Nm	2 500
at engine speed	r/min	1 050
Displacement	l	12.8

## Electrical system

All cables, sockets and pins are identified. Cables are enclosed in plastic conduits and secured to main frame. Halogen lights. Prewired for options. Connectors meet IP67 standard for water-proofing as necessary.

		A35G	A40G
Voltage	V	24	24
Battery	V	2x12	2x12
Battery capacity	Ah	2x170	2x170
Alternator	kW/A	3.396/120	3.396/120
Starter motor	kW	9	9

## Drivetrain

Torque converter with built-in lock-up function.  
Transmission: Fully automatic Volvo PowerTronic planetary transmission with nine forward gears and three reverse gears. The transmission has the ability to skip gears for fast and accurate gear selection.  
Dropbox: Volvo-developed, in-line design with high ground clearance and 100% longitudinal "dog clutch" type differential lock.  
Axles: Heavy duty, purpose built Volvo design with fully floating axle shafts, planetary type hub reductions and 100% dog clutch type diff-lock.  
Automatic traction control system (ATC).

		A35G	A40G
Torque converter		2.1:1	2.1:1
Transmission	Volvo	PT 2529	PT 2529
Dropbox	Volvo	IL2 ATC	IL2 ATC
Axles	Volvo	ARB H35	ARB H40

## Suspension

Front suspension: Three point suspension consisting of a-stay fitted to the frame structure by a spherical rubber bushing, shock absorbers with accumulators and cross stays.  
Rear suspension: 3-point bogie beam suspension consisting of a straddle-mounted bogie beam with maintenance free rubber bearings, flexible rubber pads, cross stays and a-stay.

## Brake System

Fully hydraulic, wet multiple disc brakes with enclosed, forced oil-cooled multiple discs on all wheels. Two circuit brake system. Complies with ISO 3450 at total machine weight.  
Circuit division: One circuit for front axle and one for bogie axles.  
Parking brake: Spring-applied disc brake acting on the trailer unit propeller shaft. When the parking brake is applied, the longitudinal differential locked.  
Retarder: Service brake retarder function and Volvo Engine Brake (VEB).

## Steering System

Hydro-mechanical articulated steering, self compensating design.  
Two double-acting steering cylinders.  
Steering angle: 3,4 steering wheel turns lock-to-lock,  $\pm 45^\circ$ .  
Steering system, including secondary steering fulfills ISO 5010.



<b>Chassis</b>			
Frames: box type, heavy duty. High strength steel, robot welded. Rotating hitch: 100% maintenance free, fully sealed, with permanently greased tapered roller bearings.			

<b>Cab</b>			
Mounted on rubber pads. Ergonomically designed. Easy entry and exit. Wide angle forward view. Operator centrally positioned above the front axle. Adjustable operators seat with retractable seat belt. Tilt/telescopic steering wheel. Ergonomically positioned controls. Filtered air. Optional climate control system. Operator communication system: Contronics. Large color display, user-friendly and easy-to-understand information, all vital machine functions are constantly monitored. Instructor seat with seat belt. Safety: ROPS/FOPS standards approved according to ISO3471, SAE J1040 / ISO3449, SAE J231.			

		<b>A35G</b>	<b>A40G</b>
Sound level in cab (ISO 6396) - LpA	dB(A)	72	72
External sound level (ISO 6395) - LwA	dB(A)	112	112
Internal sound level with sound kit: 70 dB(A) External sound level with sound kit: 110 dB(A)			

<b>Hydraulic system</b>			
Pumps: Four variable displacement piston pumps driven by the flywheel PTO. Two load-sensing used for steering and tipping and two electrical controlled used for fan, brake cooling and brake power supply. One ground-dependent piston pump for secondary steering mounted on the dropbox. Two return oil filters with magnetic cores provide effective oil filtration.			

		<b>A35G</b>	<b>A40G</b>
System max working pressure	MPa	26	26

<b>Dumping System</b>			
Patented Load and Dump Brake. Dumping Cylinders: two single stage double acting cylinders.			

		<b>A35G</b>	<b>A40G</b>
Tipping angle	°	72	70
Tipping time with load	s	12	12
Lowering time	s	10	10

<b>Body</b>			
-------------	--	--	--

		<b>A35G</b>	<b>A40G</b>
<b>Plate thickness</b>			
Front	mm	8	8
Sides	mm	11	11
Bottom	mm	14	14
Chute	mm	16	16
<b>Material</b>		HB450 steel	HB450 steel
Yield strength	N/mm <sup>2</sup>	1 150	1 150
Tensile strength	N/mm <sup>2</sup>	1 350	1 350

<b>Load Capacity</b>			
----------------------	--	--	--

		<b>A35G</b>	<b>A40G</b>
<b>Standard Body</b>			
Load capacity	kg	34 500	39 000
Body, struck	m <sup>3</sup>	16.6	18.4
Body, heaped 2:1	m <sup>3</sup>	21.2	24
<b>With overhung tailgate</b>			
Body, struck	m <sup>3</sup>	17	18.8
Body, heaped 2:1	m <sup>3</sup>	22.1	24.7

# Specifications

## REFILL CAPACITIES

	A35G	A40G
Crankcase	50	50
Fuel tank	480	480
Cooling system	44	44
Brake cooling system	188	188
Transmission	43	43
Dropbox	9	9
Axles, front/bogie	25/51	26/53
Hydraulic tank	174	174
DEF/AdBlue®	39	39

®registered trademark of the Verband der Automobilindustrie e.V. (VDA)

## OPERATING WEIGHT UNLOADED

	A35G	A40G
Tires	26.5R25*	29.5R25**
Front	15 950	16 200
Rear	13 000	13 700
Total	28 950	29 900
Payload	34 500	39 000

Operating weight includes all fluids and operator

\*) A35G with tires 775/65R25, add 200 kg /axle

\*\*) A40G with tires 875/65R25, add 300 kg /axle

## SPEED

	A35G	A40G
<b>Forward</b>		
1	5.9	5.8
2	8.6	8.5
3	10.3	10.4
4	15.2	15
5	21.9	21.6
6	27.7	27.3
7	36.6	36.1
8	48.5	47.8
9	57	57
<b>Reverse</b>		
1	6.6	6.5
2	9.5	9.4
3	18	18

## TOTAL WEIGHT

	A35G	A40G
Tires	26.5R25*	29.5R25**
Front	19 100	20 200
Rear	44 350	48 700
Total	63 450	68 900

\*) A35G with tires 775/65R25, add 200 kg /axle

\*\*) A40G with tires 875/65R25, add 300 kg /axle

## GROUND PRESSURE

	A35G	A40G	A35G	A40G
Tires	26.5R25	29.5R25	775/65R25	875/65R25
<b>Unloaded</b>				
Front	132	111	115	98
Rear	54	47	48	42
<b>Loaded</b>				
Front	158	139	138	121
Rear	183	167	160	146

## Excavator PASS MATCHING

	EC380	EC480	EC750
<b>Number of passes</b>			
A35G	9	7	5
A40G	10	8	5

Well matched, 4-6 buckets.

Excavator under capacity, 7 buckets or more.

Excavator undersized for optimum match.

## Wheel loader PASS MATCHING

	L150	L180	L220	L250	L350
<b>Number of passes</b>					
A35G	5	4	4	3	3
A40G	5	5	4	4	3

Well matched, 2-3 buckets.

Loader under capacity, 4 buckets or more.

Loader undersized for optimum match, reach might be an issue.



**DIMENSIONS**

Pos	Unit	A35G	A40G
A	mm	11 180	11 263
A <sub>1</sub>	mm	5 476	5 476
A <sub>2</sub>	mm	6 241	6 404
B	mm	5 568	5 844
C	mm	3 547	3 599
C <sub>1</sub>	mm	1 772	1 772
D	mm	3 100	3 100
D <sub>1</sub>	mm	2 942	2 942
E	mm	1 277	1 277
F	mm	4 578	4 518
G	mm	1 820	1 940
H	mm	1 683	1 706
I	mm	650	495
J	mm	3 014	3 132
K	mm	2 304	2 435
L	mm	890	822
M	mm	7 236	7 265
N	mm	8 866	8 957
N <sub>1</sub>	mm	4 416	4 327
O	mm	3216	3 430
P	mm	2 902	3 118
Q	mm	2 553	2 820
R	mm	564	613
R <sub>1</sub>	mm	652	701
S	mm	2 423	2 651
T	mm	3 382	3 427
U	mm	3 498	3 546
V	mm	2 534	2 636
W	mm	3 221	3 403
X	mm	500	553
X <sub>1</sub>	mm	592	645
X <sub>2</sub>	mm	738	788
Y	mm	2 534	2 636
Z	mm	3 221	3 403
a <sub>1</sub>	°	23.6	24.3
a <sub>2</sub>	°	72	70
a <sub>3</sub>	°	45	45

A35G: Unloaded machine with 26.5R25

A40G: Unloaded machine with 29.5R25

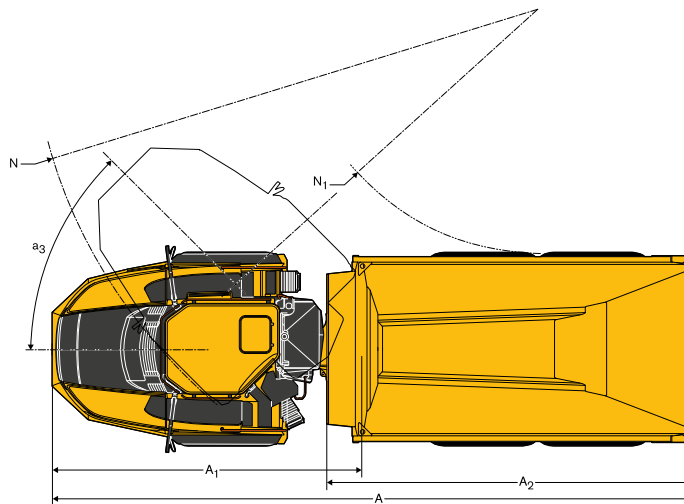
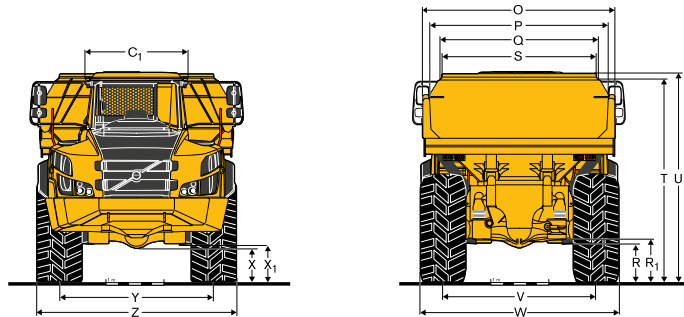
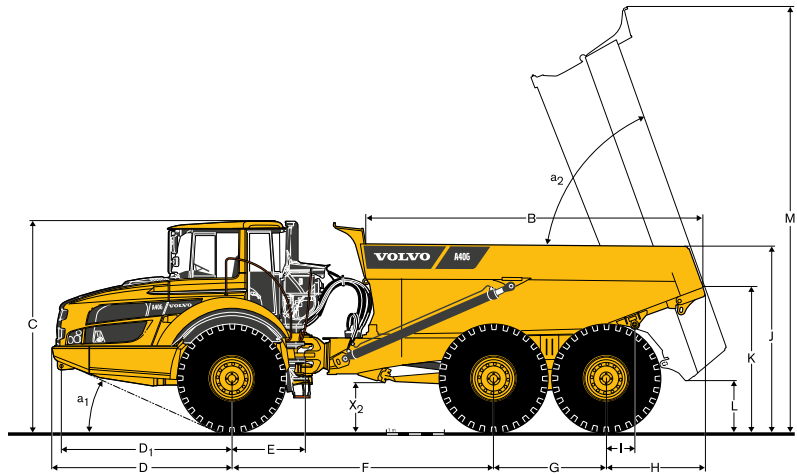

# Equipment

STANDARD EQUIPMENT		
	A35G	A40G
<b>Engine</b>		
Direct injected, electronically controlled, turbocharged, intercooled	•	•
Grouped oil filters, for ease of change	•	•
Preheater for easier cold starts	•	•
VEB (exhaust retarder EPG + compression brake)	•	•
<b>Tires</b>		
26.5R25	•	–
29.5R25	–	•
<b>Drivetrain</b>		
6x4 and 6x6 automatically engaged drive modes	•	•
Dog clutch type 100% diff-locks in all axles	•	•
Full automatic transmission	•	•
Dropbox with longitudinal diff-lock	•	•
Torque converter with automatic lock-up	•	•
<b>Electrical system</b>		
120 A alternator	•	•
Battery disconnect switch	•	•
Extra 24 V socket for lunch cooler	•	•
Lights:	•	•
Back-up light	•	•
Brake lights	•	•
Cab lighting	•	•
Direction indicators	•	•
Headlights	•	•
Instrument lighting	•	•
Parking lights	•	•
Rear lights	•	•
<b>Brake System</b>		
Hill assist	•	•
Load & Dump Brake	•	•
Retarder pedal	•	•
Parking brake on propeller shaft	•	•
Two circuit, fully hydraulic, wet discs on all axles	•	•
<b>Body</b>		
Body prepared for exhaust heating and optional equipment	•	•
<b>Safety</b>		
Anti-slip steps and platforms	•	•
Dump body lock	•	•
Handrails on steps and platforms	•	•
Hazard lights	•	•
Horn	•	•
Protective grill for cab rear window	•	•
Rear-view mirrors	•	•
Retractable 3-inch safety belt	•	•
ROPS/ FOPS protected Care Cab	•	•
Secondary steering	•	•
Steering joint lock	•	•
Windshield washers	•	•
Windshield wipers with interval function	•	•
Dump support system	•	•

STANDARD EQUIPMENT		
	A35G	A40G
<b>Comfort</b>		
ACC control panel	•	•
Ashtray	•	•
Cab heater with filtered fresh air and defroster	•	•
Can holder /storage tray	•	•
Cigarette lighter	•	•
Instructor seat with seat belt	•	•
Overhead console for radio	•	•
Sliding window	•	•
Space for lunch cooler	•	•
Storage box	•	•
Sun visor	•	•
Tilt/telescopic steering wheel	•	•
Tinted glass	•	•
<b>Operator information interface</b>		
Gauges:	•	•
Brake pressure	•	•
Fuel	•	•
Speedometer	•	•
Tachometer	•	•
Wet disc brakes cooling oil temperature	•	•
<b>Warning lights grouped and easy to read</b>		
Central warning (3 levels) for all vital functions	•	•
<b>Central positioned information display</b>		
Automatic pre-start checks	•	•
Clock	•	•
Hour meter	•	•
Operational information, easy-to-navigate menu	•	•
Troubleshooting diagnostics	•	•
<b>Exterior</b>		
Front mudguard wideners and rear mudflaps	•	•
<b>Service and Maintenance</b>		
Electrical engine hood and belly plate	•	•
Machine Tracking Information System MATRIS	•	•
Service platform integrated in the front grill	•	•
Tool box	•	•
<b>OPTIONAL EQUIPMENT</b>		
	A35G	A40G
<b>Engine</b>		
Air filter, heavy duty, EON	•	•
Engine heater, 120 V, USA	•	•
Engine heater, 240 V	•	•
Engine heater, diesel (Eberspächer)	•	•
Engine auto shutdown	•	•
Engine shutdown timer	•	•
External emergency engine stop	•	•
Fuel filter, extra	•	•
High engine idle speed	•	•
<b>Tires</b>		
775/65R25	•	–
875/65R25	–	•



OPTIONAL EQUIPMENT		
	A35G	A40G
<b>Electrical system</b>		
Headlights, LED	•	•
Warning beacon, LED	•	•
Working lights, halogen	•	•
Working lights, LED	•	•
Entrance light	•	•
Anti-theft system (pin code)	•	•
Rear view camera	•	•
Reverse alarm	•	•
CAN-BUS interface, extra	•	•
<b>Cab</b>		
Noise reduction kit (fulfils 2000/14/EC)	•	•
Anchorage, operator's manual	•	•
Cab heating/ventilation timer	•	•
Cable kit, for cab heater 240 V	•	•
HEPA cab air filter	•	•
Bluetooth radio kit	•	•
Rear view mirrors, adjustable, el.heated	•	•
Seat belt XXL, non-retractable	•	•
Sun blinds, side windows	•	•
Universal key	•	•
Air suspended, heated, fully adjustable seat	•	•
Armrest for operator seat	•	•
Headrest for operator seat	•	•
Low profile cab	•	•

OPTIONAL EQUIPMENT		
	A35G	A40G
<b>Body</b>		
Body exhaust heating	•	•
Front spillguard, extra	•	•
Side extension, 200 mm / 7.9 in	•	•
Side extension, light material	•	•
Tailgate, overhung, linkage-operated	•	•
Tailgate, overhung, wire-operated	•	•
Tailgate, underhung	•	•
Wear plates, 450 HB	•	•
Underground body	•	•
<b>Safety</b>		
Fire suppression system	•	•
Warning triangle	•	•
First aid kit and fire extinguisher	•	•
Fire extinguisher	•	•
Wheel chocks	•	•
<b>Service and Maintenance</b>		
Lube system, standard machine	•	•
Lube system, tailgate	•	•
Lubrication hose, ground level greasing	•	•
Tool kit	•	•
<b>Other</b>		
Siberian kit -40°C	•	•
On board weighing (OBW)	•	•
Arctic oil kit	•	•
CareTrack	•	•
Fast fuelling system	•	•
Jump start connector, NATO -type	•	•
Frame extension	•	•

## SELECTION OF VOLVO OPTIONAL EQUIPMENT

**Entrance light**



**Fast fuelling**



**LED lighting**



**On board weighing**



**Heavy duty air filter**

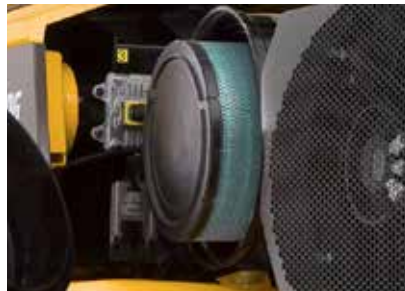

**Volvo fire suppression system**



Not all products are available in all markets. Under our policy of continuous improvement, we reserve the right to change specifications and design without prior notice. The illustrations do not necessarily show the standard version of the machine.

**VOLVO**

**Volvo Construction Equipment**

[www.volvoce.com](http://www.volvoce.com)