

VOLVO WHEEL LOADER

L500



- **Engine output SAE J1995:**
gross 74,6 kW (101.5 hp)
ISO 9249, SAE J1349:
net 74,0 kW (101 hp)
 - **Operating weight:** 8.2–9.4 t
18,080–20,720 lb
 - **Bucket volume:** 1,2–3,9 m³
1.6–5.1 yd³
 - **High performance – low emission**
 - **Hydraulically driven cooling fan**
 - **Hydrostatic transmission with kick-down function**
 - **Wet disc brakes**
 - fully sealed oil-circulation
 - cooled, outboard mounted
 - **Torque Parallel Linkage**
 - High breakout torque throughout the working range
 - Excellent parallel lift-arm action
 - **Care Cab II**
 - 2nd generation Care Cab pressurized cab with high comfort and safety
 - **Contronic II**
 - 2nd generation monitoring system
 - **Load-sensing working hydraulics and steering system**
 - **Pilot-operated working hydraulics**
- Optional equipment**
- Power take-off for hydraulically powered attachments
 - Boom Suspension System
 - Comfort Drive Control
- Other options, see back page**

VOLVO



SERVICE

The Contronic II monitoring system provides information on scheduled service intervals and machine condition. Minimizes time required for troubleshooting.

Service accessibility: Large, easy-to-open service doors with gas struts. Radiator easy to clean.

Refill capacities .. l	US gal	Refill capacities .. l	US gal
Fuel tank	180 48	Gearbox	7 1.8
Engine coolant ...	27 7.1	Engine oil	11 2.9
Hydraulic tank	65 17.2	Axle front / rear ...	22/22 5.8/5.8



ENGINE

The engine offers high torque and quick response at low rpm. The machine operates efficiently at low engine speeds, which contributes to good fuel economy, less noise, reduced wear and longer life.

Engine: High performance – low emission, 4-stroke, 4-cylinder in-line diesel engine with direct injection and turbocharger. Dry replaceable cylinder liners.

Air cleaning: three-stage.

Cooling system: Hydraulically driven fan

Engine TD40 GJE			
Max. power at	36,7 r/s	2 200 rpm	
SAE J1995 gross	74,6 kW	101,5 hp	
ISO 9249, SAE J1349 net	74,0 kW	101 hp	
Max. torque at	23,3 r/s	1 400 rpm	
SAE J1995 gross	403 Nm	297 lbf ft	
ISO 9249, SAE J1349 net	397 Nm	292 lbf ft	
Displacement	4,0 l	244 in³	

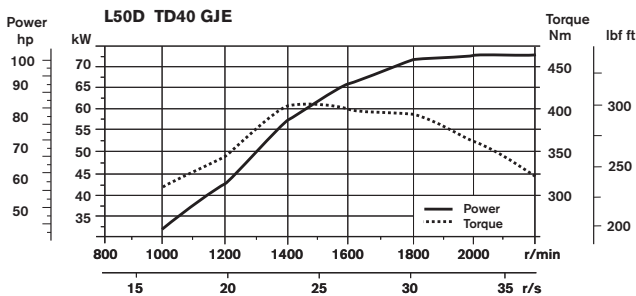

ELECTRICAL SYSTEM

Contronic II monitoring system with increased function control and capability to store data for analysis. Electrical system with circuit boards, well protected by fuses. The system is pre-wired for installation of optional equipment.

Central warning system: Central warning light for the following functions (buzzer with gear engaged): Engine oil pressure, hydrostatic charge pressure, gear box oil pressure, brake pressure, parking brake applied, hydraulic oil level, steering pressure, coolant temperature, gear box temperature, engine overspeeding, transmission overspeeding, computer malfunction, hydraulic oil temperature.

Voltage	24 V
Batteries	2x12 V
Battery capacity	2x105 Ah
Cold cranking capacity, ea	690 A
Reserve capacity, ea	185 min
Alternator rating	1 680 W / 60 A
Starter-motor output	4 kW 5,4 hp



DRIVETRAIN

The drivetrain and working hydraulics are well-matched to each other and of reliable design. Quick acceleration increases productivity.

Hydrostatic transmission: The transmission consists of a hydraulic pump, hydraulic motor (both with variable displacement) and a two-stage Volvo Power Shift gearbox, which is controlled by the gear selector or temporarily via a kick down function.

Axes: Volvo, fully floating axle shafts with planetary-type hub reductions. Cast-steel axle housing. Fixed front axle and oscillating rear axle. 100% differential lock on front axle (option).

Speeds	Low range	High range
	km/h	mph
Max. forward / reverse	0-19 0-11.8	0-41 0-25.5
Locked max. displacement	0-4.6 0-2.9	0-10.8 0-6.7
Measured with tires	17.5 R25	
Front and rear axle	Volvo / AWB 10	
Oscillation, rear axle	±12°	
Ground clearance at		
12° oscillation	365 mm	14.4 in



BRAKE SYSTEM

A simple and reliable brake system ensures high availability and safety. Self-adjusting oil-circulation-cooled wet disc brakes give long service intervals. Brake wear indicator and brake test in Contronic II are included in the brake system.

Service brakes: Volvo dual-circuit system with nitrogen-charged accumulators. Outboard mounted, fully hydraulic operated, fully sealed, oil-circulation cooled disc brakes.











Parking brake: Mechanically operated drum brake on front axle input shaft. Electro-hydraulically operated (option).

Secondary brake: Either of the service brake circuits or the parking brake fulfills the safety requirements.

Standards: The brake system complies with the requirements of ISO 3450, SAE J1473.

Number of discs/wheel	1
Number of accumulators	3
Volume, each	0,5 l 30.5 in³

OPERATIONAL DATA VOLVO L50D





	GENERAL PURPOSE						GRADING	LIGHT MATERIAL		
										
Tires 17.5 R25 L2	Bolt-on edge	Bolt-on edge	Bolt-on edge	Bolt-on edge	Teeth & segments	Teeth & segments		Bolt-on edge	Bolt-on edge	Bolt-on edge
Volume, heaped ISO/SAE	1,5	1,5	1,3	1,3	1,4	1,4	1,6	2,2	2,2	3,9
	2.0	2.0	1.7	1.7	1.8	1.8	2.1	2.9	2.9	5.1
Volume at 110% fill factor	1,7	1,7	1,4	1,4	1,5	1,5	–	2,4	2,4	4,3
	2.2	2.2	1.8	1.8	2.0	2.0	–	3.1	3.1	5.6
Static tipping load, straight	5 820	5 550	5 910	5 640	5 940	5 670	4 800	5 570	5 260	4 810
	12,830	12,230	13,040	12,430	13,090	12,500	10,580	12,290	11,590	10,610
at 35° turn	5 220	4 970	5 820	5 060	5 340	5 080	4 280	4 990	4 690	4 260
	11,510	10,960	11,720	11,160	11,770	11,200	9,440	11,000	10,340	9,390
at full turn	5 050	4 800	5 140	4 880	5 160	4 910	4 130	4 820	4 520	4 090
	11,130	10,590	11,330	10,760	11,380	10,820	9,110	10,620	9,970	9,030
Breakout force	60,7	56,7	65,8	61,0	64,1	59,7	40,9	49,1	45,9	35,8
	13,640	12,740	14,787	13,730	14,420	13,410	9,190	11,050	10,310	8,050
A	8 530	6 590	6 440	6 510	6 620	6 690	6 950	6 750	6 830	7 230
	21'5"	21'8"	21'2"	21'4"	21'9"	21'11"	22'10"	22'2"	22'5"	23'8"
E	930	990	840	910	1 030	1 100	1 230	1 160	1 240	1 620
	3'0"	3'3"	2'9"	3'0"	3'5"	3'7"	4'0"	3'10"	4'1"	5'4"
H*)	2 840	2 790	2 890	2 850	2 780	2 740	2 470	2 690	2 620	2 350
	9'4"	9'2"	9'6"	9'4"	9'1"	9'0"	8'1"	8'10"	8'7"	7'9"
L	4 840	4 870	4 760	4 800	4 840	4 870	4 390	4 920	4 960	5 420
	15'10"	16'0"	15'8"	15'9"	15'10"	16'0"	14'5"	16'2"	16'3"	17'9"
M*)	980	1 030	920	970	1 070	1 130	1 130	1 170	1 210	1 490
	3'3"	3'5"	3'0"	3'2"	3'6"	3'8"	3'8"	3'10"	4'0"	4'11"
N*)	1 530	1 550	1 500	1 530	1 580	1 610	1 460	1 550	1 580	1 620
	5'0"	5'1"	4'11"	5'0"	5'2"	5'3"	4'9"	5'1"	5'2"	5'4"
V	2 300	2 300	2 300	2 300	2 300	2 300	2 500	2 380	2 380	2 500
	7'7"	7'7"	7'7"	7'7"	7'7"	7'7"	8'2"	7'10"	7'10"	8'2"
a ₁ clearance circle	10 650	10 670	10 610	10 630	10 700	10 720	11 240	10 840	10 900	11 230
	34'11"	35'0"	34'10"	34'10"	35'1"	35'2"	36'11"	35'7"	35'9"	36'10"
Operating weight	8 640	8 800	8 590	8 760	8 590	8 750	8 830	8 740	8 900	9 180
	19,060	19,410	18,950	19,310	18,950	19,300	19,480	19,270	19,620	20,240

*) at 45° tipping angle

BUCKET SELECTION CHART

The choice of bucket is determined by the density of the material and the expected bucket fill factor. The actual bucket volume is often larger than the rated capacity, due to the TP linkage features: • Open bucket design. • Very good roll back in positions. • Good bucket fill performance.

Example: Sand and gravel. Fill factor ~ 105%. Density 2695 lb/yd³. Result: The 1.8 yd³ bucket carries 2.0 yd³. For optimum stability, always consult the bucket selection chart.

Material	Bucket fill %		Material density		ISO/SAE bucket volume		Actual volume	
			t/m³	lb/yd³	m³	yd³	m³	yd³
Earth/Clay	~ 110		~ 1,8	~ 3030	1,2	1,6	~ 1,3	~ 1,7
			~ 1,5	~ 2530	1,4	1,8	~ 1,55	~ 2,0
			~ 1,3	~ 2190	1,6	2,1	~ 1,8	~ 2,3
Sand/Gravel	~ 105		~ 1,9	~ 3200	1,2	1,6	~ 1,3	~ 1,7
			~ 1,6	~ 2695	1,4	1,8	~ 1,5	~ 2,0
			~ 1,3	~ 2190	1,6	2,1	~ 1,7	~ 2,2
Aggregate	~ 100		~ 1,9	~ 3200	1,2	1,6	~ 1,2	~ 1,6
			~ 1,8	~ 3030	1,4	1,8	~ 1,4	~ 1,8
			~ 1,5	~ 2530	1,6	2,1	~ 1,6	~ 2,1
Rock	≤ 100		~ 1,7	~ 2865	1,2	1,6	~ 1,2	~ 1,6

The size of rock buckets is designed for optimal penetration and filling capability rather than the density of the material.

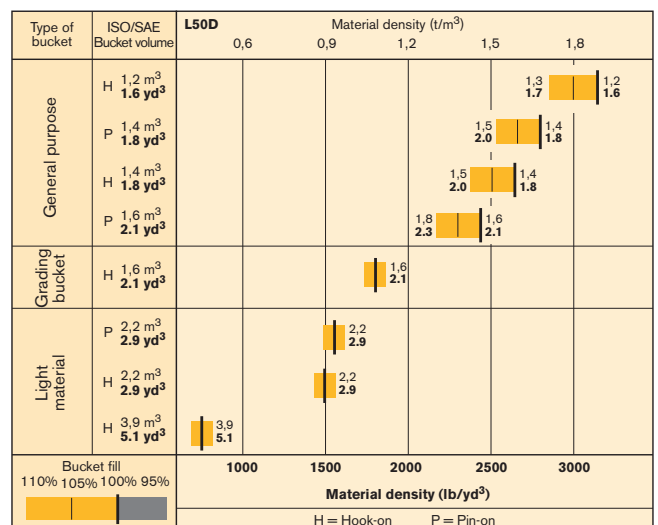

SUPPLEMENTAL OPERATING DATA

	Tires		Logging Counterweight		Axle-mounted Fenders	
	mm	in	mm	in	mm	in
	15.5 R25* L2					
Width over tires	mm	in	-60	-2		
Ground clearance	mm	in	-30	-1		
Tipping load, full turn	kg	lb	-190	-420	450	990
Operating weight	kg	lb	-320	-705	300	660
					+170	+375
					+150	+330

OPERATIONAL DATA & DIMENSIONS

Tires: 17.5 R25* L2

B	5 410 mm	17'9"
C	2 750 mm	9'0"
D	380 mm	1'3"
F	3 030 mm	9'11"
G	2 135 mm	7'0"
J	3 510 mm	11'6"
K	3 760 mm	12'4"
O	52°	
P	45°	
R	42°	
R ₁ *	48°	
S	90°	
T	40 mm	0'2"
U	430 mm	1'5"
X	1 750 mm	5'9"
Y	2 200 mm	7'3"
Z	3 060 mm	10'0"
a ₂	4 880 mm	16'0"
a ₃	2 680 mm	8'10"
a ₄	± 40°	

* Carry position SAE

Where applicable, specifications and dimensions are in accordance with ISO 7131, SAE J732, ISO 7546, SAE J742, ISO 5998, SAE J818, and ISO 8313.

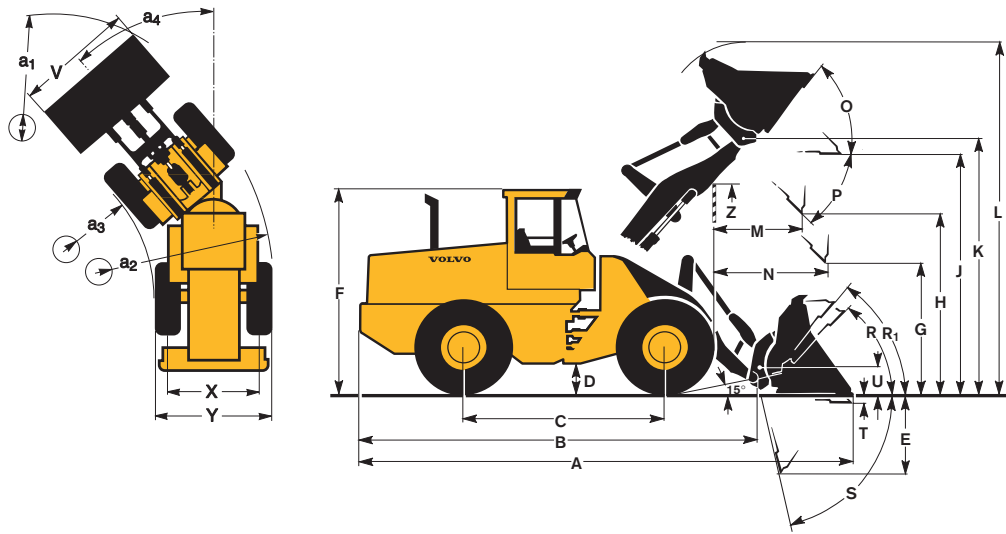

MATERIAL HANDLING ARM (Hook on)

Tires: 17.5 R25 L2

A*	1 120 kg	2,470 lb
B*	890 kg	1,960 lb
C*	720 kg	1,590 lb
D	2 830 mm	9'3"
E	2 180 mm	7'2"
F	1 590 mm	5'3"
G	3 280 mm	10'9"
H	4 310 mm	14'2"
I	5 450 mm	17'11"
J	570 mm	1'10"
K	710 mm	2'4"
L	860 mm	2'10"
M	2 290 mm	7'6"
N	3 320 mm	10'11"
O	4 440 mm	14'7"
P	1 470 mm	4'10"
Q	5 080 mm	16'8"
R	5 930 mm	19'5"
S	6 870 mm	22'6"

* Operating Load at full turn

Order No: 92007
Operating weight: 8570 kg (18,890 lb)

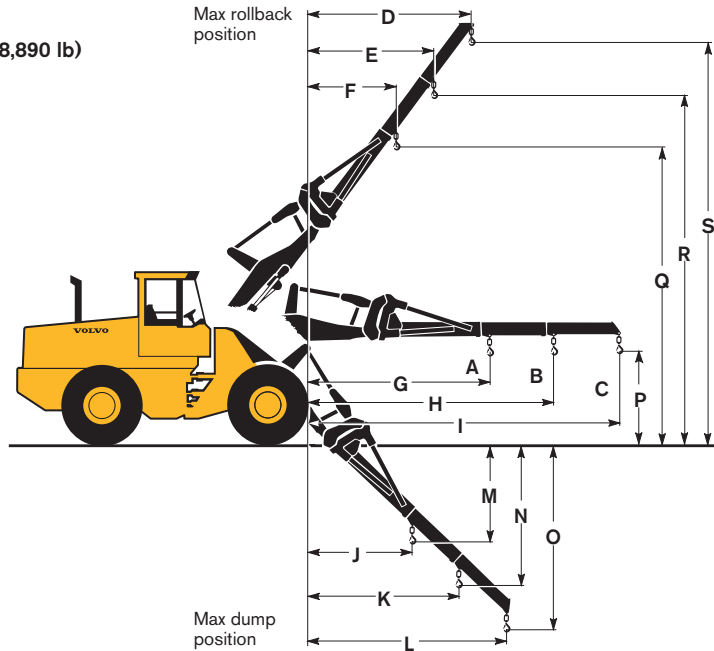

PALLET FORK (Hook on)

Tires: 17.5 R25 L2

A	820 mm	2'8"
B	1 570 mm	5'2"
C	20 mm	0'1"
D	1 710 mm	5'7"
E	3 530 mm	11'7"
F	720 mm	2'4"

Fork tine order no. (per tine): 93527
Length: 1200 mm 3'11"
Fork frame order no: 80041
Width: 1 500 mm 4'11"
Rated operating load*: 2 990 kg 6,590 lb
at load center distance: 600 mm 2'0"
Operating weight: 8 630 19,025 lb

* acc. std EN 474-3, firm and level ground

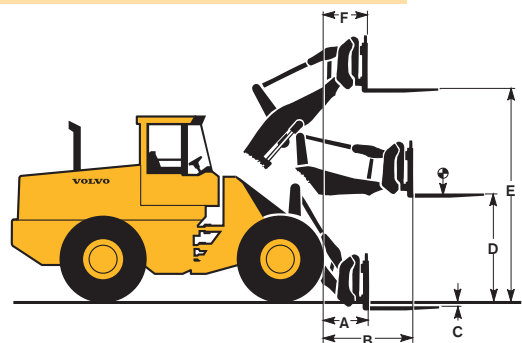



STEERING SYSTEM

Low effort steering provides fast work cycles. The power-efficient system results in good fuel economy, good directional stability and a smooth ride.

Steering system: Load-sensing hydrostatic articulated steering.

System supply: The steering system has priority feed from a load-sensing axial piston pump.

Pump: Axial piston pump with variable displacement.

Steering cylinders: Two double-acting cylinders.

Steering cylinders	2	
Bore	63 mm	2.48 in
Piston rod diameter	40 mm	1.57 in
Stroke	320 mm	12.60 in
Relief pressure	21 MPa	3046 psi
Articulation	±40°	



CAB

Care Cab II with easy entry and wide door opening. Inside of cab lined with noise-absorbent materials. Sound and vibration suppressing suspension. Good all-round visibility through large glass areas. Curved front windshield of green-tinted glass. Ergonomically positioned controls and instruments permit a comfortable operating position.

Instrumentation: All important information is centrally located in the operator's field of vision. Center console display for Contronic II monitoring system.

Heater and defroster: Heating element with filtered fresh air and fan with four speeds. Defroster vents for all window areas.

Operator's seat: Operator's seat with adjustable suspension and retractable seatbelt. The seat is mounted on a bracket on the rear cab wall. The forces from the retractable seatbelt are absorbed by the seat rails. Meets ISO/DSI 7096–1997.

Standard: The cab is tested and approved according to ROPS (ISO/CD 3471, SAE J1040), FOPS (3449, SAE J231), complies with Overhead guards for rider lifttrucks (ISO 6055) and Operator Restraint System (SAE J386).

Emergency exits	2	
Sound level in cab		
According to ISO 6396	LpA 71 dB (A)	
External sound level		
According to ISO 6395	LwA 103 dB (A)	
According to ISO 6395 ("Blauer Engel")	LwA 100 dB (A)	
Ventilation	9 m ³ /min	318 ft³/min
Heating capacity	11 kW	37,500 Btu/h
Air conditioning (optional equipment)	8 kW	27,300 Btu/h



HYDRAULIC SYSTEM

The Load-Sensing hydraulics deliver the exact amount of oil required for function used. At the same time, complete control of the hydraulics is achieved throughout the entire lifting range. The high capacity of the pump results in quick and smooth movements.

System supply: One load-sensing axial piston pump with variable displacement. The steering function always has priority.

Valves: Double-acting 2-spool valve. The main valve is controlled by a 2-spool pilot valve.

Lift function: The valve has four functions: raise, hold, lower and float. Inductive/magnetic automatic boom kickout can be switched on and off and is adjustable to any position between maximum reach and full lifting height.

Tilt function: The valve has three functions: rollback, hold and dump. Inductive/magnetic automatic tilt can be adjusted to the desired bucket angle.

Cylinders: Double-acting cylinders for all functions.

Filter: Full-flow filtration through 10 micron (absolute) filter cartridge.

Axial piston pump		
Relief pressure	26,0 MPa	3771 psi
Flow	120 l/min	31.7 US gpm
at	10 MPa	1450 psi
and engine speed	36,7 r/s	2 200 rpm
Pilot system		
Relief pressure	3,0 MPa	435 psi
Cycle times		
Raise*	5,4 s	
Dump*	1,1 s	
Lower, empty	3,0 s	
Total cycle time	9,5 s	

* with load as per ISO 5998 and SAE J818



LIFT ARM SYSTEM

The TP Linkage combines high breakout torque throughout the working range with parallel lift-arm action. These features, together with high lifting height and long reach, make the lift-arm system equally as good in bucket loading as in work with fork attachments and material handling arms.

Lift cylinder	2	
Bore	100 mm	3.9 in
Piston rod diameter	70 mm	2.8 in
Stroke	669 mm	26.3 in
Tilt cylinder	1	
Bore	125 mm	4.9 in
Piston rod diameter	70 mm	2.8 in
Stroke	434 mm	17.1 in

STANDARD EQUIPMENT

Engine

High Performance, low-emission
Volvo TD40 GJE
Dual fuel filters
Coolant filter
Cold starting aid
Air cleaner, dry type, dual element,
exhaust-aspirated precleaner
Coolant level, sight gauge
Muffler, spark arresting
Fan guard
Primary fuel filter with water
separator

Electrical System

24 V – prewired for optional
accessories
Alternator, 24 V, 60 A
Battery disconnect switch
Gauges:
• Fuel gauge
• Hourmeter
• Transmission temp
• Engine temp
Horn, electric
Instrument panel with symbols
Lights:
• Driving (2-Front), halogen head
lights with high/low beams
• Parking lights
• Stop/tail combination
(2 rear)
• Turn signals with separate hazard
warning switch
• Halogen working lights,
(2 front cab mounted, 2 rear)
• Instrument lighting
Reverse alarm (SAE J994)

Contronic II

Monitoring System, ECU with log and analysis system

Contronic II display
Engine shutdown to idle
• High engine coolant temperature
• Low engine oil pressure
• High transmission oil temperature
Neutral start feature
Brake test function
Test function for warning and
indicator lights
Warning and indicator lights:
• Alternator malfunction
• Oil pressure engine
• Oil pressure, transmission
• Brake pressure
• Parking brake applied
• Hydraulic oil level
• Hydraulic oil temperature
• Axle oil temperature
• Primary steering
• High beams
• Turn signals
• Rotating beacon
• Preheating coil
• Coolant temperature
• Transmission oil temperature
• Brake charging
• Air cleaner restriction
• Overspeed engine

Drivetrain

Hydrostatic transmission
Forward and reverse switch on
hydraulic control console
Tires 15.5 25* L2

Brake System

Wet, internal oil-circulation cooled,
outboard mounted disc brakes,
4-wheel, dual circuit brake system
Secondary brake system,
accumulator supplied
Parking brake

Cab

ROPS (SAE J1040) (ISO 3471),
FOPS (SAE J231) (ISO 3449)
Acoustic inner lining
Ashtray
Cab access steps and handrails
Cigarette lighter
Dual brake pedals
Lockable door (left side)
Heater/defroster/pressurized with 4
speed blower fan and cab air filter
Floor mat
Dome lights
2 interior rear-view mirror
2 exterior rear-view mirrors
Openable window right-hand side
Tinted safety glass
Retractable seat belt (SAE J386)
Steering wheel adjustable tilt and
telescopic
Adjustable lever console
Ergonomically designed operator's
seat with adjustable suspension
Storage compartment
Sliding window in door
Sun visor

Beverage holder
Windshield wipers front and rear
Intermittent function front
windshield wipers
Windshield washer front and rear
Service platforms with anti-slip
surfaces on front and rear fenders

Hydraulic System

Main valve, 2-Spool,
Pilot valve, 2-spool
Axial piston pump
Bucket leveler detent
Bucket leveler, automatic with
position indicator, adjustable
Boom lever detents
Boom kickout, automatic,
adjustable
Boom-lowering stopped engine
Hydraulic control lever safety latch
Hydraulic pressure test ports, quick
connect
Hydraulic fluid level, sight gauge
Hydraulic oil cooler
Test ports with quick-couplings

External Equipment

Attachment bracket, hydraulic, with
separate locking system
Fenders, front/rear
Isolation mounts: cab, engine,
gearbox, radiator
Lifting and tie-down lugs
Side panels, engine hood
Steering frame lock
Vandalism lock, provision for:
batteries, engine oil
Drawbar hitch
Fuel fill strainer

OPTIONAL EQUIPMENT *(Standard in certain markets)*

Service and Maintenance

Tool box, lockable
Automatic Lube System

Engine

Coolant pre-heater (120 V/1500 W)
or (240 V/1500 W)
Pre-cleaner, oil bath
Radiator corrosion protected
Pre-cleaner, turbo type

Electrical System

Working lights front, extra
Working lights rear, extra
Rotating beacon, amber with
collapsible mount

Drivetrain

100% differential lock, front axle
Speed control, inching pedal
Limited slip differential, rear

Cab

Sun blinds
Installation kit for radio
Hand throttle
AM/FM radio with tape deck
Air suspended operator seat
Air conditioner
Heated operator seat
Parking brake alarm
Armrest, left side
Retractable seat belt, 3 in,
extended length
Sliding window, right side
Open ROPS version
Ventilation filter for asbestos
environment

Hydraulic system

Hydraulic control, 3rd function
Hydraulic control, 4th function
Hydraulic control, 5th/6th function
Hydraulic power take off
Hydraulic single acting lifting
function

Lever detent, 3rd function
Boom Suspension System
Biodegradable hydraulic fluid
Single lever control

External Equipment

Logging counterweight 300 kg
660 lb
Fenders axle-mounted, rear
Fender rubber extensions

Other Equipment

Comfort Drive Control (CDC)
Slow moving vehicle sign
Secondary steering
Electro-hydraulically operated
parking brake

Tires

15.5 R25* 17.5-25
17.5 R25*

Protective Equipment

Guards for:
• Headlights
• Rear working lights
• Rear lights
• Windshield
Cover plate under cab

Attachments

Buckets:
• Straight with/without teeth
• Spade nose with/without teeth
• High tip
• Light material
Three piece, reversible bolt-on
cutting edge
Bolt-on and weld-on bucket teeth
Log grapples
Fork equipment
Material handling arm
Diagonal snow blade
Broom
Attachment rib kit

Under our policy of continuous product development and improvement, we reserve the right to change specifications and design without prior notice. The illustrations do not necessarily show the standard version of the machine.

VOLVO

**Volvo Construction Equipment
North America Inc.**

One Volvo Drive, Asheville, N.C. 28803-3447
Tel: 828-650-2090, Fax: 828-650-2508

Ref. No. 22 1 669 2318 US
Printed in USA 01/00 – 10,0 WLO
Biltmore Press, Asheville, NC