

## VOLVO WHEEL LOADER

# L330C

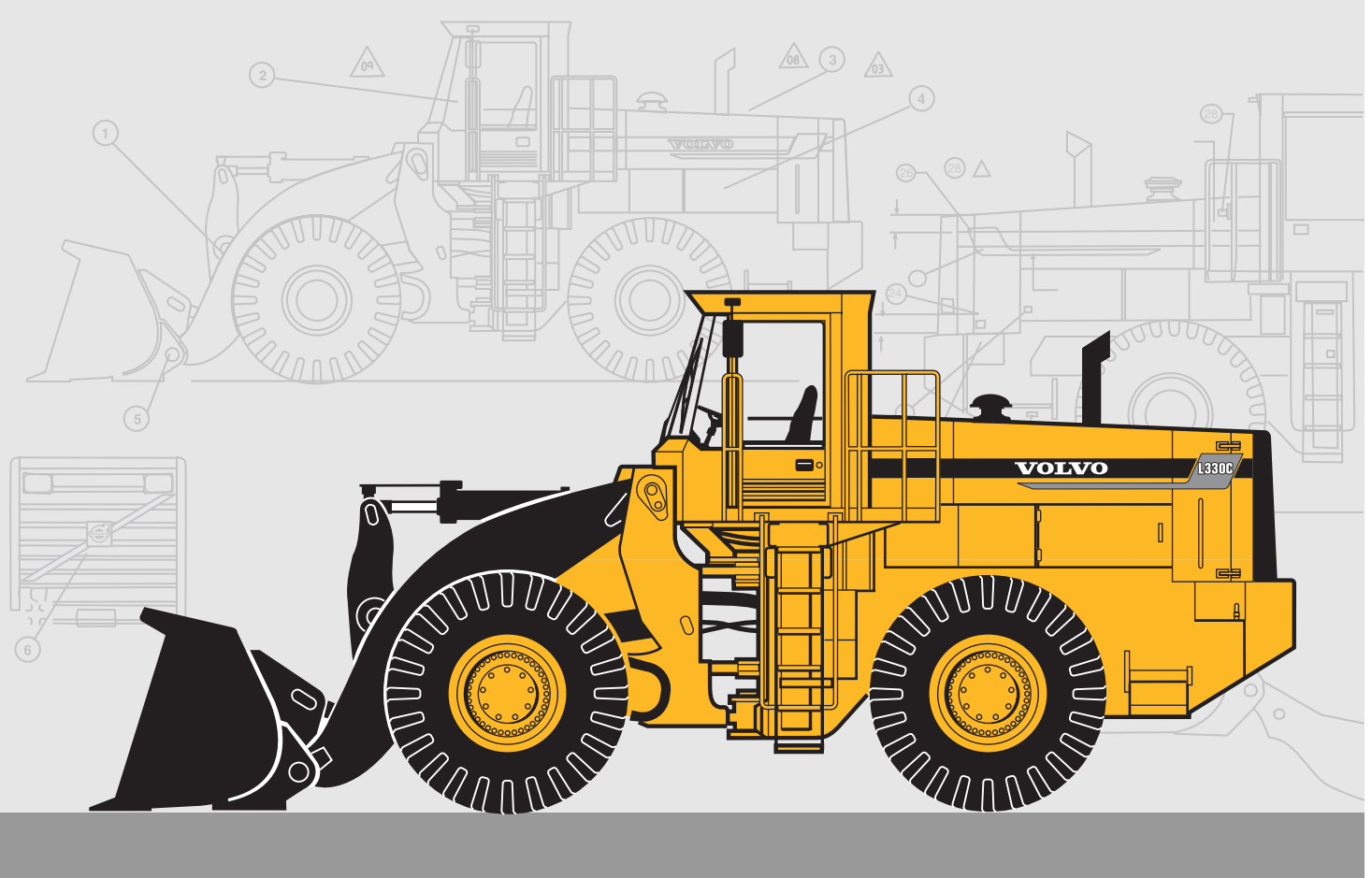

- **Engine output SAE J1349:**  
gross 370 kW (503 hp)  
net 366 kW (498 hp)

- **Operating weight:** 46,9–51,6 t

- **Buckets:** 6,1–12,7 m<sup>3</sup>

- **Volvo high performance low emission engine**, with excellent low rpm performance. The engine meets all known regulations regarding exhaust emission for off-road machines until year 2001

- **Wet disc brakes** – fully sealed, forced oil-cooled, outboard mounted

- **Posi-Torq** limited-slip differentials in front and rear axles

- **Care Cab** – pressurized cab with high comfort and safety

- **Contronic** monitoring system

- **Load-sensing hydraulic system** – working and steering hydraulics

- Pilot-operated working hydraulics

### Optional equipment

- Long boom

- Boom Suspension System

- Comfort Drive Control

# VOLVO



## SERVICE

Contronic monitoring system provides information on machine condition, routine maintenance schedules and minimizes time required for troubleshooting.

**Service accessibility:** Large, easy-to-open engine access doors with gas struts. Hinged radiator grille, fan and condenser. All routine service from ground level or steel platforms

Refill capacities	Engine oil .....	61 l
Fuel tank .....	Transmission .....	92 l
Engine coolant .....	Wheel hubs, ea. ....	20,8 l
Hydraulic tank .....	Differentials, ea. ....	68,1 l
Hydraulic system .....	Midmount bearing .....	4,7 l



## ENGINE

The high performance low emission engine delivers high torque and quick response at low engine rpm. This contributes to good fuel economy, lower noise, longer life and reduced impact on the environment.

**Engine:** High performance low emission, 6 cylinder, in-line, direct-injected, turbocharged and intercooled, 4-stroke diesel engine.

**Air Cleaning:** three stage

Model .....	Volvo TD 164 KAE
Output at .....	30,0 r/s (1800 r/min)
SAE J1349 .....	gross 370 kW (503 hp)
SAE J1349 .....	net 366 kW (498 hp)
Max. torque at .....	16,7 r/s (1000 r/min)
SAE J1349 .....	gross 2370 Nm
SAE J1349 .....	net 2330 Nm
Displacement .....	16,12 l

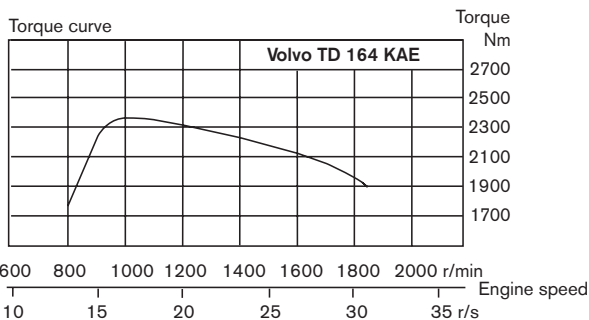

## ELECTRICAL SYSTEM

Contronic monitoring system with complete information on the status of the machine's various systems is standard. Electrical system with circuit board, mounted in the cab, is well protected by fuses. Prewired for optional equipment.

**Central warning:** Central warning lamp for the following functions: engine oil pressure, engine coolant temperature (with buzzer), transmission oil pressure, transmission oil temperature, brake pressure, parking brake (buzzer), front axle oil temperature. Engine shut down to idle.

Voltage .....	24 V
Batteries, series/parallel .....	4x12 V
Battery capacity, total .....	238 Ah
Cold cranking capacity, ea .....	1250 A
Reserve capacity, ea .....	320 min
Alternator rating .....	2240 W / 80 A
Starter-motor output .....	7,5 kW (10.0 hp)



## DRIVETRAIN

Drivetrain and working hydraulics well-matched to achieve optimum productivity. Dependable well proven design throughout the whole drivetrain.

**Torque converter:** Single-stage.

**Transmission:** Power shift, countershaft with single lever control. Directional and range modulation provide fast and smooth shifting.

**Shifting system:** Volvo Automatic Power Shift (APS II) with mode selector.

**Axles:** Fully floating axle shafts with planetary-type heavy duty hub reductions. Cast-steel axle housing. Fixed front axle and oscillating rear axle. Posi-Torq limited-slip differentials in front and rear axle.

Torque Converter .....	C9672
Transmission .....	C8421H
Torque multiplication .....	2,29:1
Speeds, max .....	
1 forward/reverse .....	6,6 km/h
2 forward/reverse .....	11,6 km/h
3 forward/reverse .....	19,9 km/h
4 forward only .....	34,2 km/h

Measured with tires .....	35/65R33 XLD D1* L-4
Front axle and rear axle .....	21D 5568
Oscillation, rear axle .....	±12 °
Total .....	564 mm



## BRAKE SYSTEM

Simple, reliable system ensures high availability and safety. Self-adjusting, forced oil-cooled wet disc brakes give long service life.

**Service brakes:** Fully hydraulic operated system with outboard mounted oil-cooled, wet disc brakes at each wheel. Filtered and cooled oil circulates through each brake when engine is running. Transmission declutch during braking can be pre-selected by a switch on the instrument panel.

**Parking brake:** Dry disc type mounted on front axle input shaft. Spring applied, electro-hydraulically released via a switch on the instrument panel. Applies automatically when the key is turned off.

**Secondary brake:** Dual circuit axle-by-axle system. Actuated by service brake pedal. Low pressure alarm. Dead engine braking capability provided by two nitrogen-charged accumulators.

**Pump:** One variable-flow axial piston pump common with the pilot system.

**Standards:** The brake system complies with the requirements of ISO 3450, SAE J1473.

Brake pressure setting .....	6,55 MPa
Number of discs/wheel .....	6
Number of accumulators .....	2
Accumulators, volume each .....	4,0 l



## STEERING SYSTEM

Low-effort hydrostatic, load-sensing steering system gives short work cycle times. Power-efficient system provides good directional stability and smooth ride and contributes to good fuel economy.

**System supply:** The steering system is fed by two load-sensing variable-flow axial piston pumps. The pumps will also feed the main hydraulic system, but steering system flow always has priority.

**Cylinders:** Double-acting cylinders with frame mounted rubber cushioned steer stops.

Steering cylinder .....	2
Bore .....	125 mm
Piston rod diameter .....	70 mm
Stroke .....	493 mm
Relief pressure .....	21,5 MPa
Max. flow .....	370 l/min.
Articulation .....	± 35°

**Standards:** Steering system complies with ISO 5010 and SAE J1511



## CAB

Care Cab with easy entry and wide door opening. Lined with sound-absorbent material. Sound and vibration-suppressing suspension. Good all-round visibility, large glass areas. Curved windshield of laminated, green-tinted glass. Ergonomically located controls and instruments permit a comfortable operating position.

**Instrumentation:** All important information is readily visible to the operator is easily visible in front of him. Cab display for Contronic monitoring system.

**Heater/defroster/air conditioner:** Heating element and air conditioner with filtered fresh air and four-speed fan. Defroster outlets for all windows. Cab air can be recirculated.

**Operator's seat:** Spring suspended, adjustable operator's seat with belt. The seat is mounted on a bracket on the rear wall. The force from the belt is absorbed by the seat rails.

**Standards:** Tested and approved according to the following standards: ROPS (ISO 3471, SAE J1040), FOPS (ISO 3449, SAE J231). Complies with (ISO 6055) and "Operator Restraint System" (SAE J386).

Emergency exits .....	2
Sound level in cab .....	
as per ISO 6394, max. ....	74 dB (A)
Exterior sound level	
ISO 6393 .....	LwA 115 dB (A)
Ventilation .....	10 m <sup>3</sup> /min
Heating capacity .....	11 kW
Air conditioning capacity .....	8 kW



## HYDRAULIC SYSTEM

Load-sensing hydraulics distribute exactly the quantity of oil required for the function used. Load-sensing system gives precise control of the hydraulics throughout the lifting range. High pump capacity provides quick and smooth movements.

**System supply:** Four load-sensing variable-flow axial piston pumps. Steering function always has priority from two of the pumps.

**Valve:** Twin double-acting 2-spool valves. The main valves are actuated by a pilot valve.

**Lift function:** The valve has four functions: raise, hold, lower and float. Inductive/magnetic automatic boom kickout can be switched on and off and is adjustable to any position between maximum reach and full lift height.

**Tilt function:** The valve has three functions: rollback, hold and dump. Inductive/magnetic automatic bucket positioner can be switched on and off.

**Cylinders:** Double-acting cylinders for each function.

**Filter:** Full-flow filtration through 20 micron (absolute) filter cartridge.

Main system	
Relief pressure .....	21,5 MPa
Flow .....	740 l/min
at .....	10 MPa
and engine speed .....	30,0 r/s (1800 r/min)
Pilot system	
Relief pressure .....	3,5 MPa
Cycle times	
Raise* .....	8,5 s
Dump* .....	1,8 s
Lower, empty .....	4,5 s
Total cycle time .....	14,8 s

\* with load as per ISO 5998 and SAE J818



## LIFT-ARM SYSTEM

The Z-bar system is a dependable linkage with good breakout qualities. Ideal as a primary production unit.

Lift cylinder .....	2
Bore .....	230 mm
Piston rod diameter .....	120 mm
Stroke .....	1170 mm
Tilt cylinder .....	2
Bore .....	190 mm
Piston rod diameter .....	90 mm
Stroke .....	808 mm

## OPERATIONAL DATA VOLVO L330C (STANDARD BOOM)

		HEAVY DUTY AND MATERIAL HANDLING							Material handling		
Tires 35/65R33 XLD D1 L-4 Michelin		Straight edge, STE	STE with teeth*	STE with BOE**	STE w/teeth* & wear caps	Spade nose, SPN	SPN with teeth*	SPN with BOE**	SPN w/teeth* & wear caps	Straight with BOE**	STE with BOE**
Volume, heaped	m <sup>3</sup>	6,6	6,6	6,9	6,9	6,6	6,6	6,8	6,8	7,3	8,3
Volume, struck	m <sup>3</sup>	5,6	5,6	5,9	5,9	5,6	5,6	5,8	5,8	6,4	7,1
Bucket weight	kg	4 510	4 940	5 030	5 270	5 070	5 490	5 640	5 820	4 700	4 940
Static tipping load, straight	kg	36 050	35 450	35 230	34 720	35 240	34 600	34 300	34 020	35 470	34 710
Static tipping load, at full turn	kg	31 830	31 210	31 000	30 470	30 990	30 340	30 040	29 760	31 250	30 500
Breakout force	kN	499,7	499,7	467,6	466,8	392,7	392,7	372,1	371,4	460,3	420,1
A	mm	9 960	10 320	10 080	10 360	10 350	10 720	10 470	10 760	10 100	10 260
L	mm	7 280	7 280	7 280	7 280	7 160	7 160	7 160	7 160	7 010	7 150
J	mm	4 690	4 690	4 650	4 640	4 690	4 690	4 650	4 640	4 650	4 630
H	mm	3 750	3 510	3 660	3 480	3 490	3 260	3 410	3 220	3 650	3 540
M	mm	1 700	1 980	1 740	1 940	2 000	2 280	2 040	2 250	1 760	1 860
N	mm	2 450	2 670	2 470	2 630	2 690	2 900	2 710	2 850	2 490	2 570
T	mm	90	90	130	140	90	90	130	140	130	140
E	mm	1 200	1 200	1 300	1 320	1 520	1 520	1 610	1 620	1 320	1 440
Operating weight	kg	47 910	48 340	48 430	48 670	48 470	48 900	49 040	49 230	48 100	48 340

Counterweight 1 included in operational data. Counterweight 1 may be used in material handling.

\*Teeth, Combi-parts C5T9. Dimensions measured to tips of teeth. Other teeth may affect dimensions differently.

\*\*BOE – Bolt-on edges.

Maximum grading angle = 46°

## BUCKET SELECTION CHART

The volume handled varies with the bucket fill and is often greater than indicated by the bucket's ISO/SAE volume. The table shows optimum bucket choice with regard to the material density.

Material	Bucket fill %	Density t/m <sup>3</sup>
Earth	100–115	1,4–1,6
Clay	110–120	1,4–1,6
Sand	100–110	1,6–1,9
Gravel	100–110	1,7–1,9
Rock	75–100	1,5–1,9

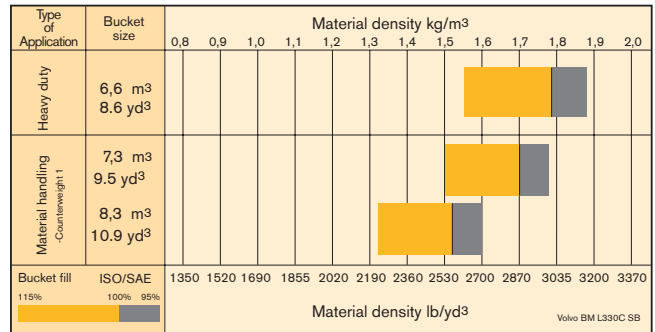

## BUCKET DIMENSIONS

Bucket dimensions		Straight edge, STE	STE with teeth*	STE with BOE**	STE w/teeth* & wear caps	Spade nose, SPN	SPN with teeth*	SPN with BOE**	SPN w/teeth* & wear caps	Straight with BOE**	STE with BOE**
b	mm	1 830	2 200	1 920	2 200	2 230	2 590	2 320	2 590	2 000	2 090
c	mm	1 820	1 820	1 860	1 860	1 790	1 790	1 830	1 830	1 850	1 890
d	mm	1 400	1 770	1 490	1 770	1 820	2 180	1 910	2 180	1 570	1 660
e	mm	3 850	3 850	3 850	3 850	3 900	3 900	3 900	3 900	3 830	3 830
V	mm	3 970	3 970	3 970	3 970	3 970	3 970	3 970	3 970	3 970	3 970
y	mm	65	65	65	65	65	65	65	65	65	65
a <sub>1</sub> clearance circle	mm	18 020	18 300	18 090	18 300	17 960	18 230	17 970	18 230	18 120	18 190

## OPERATIONAL DATA & DIMENSIONS (STANDARD BOOM)

**Tires 35/65R33 XLD D1 L-4 Michelin**

Where applicable, specifications and dimensions are in accordance with ISO 7131, SAE J732, ISO 7546, SAE J742, ISO 5998, SAE J818, ISO 8313.

Changes from the standard configuration may change machine dimensions and operating data. Operating weight is approximate and includes the bucket given in the table, ROPS canopy, cab, all standard equipment and counterweight 1.

B	8 320	mm
C	4 060	mm
D	550	mm
F	4 170	mm
F1	3 840	mm
F2	3 150	mm
F3	40	mm
G	2 135	mm
K	5 040	mm
O	66	°
P	45	°
R	44	°
R <sub>1</sub> *	51	°
S	57	°
U	400	mm
V	3 970	mm
X	2 720	mm
Y	3 630	mm
Z	4 140	mm
a <sub>2</sub>	8 250	mm
a <sub>3</sub>	4 620	mm
a <sub>4</sub>	±35	°

\* Carry position SAE

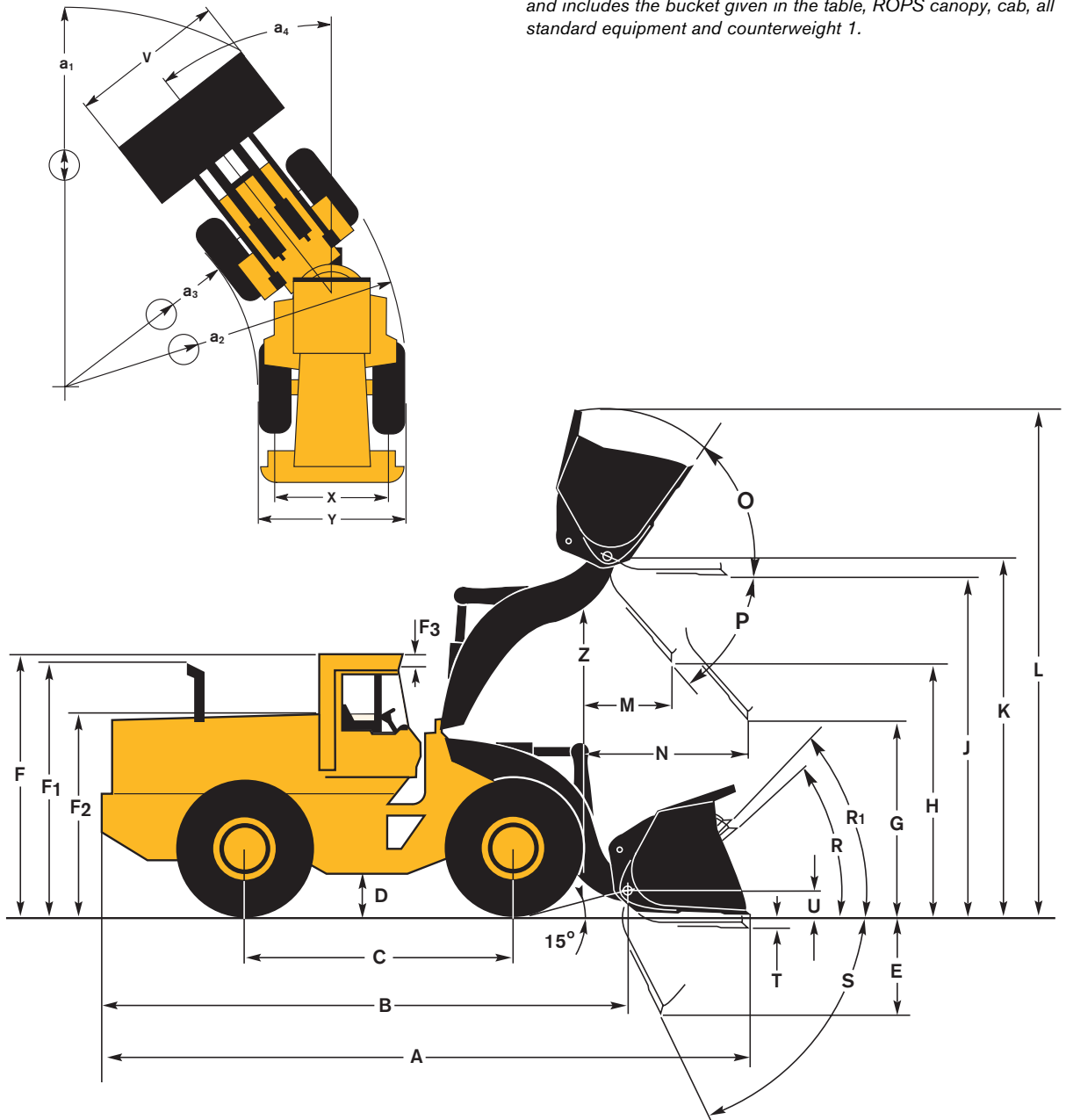

## BUCKET DIMENSIONS

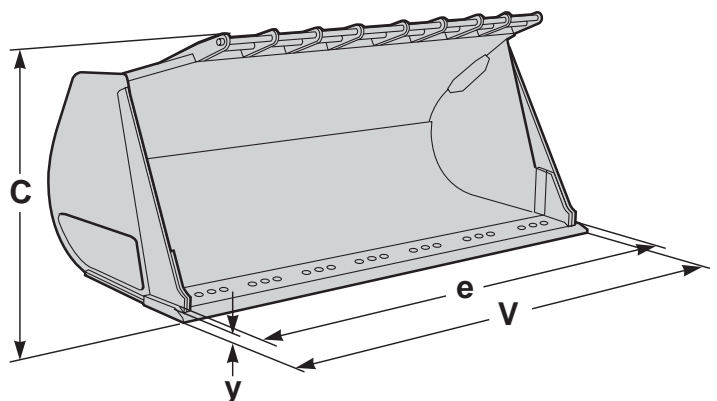
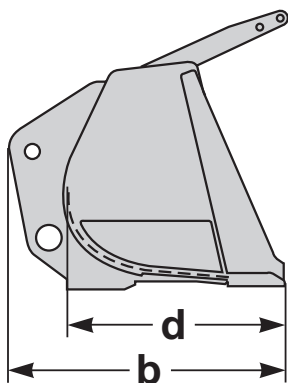

## SUPPLEMENTAL OPERATING DATA (STANDARD BOOM)

### Tires 35/65R33 XLD D1 L-4 Michelin and counterweight 1

SUPPLEMENTAL OPERATING WEIGHT		Change in operating weight	Change in static tipping load, straight	Change in static tipping load, full turn
Counterweight #1 (removal)	kg	-1 040	- 2 300	- 2 050
ROPS canopy (removal) (for shipping only)	kg	- 760		
Optional tires: 35/65-33 (30PR) L-4 Firestone/ 35/65-33 (36PR) L-4 Firestone	kg	+ 990	+ 740	+ 670
35/65-33 (30PR) L-4 Goodyear	kg	+ 785	+ 585	+ 530
35/65-33 (30PR) L-5 Firestone	kg	+ 1 480	+ 1 110	+ 1 010
35/65-33 (30PR) L-5 Goodyear	kg	+ 1 470	+ 1 100	+ 1 000
35/65R33 RL-5K* L-5 Goodyear	kg	+ 1 180	+ 880	+ 803
35/65R 33 XLD D2* L-5 Michelin	kg	+ 640	+ 410	+ 360
35/65R 33 X MINE L-5 Michelin	kg	+ 1 230	+ 940	+ 880

SUPPLEMENTAL OPERATING DIMENSIONS		Change in height dimensions	Change in width
Optional tires: 35/65-33 (30PR) L-4 Firestone/ 35/65-33 (36PR) L-4 Firestone	mm	+ 40	- 17
35/65-33 (30PR) L-4 Goodyear	mm	+ 10	- 7
35/65-33 (30PR) L-5 Firestone	mm	+ 40	- 25
35/65-33 (30PR) L-5 Goodyear	mm	+ 10	- 13
35/65R33 RL-5K* L-5 Goodyear	mm	+ 20	- 9
35/65R 33 XLD D2* L-5 Michelin	mm	+ 15	
35/65R 33 X MINE L-5 Michelin	mm	+ 33	

SUPPLEMENTAL SHIPPING DIMENSIONS		Height dimensions without ROPS canopy	Height dimensions
Lower center hinge – top of cab	mm	3 560	
Rear frame – top of cab	mm	3 550	
Bottom of planetary – top of cab	mm	3 530	
Bottom of differential – top of cab	mm	3 500	
Bottom of wooden wheels – top of cab	mm	3 730	
Bottom of wooden wheels – planetary	mm		200
Bottom of wooden wheels – differential	mm		235

## OPERATIONAL DATA VOLVO L330C (LONG BOOM)

		Heavy duty and material handling								
Tires 35/65R33 XLD D1 L-4 Michelin		Straight edge, STE	STE with teeth*	STE with BOE**	STE w/teeth* & wear caps	Spade nose, SPN	SPN with teeth*	SPN with BOE**	SPN w/teeth* & wear caps	STE w/BOE**
Volume, heaped	m <sup>3</sup>	6,1	6,1	6,4	6,4	6,1	6,1	6,3	6,3	12,7
Volume, struck	m <sup>3</sup>	5,0	5,0	5,2	5,4	5,2	5,2	5,4	5,4	10,2
Bucket weight	kg	4 350	4 770	4 850	5 110	5 060	5 490	5 630	5 820	5 860
Static tipping load, straight		35 290	34 700	34 300	33 930	33 230	32 630	32 350	32 080	31 840
Static tipping load, at full turn	kg	31 140	30 550	30 150	29 780	29 180	28 570	28 290	28 010	27 740
Breakout force	kN	558,3	558,3	520,7	520,1	395,9	395,9	376,5	375,7	361,2
A	mm	10 190	10 550	10 300	10 310	10 730	11 090	10 840	11 130	10 920
L	mm	7 500	7 500	7 500	7 500	7 550	7 550	7 550	7 550	7 770
J	mm	5 080	5 080	5 040	5 030	5 070	5 070	5 040	5 020	5 030
H	mm	4 260	4 040	4 180	4 170	3 920	3 690	3 840	3 650	3 790
M	mm	1 720	2 010	1 760	1 760	2 140	2 420	2 190	2 390	2 250
N	mm	2 680	2 910	2 710	2 700	3 010	3 220	3 040	3 180	2 990
T	mm	80	80	120	130	90	90	120	140	130
E	mm	1 030	1 030	1 120	1 130	1 430	1 430	1 520	1 530	1 580
Operating weight	kg	49 110	49 530	49 610	49 870	49 820	50 250	50 390	50 580	50 620

Counterweight 1+2 included in operational data. Counterweight 1+2 may be used in material handling.

\*Teeth, Combi-parts C5T9. Dimensions measured to tips of teeth. Other teeth may affect dimensions differently.

\*\*BOE – Bolt-on edges.

Maximum grading angle = 46°

## BUCKET SELECTION CHART

The volume handled varies with the bucket fill and is often greater than indicated by the bucket's ISO/SAE volume. The table shows optimum bucket choice with regard to the material density.

Material	Bucket fill %	Density t/m <sup>3</sup>
Earth	100–115	1,4–1,6
Clay	110–120	1,4–1,6
Sand	100–110	1,6–1,9
Gravel	100–110	1,7–1,9
Rock	75–100	1,5–1,9

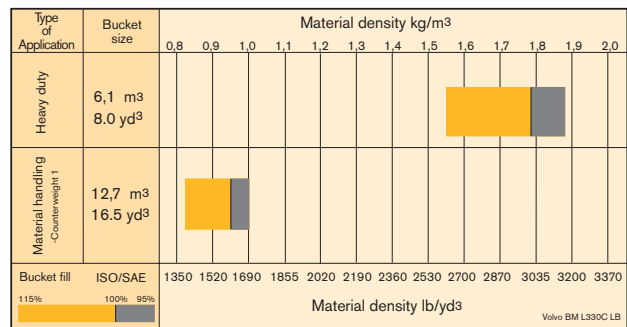

## BUCKET DIMENSIONS

Bucket dimensions		Straight edge, STE	STE with teeth*	STE with BOE**	STE w/teeth* & wear caps	Spade nose, SPN	SPN with teeth*	SPN with BOE**	SPN w/teeth* & wear caps	STE w/BOE**
b	mm	1 680	2 050	1 770	2 050	2 230	2 590	2 320	2 590	2 309
c	mm	2 030	2 030	2 070	2 070	2 070	2 070	2 110	2 110	2 325
d	mm	1 260	1 620	1 350	1 620	1 820	2 180	1 910	2 180	2 043
e	mm	3 850	3 850	3 850	3 850	3 900	3 900	3 900	3 900	4 371
V	mm	3 970	3 970	3 970	3 970	3 970	3 970	3 970	3 970	4 500
y	mm	65	65	65	65	65	65	65	65	65
a <sub>1</sub> clearance circle	mm	18 230	18 520	18 300	18 520	18 160	18 440	18 160	18 440	19 137



## OPERATIONAL DATA & DIMENSIONS (LONG BOOM)

**Tires 35/65R33 XLD D1 L-4 Michelin**

Where applicable, specifications and dimensions are in accordance with ISO 7131, SAE J732, ISO 7546, SAE J742, ISO 5998, SAE J818, ISO 8313.

Changes from the standard configuration may change machine dimensions and operating data. Operating weight is approximate and includes the bucket given in the table, ROPS canopy, cab, all standard equipment and counterweight 1+2.

B	8 700	mm
C	4 060	mm
D	550	mm
F	4 170	mm
F1	3 840	mm
F2	3 150	mm
F3	40	mm
G	2 135	mm
K	5 420	mm
O	66	°
P	45	°
R	44	°
R <sub>1</sub> *	51	°
S	52	°
U	520	mm
V	3 970/4 500	mm
X	2 720	mm
Y	3 630	mm
Z	4 330	mm
a <sub>2</sub>	8 250	mm
a <sub>3</sub>	4 620	mm
a <sub>4</sub>	±35	°

\* Carry position SAE

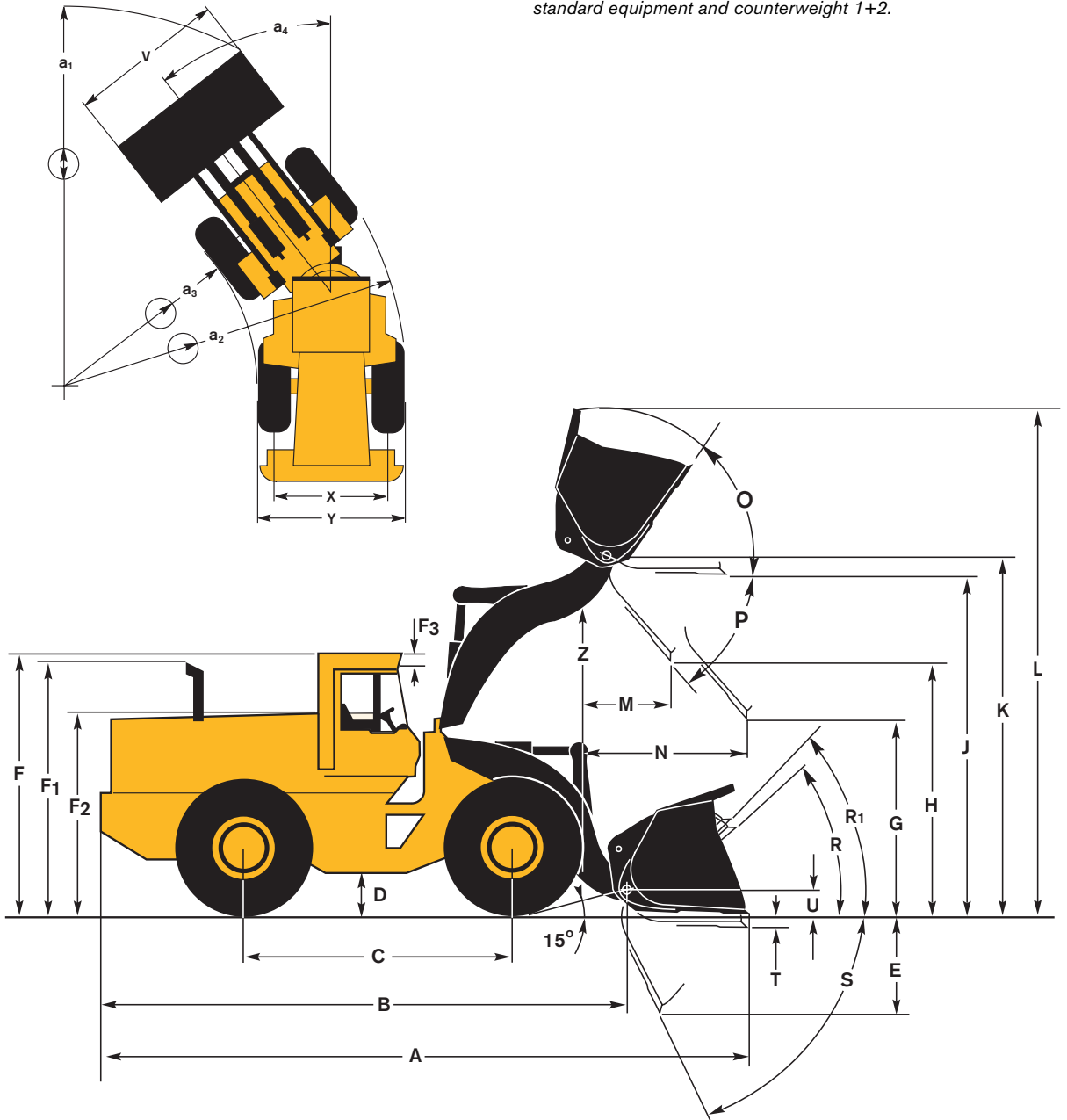

## BUCKET DIMENSIONS

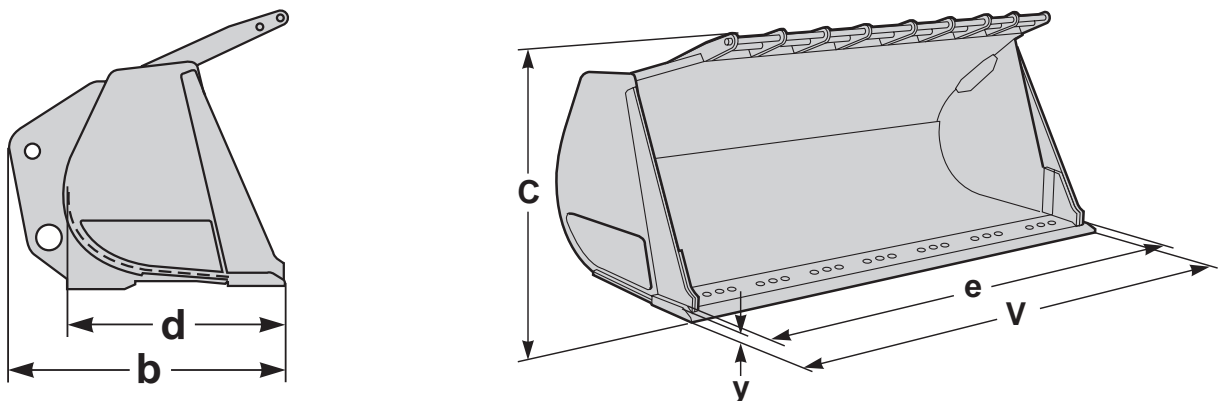



## SUPPLEMENTAL OPERATING DATA (LONG BOOM)

Tires 35/65R33 XLD D1 L-4 Michelin and counterweight 1+2

SUPPLEMENTAL OPERATING WEIGHT		Change in operating weight	Change in static tipping load, straight	Change in static tipping load, full turn
Counterweight #1 (removal) (for shipping only)	kg	-1 040		
Counterweight #2 (removal)	kg	- 1 040	- 2 140	- 1 900
ROPS canopy (removal) (for shipping only)	kg	- 760		
Optional tires: 35/65-33 (30PR) L-4 Firestone/ 35/65-33 (36PR) L-4 Firestone	kg	+ 990	+ 690	+ 630
35/65-33 (30PR) L-4 Goodyear	kg	+ 785	+ 545	+ 495
35/65-33 (30PR) L-5 Firestone	kg	+ 1 480	+ 1 030	+ 940
35/65-33 (30PR) L-5 Goodyear	kg	+ 1 470	+ 1 025	+ 930
35/65 R33 RL-5K* L-5 Goodyear	kg	+ 1 180	+ 820	+ 745
35/65 R 33* XLD D2 L-5 Michelin	kg	+ 640	+ 370	+ 330
35/65 R33* XMINE D2 L-5 Michelin	kg	+ 1 230	+ 770	+ 700

SUPPLEMENTAL OPERATING DIMENSIONS		Change in height dimensions	Change in width
Optional tires: 35/65-33 (30PR) L-4 Firestone/ 35/65-33 (36PR) L-4 Firestone	mm	+ 40	- 17
35/65-33 (30PR) L-4 Goodyear	mm	+ 10	- 7
35/65-33 (30PR) L-5 Firestone	mm	+ 40	- 25
35/65-33 (30PR) L-5 Goodyear	mm	+ 10	- 13
35/65R33 RL-5K* L-5 Goodyear	mm	+ 20	- 9
35/65 R 33* XLD D2 L-5 Michelin	mm	+ 15	
35/65 R33* XMINE D2 L-5 Michelin	mm	+ 33	

SUPPLEMENTAL SHIPPING DIMENSIONS		Height dimensions without ROPS canopy	Height dimensions
Lower center hinge – top of cab	mm	3 560	
Rear frame – top of cab	mm	3 550	
Bottom of planetary – top of cab	mm	3 530	
Bottom of differential – top of cab	mm	3 500	
Bottom of wooden wheels – top of cab	mm	3 730	
Bottom of wooden wheels – planetary	mm		200
Bottom of wooden wheels – differential	mm		235

## STANDARD EQUIPMENT

### Service and maintenance

Engine oil remote drain and fill  
Lubrication manifolds, ground accessible  
Radiator remote drain and fill  
Transmission remote drain and fill  
Pressure test ports: transmission and hydraulic, quick connect, grouped on console for easy access  
Fan, hydraulic driven, swing out  
Grille, rear, swing out

### Engine

Air cleaner, dry type, dual element, with exhaust aspirated precleaner  
Coolant filter  
Coolant level sight gauge  
Engine intake manifold pre-heater  
Exhaust rain protection  
Flat-round radiator  
Low emission

### Electrical System

24 volt – prewired for optional equipment  
Alternator, 24 Volt, 80 Amp  
Back-up alarm, acoustic  
Battery disconnect switch, lockable  
Gauges:  
• engine temperature  
• fuel level  
• transmission temperature  
Hourmeter  
Horn, electric  
Lights:  
• instrument lighting  
• parking lights  
• stop/tail combination (2 rear)  
• turn signals with hazard warning switch  
• working lights, 60 watt  
• halogen (6 front and 2 rear)

### Contronic Monitoring System, ECU

Engine shut down to idle  
Brake test  
Neutral start feature  
Test function for warning & monitoring lights  
Information panel (Contronic): start configuration, setting language and units, operating hours, general operating information, stop wath/trip meter, cycle counter, service intervals  
engine  
electrical system  
transmission  
axlea/brakes  
Central Warning (light with buzzer): engine oil pressure, engine coolant temperature (buzzer), transmission oil pressure, transmission oil temperature, brake system pressure, parking brake applied and transmission in forward or reverse (buzzer), front axle oil temperature (buzzer), hydraulic oil temperature, high speed/gear (buzzer) transmission oil filter, fan circuit  
Warning and Monitoring Lights:  
• engine oil pressure  
• engine coolant temperature  
• air cleaner restriction  
• alternator malfunction  
• working lights  
• preheating coil  
• direction indicator  
• hazard warning flasher  
• transmission oil pressure  
• transmission oil temperature  
• brake system pressure  
• parking brake applied  
• front axle oil temperature  
Neutral start feature  
Test function for monitor and warning lights during start-up

### Drivetrain

Countershaft transmission with directional and range modulation  
Single lever control  
Automatic Power Shift (APS II)  
Operator controlled declutch  
Kickdown to 1st switch on shift lever and hydraulic console  
Brakes, full hydraulic, wet disc, continuous oil-cooled, 4 wheel dual-circuit, axle by axle  
Secondary brake system, accumulator supplied  
Differentials: Posi-Torq limited-slip front and rear

### Tyres and rims

35/65-33

### Cab and ROPS Canopy

ROPS Canopy (ROPS, SAE J1040, ISO 3471) FOPS, SAE J231, ISO 3449)  
Cab (ROPS, SAE J1040, ISO 3471)  
Acoustical lining  
Air conditioner, 7kW, 24,000 Btu/h  
Ashtray  
Cigarette lighter  
Door lockable (left side access)  
Door-open struts  
Heater/defroster/pressurizer 11 kW (37,500 Btu/h) with four speed blower fan  
Filtered air for cab  
Floor mat  
Instrument panel with symbols  
Interior light  
Mirror, rearview interior  
Mirror, rearview, exterior (2)  
Operator seat, ISRI, air suspended, heated  
Safety glass, tinted  
Seat belt (SAE J386) retractable  
Steering wheel, telescoping, adjustable tilt  
Windshield washers front/rear

Storage compartment

Sun visor  
Windshield wiper, front and rear  
Window openable, right-hand side  
Wiper, intermittent, front  
Cab access steps, hand rails, service platforms with anti-skid surfaces (SAE J185)

### Hydraulic System

Main, load-sensing valves, 2 spool, pilot-operated  
Pilot valve, 3 spool  
Four variable-flow axial piston pumps (2 have steering priority)  
Boom and bucket control levers, fingertip  
Boom lever detents  
Boom lowering system  
Boom kickout, automatic, adjustable  
Bucket lever detents  
Bucket leveler, automatic, adjustable  
Control lever safety latch  
Steer, load-sensing valve Orbitrol, hydrostatic  
Hydraulic pressure test ports, quick connect  
Hydraulic fluid level sight gauge  
Hydraulic oil cooler

### External

Drawbar with pin  
Isolation mounts: cab, engine, transmission, radiator  
Lifting lugs  
Side panels, engine hood  
Steering frame lock  
Tie-down locations  
Vandalism lock, provision for, batteries, engine coolant, fuel, hydraulic fluid, transmission/torque converter fluid, engine side panels  
Boom to buckets pins with dual double-tapered roller bearings  
Fenders, front  
Mudflap

## OPTIONAL EQUIPMENT *(May be standard in certain markets)*

### Service and maintenance

Tool kit  
Tool box, lockable  
Automatic lubrication system

### Engine equipment

Engine block heater, 120 V (US)  
Engine block heater, 240 V 2500W (US)  
Engine block heater, 220 V 1500W (Europ)  
Universal

### Electrical system

Rotating beacon  
Working lights rear, extra  
Battery for extrem cold weather

### Drivetrain

Switch, forward/reverse at hydr. controls

### Tyres and rims

35/65-33 (30 PR) L4 FS  
35/65-33 (36 PR) L4 FS  
35/65-33 (42 PR) L4 FS  
35/65-33 (30 PR) L5 FS  
35/65-33 (30 PR) L4 GY  
35/65-33 (30 PR) L5 GY  
35/65R33 RL-5K\* L5 GY  
35/65R33 XLD D1\* L4 MI  
35/65-33 XLD D2\* L5 MI  
35/65R33 XMINE D2\* L5 MI

Wood protected rims  
Heavy duty rims

### Cab

Armrest (left) for ISRI operator seat  
Dual brake pedals  
Instructor's seat  
Radio installation kit  
Seat belt 3in

Sliding window, door  
Sliding window right side  
Sound reduction kit  
Throttle, lockable  
Single key door/start

### Hydraulic system

Attachment locking, without bracket  
Biodegradable hydraulic fluid  
Boom Suspension System  
Hydraulic function, 3rd  
Hydraulic function, 4rd

### External equipment

Counterweight 1 - 2 x 520 kg required with long boom  
Counterweight 2 - 2 x 520 kg  
Rear fender, swing-out

### Protective equipment

Guards for stop/tail lights  
Guards for std. working light rear  
Guards for headlights front  
Windshield guard  
Window guards side and rear window  
Protection plates under cab  
Belly guard front  
Belly guard rear  
Hose protection for boom cyl.hoses

### Other equipment

Comfort Drive Control, CDC  
Long boom  
Secondary steering  
Fuel fill strainer

*Under our policy of continuous product improvement, we reserve the right to change specifications and design without prior notice. The illustrations do not necessarily show the standard version of the machine.*

# VOLVO

Volvo Construction Equipment Group

Ref. No. 21 3 669 2268 English  
Printed in Sweden 1999-05, 2,0 WLO  
Volvo Eskilstuna