

Euclid R60C



**MAXIMUM GMW
101 605 KG**

**HAULER CLASS
60,1 TONNE**

**HIGH PERFORMANCE
LOW EMISSIONS ENGINE
RATED GROSS OUTPUT:
522 kW (700 bhp)**

COMMAND CAB III

ALL-HYDRAULIC BRAKING

SWING-OUT GRILLE

**CONTRONIC II
MONITORING SYSTEM**

**AUTOMATIC
TRANSMISSION
TRIM BOOST SOFT SHIFT
TWO-SPEED REVERSE**

**ACCU-TRAC SUSPENSION
NEOCON STRUTS**

LOW LOADING HEIGHT

WET DISC BRAKES

EUCLID



ENGINE

Make	Standard Cummins			
Model	QSK19-C700			
Type	4 Cycle			
Aspiration	Turbocharged/ Aftercooled			
Rated Output (SAE @ 2100 rpm)	kW	bhp	522	700
Flywheel Output (SAE @ 2100 rpm)	kW	bhp	479	643
No. Cylinders	6			
Bore & Stroke	mm	159 x 159		
	in	6 1/4 x 6 1/4		
Displacement	liters	in ³	18,8	1,150
Max. Torque	@ 1300 rpm			
	N•m	lb ft	3 084	2,275
Torque Rise Starting	26% Electric			



TRANSMISSION

Allison M6600, remote-mounted, planetary type, with integral torque converter featuring automatic lockup in all ranges for improved fuel economy. Allison Commercial Electronic Control provides park brake interlock and hoist interlock as well as built in diagnostics. Trim Boost Soft Shift provides smooth shifting to help reduce operator fatigue. Six fully automatic forward speeds and two selectable reverse speeds to supply the operator with more flexibility in any application. Air to oil transmission cooler eliminates potential transmission contamination.

Maximum Speeds Governed Engine Speed with standard 24.00R35(**) E2/E3 tires

Range	Gear Ratio	Standard 3.73:1 Differential		Optional 3.15:1 Differential	
		km/h	mph	km/h	mph
1	4.00	9,9	6.1	12,6	7.8
2	2.68	14,7	9.2	18,8	11.7
3	2.01	19,7	12.2	25,0	15.6
4	1.35	29,3	18.2	37,3	23.2
5	1.00	39,5	24.6	50,3	31.3
6	0.67	59,7	37.1	76,0	47.2
R1	5.12	7,8	4.9	9,9	6.2
R2	3.46	11,6	7.2	14,7	9.1



DRIVE AXLE

Full floating axle shafts, double reduction provided by Euclid Model 2354 differential and single reduction planetary with balanced life gears in each wheel, to maximize gear life.

Ratios	Standard	Optional
Differential	3.73:1	3.15:1
Planetary	5.80:1	5.80:1
Total Reduction	21.63:1	18.27:1

Maximum Speeds with 24.00R35(**)E2/E3 Tires	km/h	mph	km/h	mph
	59,7	37.1	76,0	47.2



TIRES

Standard - Front and Rear	Rim Width
24.00R35(**)E2/E3 Radial	mm in 432 17
Optional tires, brands and treads available.	



ELECTRICAL SYSTEM

Twenty-four volt lighting and accessories system. 75 amp alternator with integral transistorized voltage regulator. Two 900 amps, cold cranking, 12-volt, maintenance-free, heavy-duty batteries connected in series.

Standard CONTRONIC II monitoring and central warning system with built-in diagnostics. Standard Liquid Crystal Display.



LOAD CAPACITY

	m ³	yd ³
Struck (SAE)	28,0	36.6
Heap 3:1	35,8	46.8
Heap 2:1 (SAE)	40,3	52.7

	Tonne	Ton
*Payload depending on optional equipment	60,1	66

Note: Based on material density, Euclid will size an optional larger or smaller body to assure rated payload. Consult Euclid Market Support.



WEIGHTS

	kg	lb
Chassis & Hoist	28 806	63,507
Body	12 667	27,926
Net Machine Weight	41 473	91,433

Maximum Payload	60 132	132,567
Maximum GMW with Std. Tires [24.00R35(**)E2/E3] Including Options, 50% Fuel, Operator & Payload Not to Exceed	101 605	224,000

*Major Options

Approximate change in Net Machine Weight:

Light Duty Body Liners - 400 BHN Steel	2 948	6,500
Heavy Duty Body Liners - 400 BHN Steel	3 719	8,200

Weight Distribution	FRONT	REAR
Empty	48%	52%
Loaded	33%	67%



STEERING SYSTEM

Closed-center, full-time hydrostatic power steering system using two double-acting cylinders, pressure limit w/unload piston pump and brake actuation/steering system reservoir. Accumulator provides supplementary steering in accordance with SAE J1511, ISO 5010. Tilt/telescopic steering wheel with 35° of tilt and 57,15 mm 2 1/4" telescopic travel.

Steering Angle	39°		
Turning Circle (SAE)	m	ft in	19,28 63'3"
Steering Pump Output (@ 2100 rpm)	l/m	gpm	95,7 25.3
System Pressure	kPa	psi	18 961 2,750



HYDRAULIC SYSTEM

Two (2) Euclid two-stage cylinders, double-acting in second stage, internal cushion (extend and retract), inverted and outboard mounted. Separate Hoist/Brake Cooling reservoir and independent tandem gear pump. Equipped with body up speed restriction.

Body Raise Time	s		10.0	
Body Float Down Time	s		14.0	
Body Power Down Time	s		11.0	
Brake Cooling Pump Output	l/m	gpm	176	47
Hoist Pump Output	l/m	gpm	468	123
System Relief Pressure	kPa	psi	17 237	2,500



BRAKE SYSTEM

Brake system complies with SAE J1473 and ISO 3450.

All-hydraulic actuated braking system providing precise braking control and quick system response. The brake controller has a unique variable front to rear brake proportioning that maximizes the stopping performance under slippery road conditions without having to deactivate front brakes.

Service

All-hydraulic actuated front disc brakes and rear oil-cooled wet disc brakes.

Front Axle - Dry Disc

Disc Diameter Each (2 discs/axle)	mm	in	686	27
Brake Surface Area	cm ²	in²	4 129	640
Lining Area Per Axle	cm ²	in²	2 787	432
Brake Pressure (Max.)	kPa	psi	15 859	2,300

Rear Axle - Oil-Cooled Wet Disc

Brake Surface Area Per Axle	cm ²	in²	59 616	9,240
Brake Pressure (Max.)	kPa	psi	4 482	700

Secondary

Two independent circuits within the service brake system provide back-up stopping capability. System is manually or automatically applied to stop machine within prescribed braking distance.

Parking

Expanding shoe type mounted on transmission output shaft. Controlled by a toggle switch on the dash. Automatically applied if brake hydraulic pressure is lost.

Size	mm	in	305 x 127	12" x 5"
-------------	----	-----------	-----------	-----------------

Retarder

Foot-operated valve controls all-hydraulic actuation of oil-cooled wet disc brakes on rear axle. System provides modulated pressure to rear brakes for constant speed control.

Capacity

Continuous	kW	hp	597	800
Intermittent	kW	hp	1 208	1,620



WET DISC BRAKE

The Euclid-designed wet disc brake is engineered for long service life even in the most extreme environments. The wet disc brakes are located on the rear axle and provide service braking, secondary braking, and retarding.

The brakes are a multi-plate design, and continuously oil-cooled. The sealed design protects against environmental contamination for prolonged service life. The wet disc brake is designed with automatic retraction to prevent drag. Separate pedals activate the service braking and retarding functions.

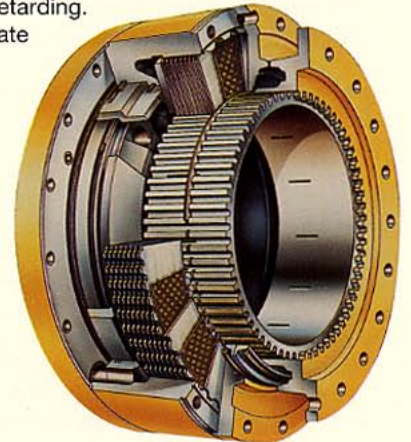

COMMAND CAB III

Command Cab III integral ROPS/FOPS (Rollover Protection Structure) is standard in accordance with SAE J1040 (1994) and ISO 3471. Dimensions comply with SAE J154 (1992) and ISO 3411. Double wall construction of 11 gauge inner and outer steel panels,



lends itself to a more structurally sound cab. Foam rubber lining material along with foam rubber-backed carpeting and multiple layered floor mat act to absorb sound and control interior temperature. A properly maintained cab from Euclid, tested with doors and windows closed per work cycle procedures in SAE J1166 (1990), results in an operator sound exposure L_{eq} (Equivalent Sound Level) of 79db(a). A three-point rubber iso-mount arrangement to the deck surface minimizes vibration to the operator compartment.

Excellent Serviceability. A removable front closure allows easy access to service brake valves, retarder valve and heater assembly. The upper dash utilizes four (4) removable panels that house gauges and customer options, each individually accessible. A removable closure located behind the seat provides easy access to the shifting control, CONTRONIC II, and all electrical junction points.

Comfort and Ease of Operation. A wrap-around style dashboard positions controls within easy reach and visual contact. A full complement of easy-to-read gauges, CONTRONIC II monitoring and warning system with Liquid Crystal Display (LCD), a spacious environment, six-way adjustable mechanical seat, tilt/ telescopic steering wheel, filtered ventilation, door locks, and a padded trainer seat, all contribute to operator convenience and comfort.

STANDARD EQUIPMENT

General

ACCU-TRAC suspension system	Hoist interlock
Air to oil transmission cooler	Hoist tank sight gauge
Allison M6600 transmission	LED taillights
All hydraulic braking	Load/dump brake
Automatic transmission shifting	Mirrors right and left, hand adjustable
Body down indicator, mechanical	Mud flaps
Body up and down cushioning	NEOCON suspension struts
Body up speed restriction w/light	Park brake interlock
Body prop cable	Radiator grill guard
Bolt-on nose cone bushing	Radiator, premium core
Canopy spill guard	Reverse alarm
Continuous heated body	Rock ejector bars
Cooling system sight gauge	Steering accumulator
Cooling system surge tank	Steering tank sight gauge
Electric horns	Swing-out grille
Electric start	Tires, 24.00R35(**)E2/E3
Fan guard	Tire guards, bolt-on
Fenders	Tow points, front/rear
Fixed steering stops	Transmission sight gauge
Guard rails	Two-speed reverse
Halogen lights	

Cab

Acoustical lining	Load counter
Air filtration/replaceable element	Service intervals, job site adjustable
Ash tray	Throttle position
Cab interior light	Total engine hours
Cigar lighter	Total idle hours
Door locks	Voltmeter
Heater and defroster 26,000 Btu	Mechanical, 6 position seat
Integral ROPS/FOPS cab	Modular instrumentation
ISO decals	Quick connect test ports
ISO driver envelope	Roll down windows
Liquid Crystal Display* (CONTRONIC II)	Rubber floor mat
Boost pressure	Safety glass
Clutch pressure	Seat belts retractable (operator)
Distance traveled	Sun visor
Engine oil pressure	Tilt/telescopic steering wheel
Fuel gauge	Tinted glass all windows
Fuel pressure	Trainer seat
Gear selection	12-volt accessory connection
Injector timing rail-pressure	Windshield washer
Intake manifold temperature	Windshield wiper, intermittent
Integrated engine diagnostics	
Integrated transmission diagnostics	

Gauges and Indicators

CONTRONIC II monitoring and alarm system, multi-function indicator lights:

Air filter restriction	Brake temperature
Alternator	Converter temperature
Body up	Coolant temperature
Brake oil temperature	Hourmeter
Brake system low pressure	Speedometer
Central warning	Steering/brake pressure
Converter temperature	Tachometer
Coolant level	
Cooling temperature	
Do not shift	
Engine oil pressure	
Engine service	
Engine shut down	
High beam indicator	
Hydraulic filter restriction	
Park brake applied	
Steering filter restriction	
Steering pressure	
Steering temperature	
Transmission oil pressure	
Transmission filter restriction	
Transmission malfunction	
Turn signals/hazard	
Transmission malfunction	

Machine Lights

Back-up lights (2)	Stop & tail (2)
Clearance lights (2)	Turn signals and four-way flashers
Headlights (4)	

OPTIONAL EQUIPMENT

Air conditioning	Engine heater (oil & coolant)
Air suspension seat	Extra reverse alarm
ACTIVE TRACTION CONTROL (ATC) w/ELECTRONIC DOWNHILL SPEED CONTROL (EDSC)	Fast fueling, fuel only
Body, heavy duty	Front brake cut-off switch
Body liners (400 BHN) plates light or heavy duty	HAULTRONIC II LOAD MONITORING SYSTEM
Body sideboard extensions	High intensity headlights
Canopy spill guard extension	Hoodsides
Cold start aid	Kim hotstart pre-heaters
Differential, 3.15:1 ratio	Lube system, automatic
Driveline guard, front	Lube system, centralized
Driveline guard, rear	Muffler, deck mounted
Electronic hoist	Radio & tape player
Engine belt protection	Sound suppression package
Engine compartment lights	Starter lock-out switch
Engine compartment steps	Tires (size, type & rating)
	Transmission guard
	Transmission retarder

Standard and optional equipment may vary from country to country. Special options provided on request. Consult Euclid Market Support.

* English, French, German, Spanish and Swedish Language selectable.

Note: Dimensions shown are for empty machine with 24.00R35(**)E2/E3

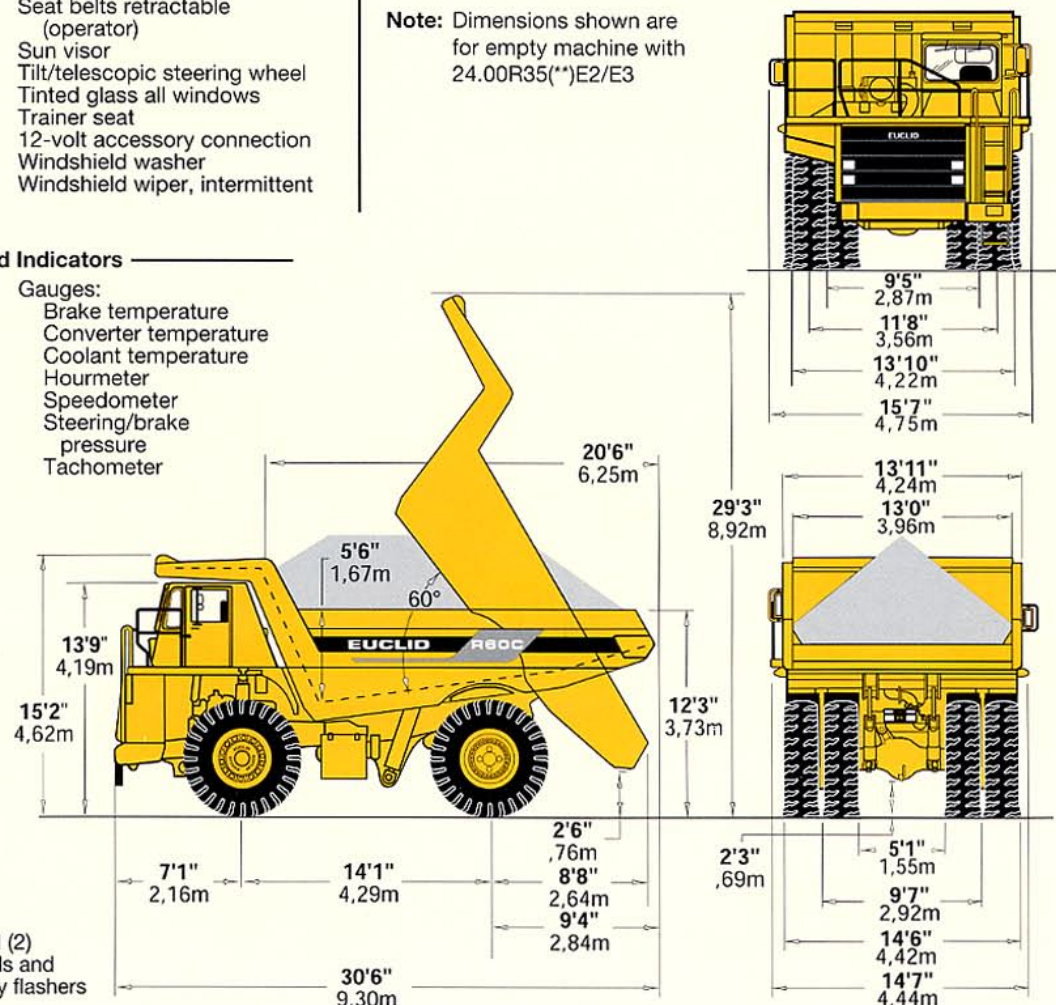



SUSPENSION

Front and Rear Suspension

For years, Euclid haulers have enjoyed an industry-wide reputation for superior suspension systems. That experience and knowledge has now been pushed to the next level, to develop the truly advanced ACCU-TRAC suspension for the R60C. To make sure it was fine tuned to the limit, Lotus Engineering, a world-leader in suspension design, was contracted to review the entire system to assure optimized ride and handling performance.

The new ACCU-TRAC suspension system features independent trailing arms for each front wheel with NEOCON struts, containing energy absorbing gas and compressible NEOCON-E™ fluid, mounted between the king pins and the frame. This arrangement allows a wider front track that provides a better ride, improved stability and a reduced turning circle. The rear axle housing has an A-frame mounting. The rear NEOCON struts are mounted in a more vertical position which allows a more pure axial loading and reduces the tractive and braking forces transmitted to the nose cone.

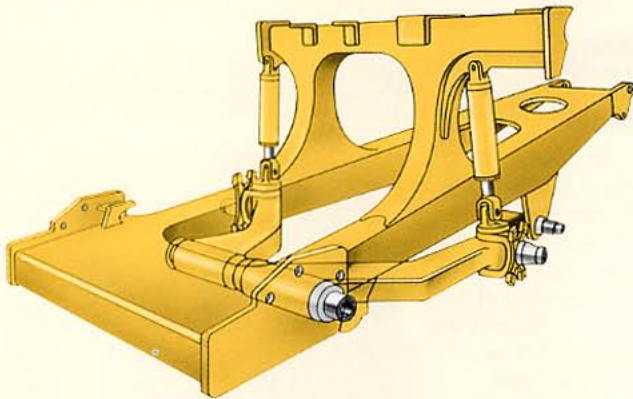

NEOCON struts outperform competitive strut designs by improving isolation, stability, and control. Improved isolation means reduced impact loading on the structural members of the machine and greater operator comfort, resulting in longer equipment life and increased productivity. Improved stability means more consistent dynamic response of the machine to fluctuating load energy, resulting in predictable machine performance. And improved control means better machine maneuverability.

The Euclid frame and ACCU-TRAC suspension system are designed to work in unison to provide maximum structural integrity and operator comfort. The fabricated rectangular frame rail construction provides superior resistance to bending and torsional loads while eliminating unnecessary weight. The unique ACCU-TRAC independent trailing arm suspension absorbs haul road input, minimizing suspension-induced frame twisting while providing independent tire action. NEOCON ride struts are mounted with spherical bushings, eliminating extreme sidewall forces by ensuring a purely axial input to the ride strut. The wide track stance of the ACCU-TRAC suspension system and the long wheel base assure a more stable, comfortable ride.



BODY

Flat chute type, sloped floor, continuously exhaust-heated. High tensile strength 400 BHN abrasion-resistant alloy steel is used in thickness of:

	mm	in
Floor	20	3/4"
Front	12	1/2"
Sides	10	3/8"
Canopy	6	1/4"
Optional Body Liners (Light Duty)		
Floor & Top Rails	10	3/8"
Sides & Front	6	1/4"
Optional Body Liners (Heavy Duty)		
Floor	13	1/2"
Sides & Front	8	5/16"
Top Rails	10	3/8"

The horizontal stiffener design of the Euclid body minimizes stress concentrations in any one area. Load shocks are dissipated over the entire body length. The closely spaced floor stiffeners provide additional protection by minimizing distance between unsupported areas.

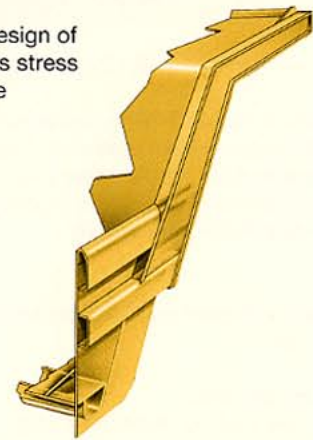

SERVICE CAPACITIES

	liters	gallons
Crankcase (incl. filters)		
Cummins QSK19-C700	60,6	16.0
Transmission (incl. filters)	87,0	23.0
Cooling System		
Cummins QSK19-C700	189,3	50.0
Fuel Tank	700,2	185.0
Hydraulic		
Hoist Tank	174,1	46.0
Steering Tank	98,4	26.0
Drive Axle	118,8	31.4
Windshield Washers	5,7	1.5



FRAME

Full fabricated box section main rails with section height tapered from rear to front. Wider at the rear to support the loads and narrower at the front to allow for engine accessibility. One piece top and bottom flanges that eliminate cross member tie in joints and provide a large exposed center area for access to major components. Large radii at frame junctions are blended and ground to minimize stress concentrations. Weld joints are oriented longitudinally to the principal flow of stress for greater durability and more strength. Frame utilizes 345 MPa 50,000 psi yield strength alloy steel that is robotically welded to ensure high quality welds.

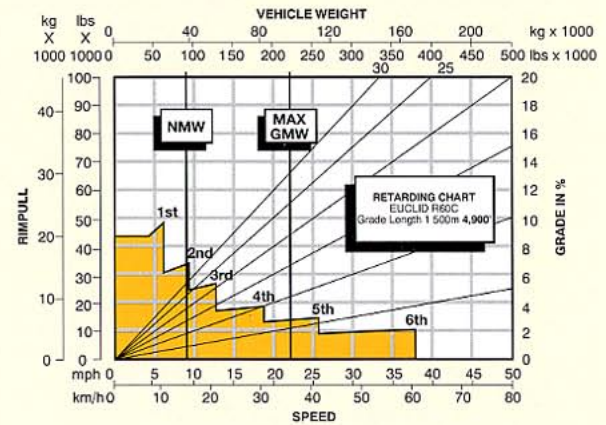
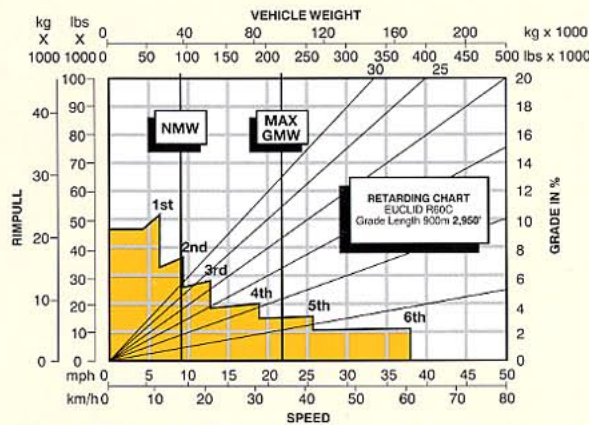
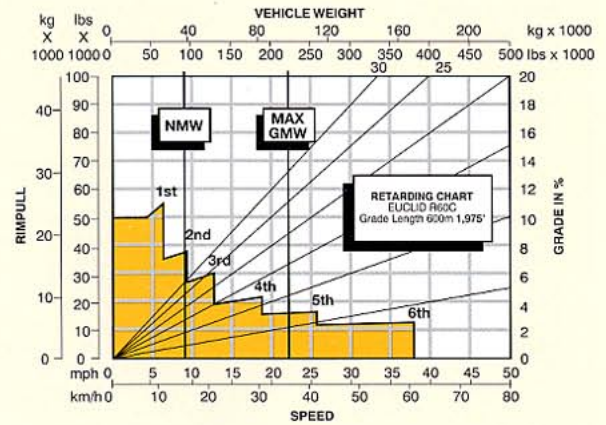
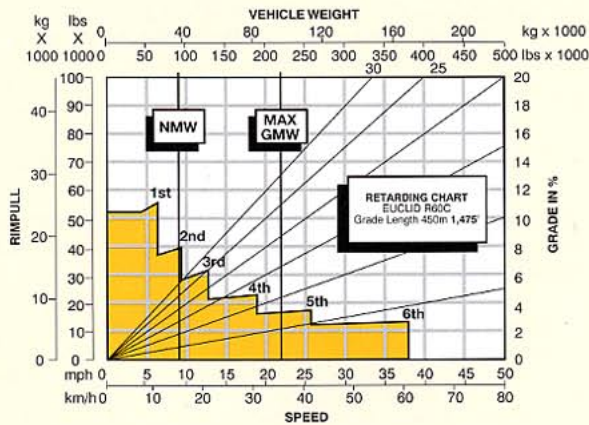
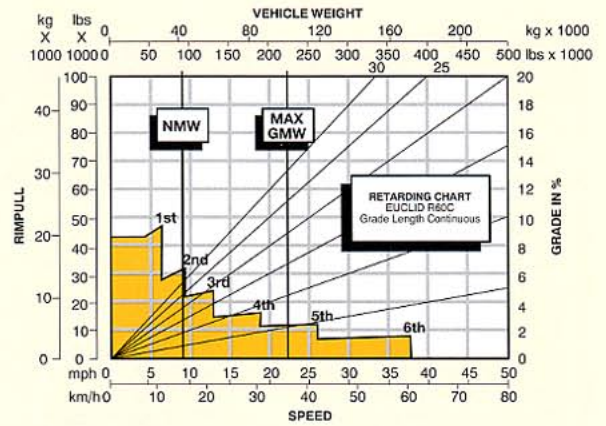
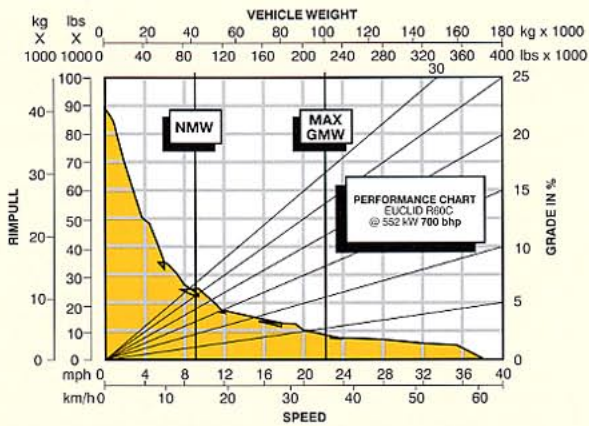

INSTRUCTIONS:

Diagonal lines represent total resistance (Grade % plus rolling resistance %). Charts based on 0% rolling resistance, standard tires and gearing unless otherwise stated.

1. Find the total resistance on diagonal lines on right-hand border of performance or retarder chart.
2. Follow the diagonal line downward and intersect the NMW or GMW weight line.

NOTE: Photos and illustrations throughout may show optional equipment.

3. From intersection, read horizontally right or left to intersect the performance or retarder curve.
4. Read down for machine speed.

NOTE: Maximum payload, weight and speed may vary with application and optional equipment.

Under our policy of continuous product improvement, we reserve the right to change specifications and design without prior notice. The illustrations do not necessarily show the standard version of the machine.

EUCLID-HITACHI Heavy Equipment, Inc. is a joint venture corporation between Volvo Construction Equipment Corporation and Hitachi Construction Machinery Co., Ltd.

EUCLID-HITACHI Heavy Equipment, Inc.

22221 St. Clair Ave.
Cleveland, OH 44117-2522
www.euclid-hitachi.com



FORM NO. 21 1 431 1559 EU
DATE 3/98
Printed in U.S.A.