

VOLVO COLD MILLING MACHINE

MW500



VOLVO MW500: INNOVATIVE MILLING TECHNOLOGY IN A COMPACT FORMAT

The MW500 is our innovative all-rounder for multiple milling applications in asphalt and concrete. Its back-up safety systems, intelligent controls, and perfect straight line travel thanks to the Line Manager, make it the technological yardstick in the half-metre class. This machine accepts no compromises.

The MW500 permits milling widths of 80 to 500 mm, has a mechanically driven milling drum and is fitted (as a standard feature) with the electronic anti-slip control (ASR). With its patented Line Manager the milling machine travels as if being pulled along a ruler.

Its fields of application include the widening of surfacing strips, partial lane repairs, connection work, free milling around manhole covers or even small slide covers. The cutting wheel permits 80 mm wide cuts for special applications.

Easy operation

The ease of operation is typical of Volvo. The MW500 is the world's first milling machine with an Electronic Planer Management (EPM) system. The EPM control unit can be positioned to meet the optimum ergonomic setting for the operator. The driver can view all the relevant information at a glance on the large backlit LCD screen.

Thanks to the hydraulic steering very tight steering angles can be achieved with ease, e.g. when the driver is milling a small radius around manhole covers.

With its three drive modes "working, manoeuvring, transport", the MW500 offers the optimum presetting for your application. In transport mode as well as in manoeuvring mode the driver can pre-select the travel speed and engine speed with the joystick, infinitely variable from standstill to the maximum speed.

Scaling the speed range: The driver can pre-define the maximum speed in the end position of the joystick. This allows extremely fine adjustments to the travel speed both in the manoeuvring and milling mode.

Service and maintenance work made easy

Service access is a top priority with a technology that, by its very nature, involves high forces and wear.

With well thought-out access to the maintenance points, the time for exchanging the tools or changing the milling drum is considerably reduced.

Engine power and energy efficiency

The MW 500 has a powerful diesel engine which satisfies the strict requirements of the exhaust gas standards of the EPA Tier III and those of the EU, stage IIIA. An automatic rpm control ensures maximum advance even with large milling depths and resistances.

Two belt packages, which are automatically tensioned by a hydraulically adjustable intermediate shaft, are used to transmit power from the engine to the drum gearbox. The uniform loading ensures a long service life.

The independently driven high-performance fan ensures trouble-free working even at high outside temperatures. The fan has a temperature-dependant control system. As a result, Volvo reduces fuel consumption and the noise level.



The strengths of the MW500 at a glance:

- small milling machine with the technology of a big one
- low centre of gravity, very stable road holding
- extremely tight milling radius of 200 mm – previously unattainable by 4-wheel milling machines
- electronic anti-slip control allowing for superior traction
- Electronic Planer Management EPM: compact control station, offering a wealth of operating data in the coloured display; storage functions of previous settings
- comprehensive safety features
- easy to maintain
- water tank designed for long working cycles and hence increased productivity



GROUNDBREAKING SOLUTIONS FOR YOUR MILLING PROJECTS

Innovative control and monitoring

Unique in this milling class: The MW500 has the innovative EPM "Electronic Planer Management". The milling depth is displayed in the EPM panel both as a numeric value and as a bar chart. The EPM milling depth cut-off facility permits the interim storage and retrieval of milling data. This helps to prevent overcutting and allows for a fast reset.

When the function "automatic" is chosen, the EPM automatically operates all functions necessary to change from the milling to transport mode. This includes the milling drum, sprinkler system, conveyor belt, drive mode, and engine speed.

Patented traction control "Line Manager" as standard

The MW500 is equipped with 4-wheel drive and an anti-slip control. Additionally, the patented Line Manager guarantees that the direction of travel is always accurately controlled. Like all milling machines of this design, the MW500 has an off-centre milling drum which generates drift. The Line Manager compensates for this effect using the electronic all-wheel drive. For the user straight line travel is ensured at all times.

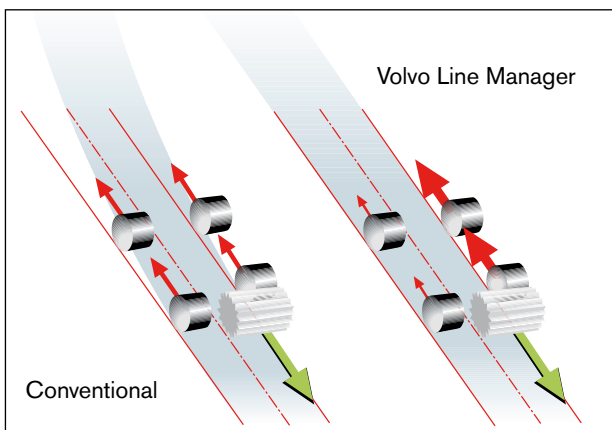

All around the milling drum

The milling drum unit is equipped with hydraulically activated side and front boards. The particularly robust design ensures optimum floating and high wear resistance.

In conjunction with the optional conveyor belt, the milling machine is equipped with a hydraulically movable mold board. When the rear right support wheel is swivelled in or out, the milling machine is deposited on the mold board instead of on the tools. As a result, the tools are not damaged and their service life is extended.

Volvo safety

Safety for the operator is one of Volvo's core values. This thinking is implemented consistently with the new design of the milling machine generation. The operation and maintenance of the milling machine are safer than ever before.

1. Anti-tip technology. When the rear right leg is swivelled inboard, the conveyor has limited swing to the right. This ensures that the centre of gravity is not beyond the edge of the milling drum. When the leg is in its outside position, the conveyor can fully swing in both directions.

2. When the tools are being replaced, the milling drum is automatically deactivated by a contact switch.
3. To start the milling drum, the operator must press two buttons simultaneously. Unintentional activation of the milling drum is therefore prevented.
4. During maintenance work under the milling machine the support wheels are secured with pins to prevent unintentional lowering.
5. The MW500 has an emergency stop on the driver's platform and, in addition, one each on the left and right-hand machine sides which can be activated from the ground.
6. To protect against vandalism, the joystick is simply folded downwards at the end of work and its console locked. The EPM control panel is protected against damage by a steel cover.





Operation by day and by night

The brightly illuminated display and the backlit controls permit working in bright sunlight and in pitch darkness.



Manoeuvrability = Productivity

The rear right-hand support wheel can be hydraulically swivelled and locked to ensure flush milling at curb edges.



Quick connect conveyor belt

The optional conveyor belt can be rapidly mounted and removed.



Changing the milling drum

Changing the milling drum is simple. For this purpose, the Volvo side cutter box is rotated 90° and the entire milling drum pulled out. This work is completed very quickly with the assembly device which Volvo offers as an option.



DIMENSIONS

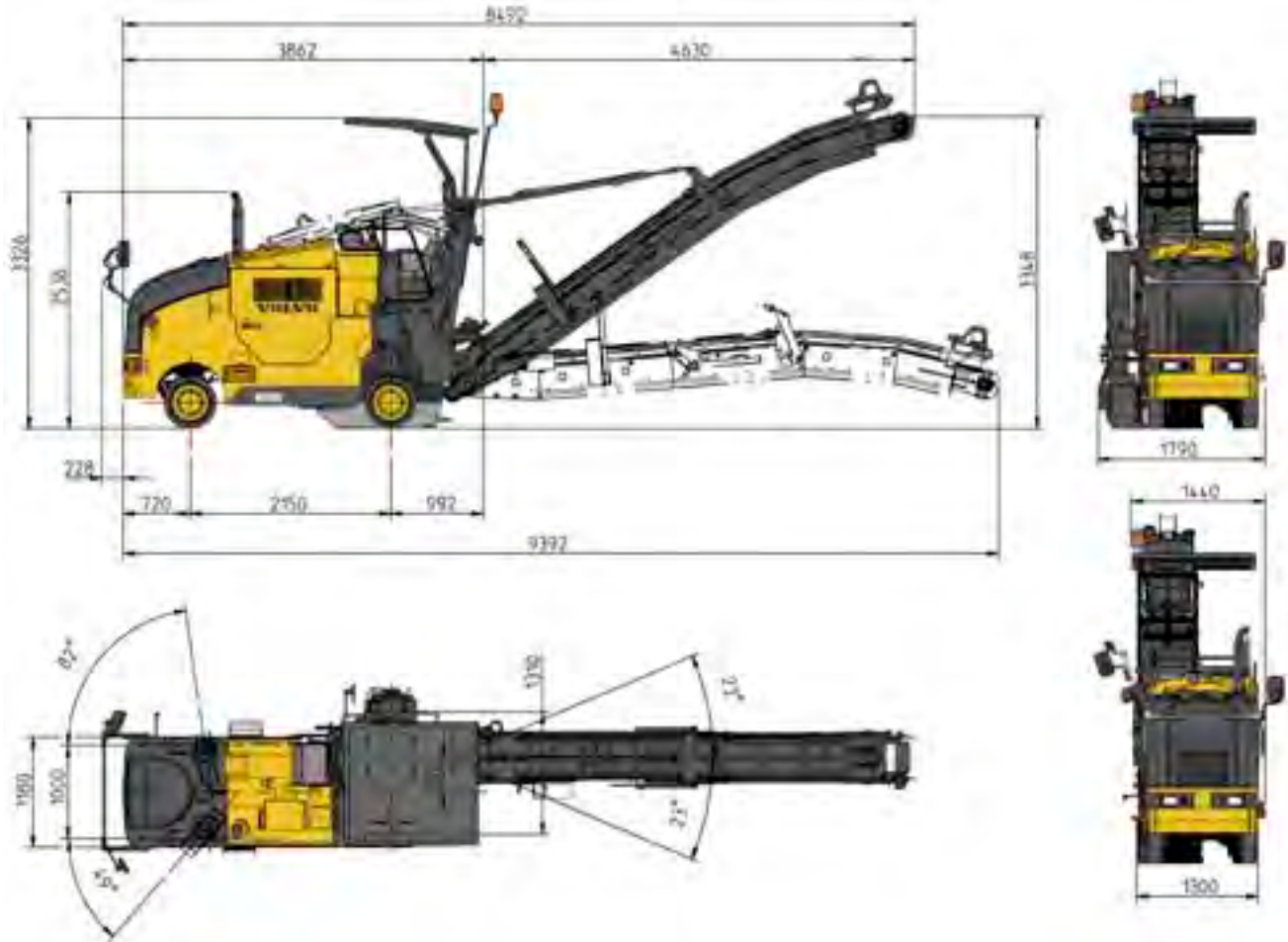

FEATURES

Standard (S) Optional (O)	S	O		S	O
Deutz Diesel engine, COM IIIA/EPA Tier III	•		Vibration-proof operator's platform	•	
4 wheels, front wheel steering	•		All weather roof		•
Electronic Planer Management (EPM)	•		Sprinkler system with interval switch - water saving feature		•
Milling drum 500 mm - standard tool holders (C 10 / 62 + RP18)		•	Adaption for high ambient temperatures up to 55° C		•
Milling drum 500 mm (750/500/15-1/54, with sleeved bit holder system KPF201, full conveyor functions)		•	Milling box with protective cover	•	
Milling drum 400 mm (750/400/15-1/52, with standard bit holder system C10, conveying process hampered)		•	Automatic parking brake	•	
Milling drum 300 mm (750/300/15-1/45, with standard bit holder system C10, conveying process hampered)		•	Electronic controlled all-wheel drive with anti-slip control	•	
Fine Milling drum 500 mm milling width (750/500/8-1/90, with standard bit holder system C10, conveyor functions)		•	Electronic output regulator	•	
Cutting ring (milling width 80 mm, conveying process hampered)		•	Safety package incl. warning beacon, rear view mirrors, back-up alarm, operator presence cut-off switch in seat and platform	•	
Laterally swivelling RH wheel support, electro/hydraulically controlled	•		Special assembly device for easy drum exchange		•
Patented LINE MANAGER (traction power adjustment)	•		Tilting adjustable steering column	•	
Conveyor with hydraulically raised rear moldboard, warning strobe light, work light and horn	•	•	Adjustable operator's seat with seat switch	•	
			Towing device	•	
			Hydraulic side plate lifters and front plate	•	
			EMERGENCY-STOP switch on platform and on the sides	•	
			Biodegradable Oil Panolin		•
			C-Coupling for watertank		•

Partial listing of standard equipment and available options

SPECIFICATIONS

Specifications			
Engine (Diesel)	Model		Deutz TCD 2012 L04 2V
	Output	kW (HP)	95 (129) @ 2 300 min ¹
	Coolant		Liquid
	Exhaust emission		COM IIIA /EPA Tier III
Standard drum	Drum width (max.)	mm	500
	Milling depth (max.) ¹	mm	210
	Tooth spacing	mm	15
	Number of teeth		62
	Drum diameter	mm	750
Working performance	Working speed	m/min	35
	Travel speed	km/h	7,9
	Theoretical gradeability	%	60 (operation) / 10 (max. travel speed)
	Ground clearance	mm	230
Undercarriage	Number of wheels		4 (solid rubber)
	Wheels dimensions front (Ø x W)	mm	560 x 180
	Wheels dimensions rear (Ø x W)	mm	560 x 270
Conveyor	Belt width	mm	350
	Theoretical conveyor capacity	m ³ /h	80
Electrical system		V	24
Transport dimensions	L/W/H		
	- standard version without conveyor	mm	3 925 / 1 790 / 2 540
	- with conveyor	mm	9 400 / 1 790 / 2 540
Tank capacities	Water tank	l	600
	Fuel tank	l	220
	Hydraulic tank	l	68
Weights	Front axle load, full tanks		
	- standard version without conveyor	kg	4 550
	- with conveyor	kg	3 600
	Rear axle load, full tanks		
	- standard version without conveyor	kg	4 050
	- with conveyor	kg	6 000
	Operating weight EN500 ²		
	- standard version without conveyor	kg	8 100
- with conveyor	kg	9 100	
Shipping weight ³			
	- standard version without conveyor	kg	7 600
	- with conveyor	kg	8 600

¹ The maximum milling depth may deviate from the value indicated, due to tolerances and wear.

² Weight of the machine with 1/2 water tank, 1/2 fuel tank, 75 kg operator and tools.

³ Dry weights of the basic machine without any additional equipment.

VOLVO CONSTRUCTION EQUIPMENT

Volvo Construction Equipment is different. Our machines are designed, built and supported in a different way. That difference comes from an engineering heritage of over 180 years. A heritage of thinking first about the people who actually use the machines. About how to help them be safer, more comfortable, more productive. About the environment we all share. The result of that thinking is a growing range of machines and a global support network dedicated to helping you do more. People around the world are proud to use Volvo.

Not all products are available in all markets. Under our policy of continuous improvement, we reserve the right to change specifications and design without prior notice. The illustrations do not necessarily show the standard version of the machine.

VOLVO

Volvo Construction Equipment
www.volvoce.com

Ref. No 20000783-A
2012.07
Volvo, Global Marketing

English-21
MEW