

VOLVO BM 3200

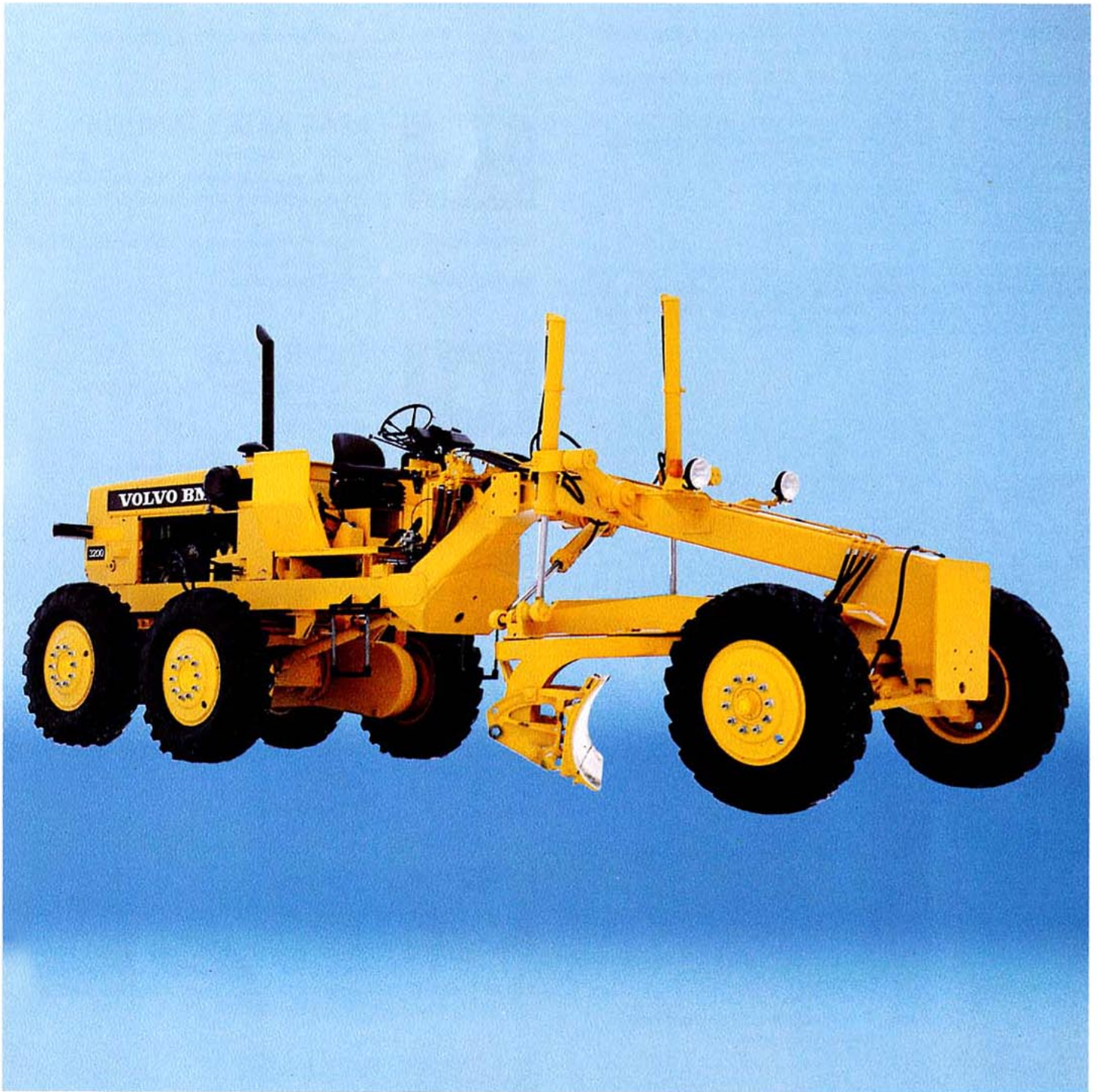

Specification Volvo BM 3200 Motor Grader

TIME-TESTED BASIC DESIGN

The Volvo BM 3200 is a fully hydraulic motor grader with very efficient features. It is an outgrowth of Volvo BM's long-seasoned know-how in the field of motor grader manufacture and experience from jobs under highly diverse conditions.

POWER RESOURCES

The transmission in the 3200 is composed of well-proven Volvo BM components which have been rigorously tested and are well-matched to each other. The engine is a reliable and economical Volvo turbodiesel which can be found in machines all over the world. Its high power and even torque give the 3200 ample power in all situations.

ECONOMICAL

The 3200 is reliable because it is composed of high-quality components in a robust, simple design. The service parts are readily accessible for easy service. The 3200 is also thrifty on fuel consumption, which contributes to good economic yield.



ENGINE

Volvo TD 60 (turbo-diesel)

Flywheel rating	136 hp at 2300 rev/min DIN 70020 Net (100 kW at 38.3 rev/s)
Engine rating	147 hp at 2300 rev/min SAE J 270 Gross (108 kW at 38.3 rev/s)
Max torque	473 hp Nm at 1600 rev/min DIN 70020 Net 492 Nm at 1600 rev/min SAE J 270 Gross
Number of cylinders	6
Cylinder diameter	98.43 mm (3.875 in)
Stroke	120 mm (4.72 in)
Displacement	5.48 litres (334 in ³)
Compression	16:1

Six-cylinder, in-line, direct-injected, turbocharged, four-stroke diesel engine with overhead valves and wet replaceable cylinder linings. Cyclone-type air cleaner and paper filter with high-efficiency filter and pressure drop indicator.



ELECTRICAL SYSTEM

Voltage	24 V
Alternator	1080 W (45 A)
Batteries	4 x 12 V, 120 Ah
Starter motor	6 hp (4.4 kW)



CLUTCH

Type	Double-disc dry plate clutch
Diameter	14"
Operation	Foot-operated via air-assisted pedal



GEARBOX

Type: Fully-synchronized forward gears, single-lever-operated

Number of gears, forward/reverse: 8/2

Gear		Gear	
Forward	Speed km/h (mph)	Reverse	Speed km/h (mph)
1	4 (2.5)	1	4 (2.5)
2	6 (3.7)	2	18 (11.2)
3	8 (5.0)		
4	11 (6.8)		
5	16 (10.0)		
6	22 (13.7)		
7	31 (19.3)		
8	42 (26.1)		



DROP-BOX

Make Volvo BM
Ratio 34/35

The gears in the drop-box have silent-running helical gears. Rubber-mounted in frame.



REAR AXLE & TANDEM

Make Volvo BM

The drive axle is fully floating with differential, equipped with air-operated differential lock.

Tandem housing:	height x width x thickness: 576 x 128 x 20 mm (22.7 x 5.0 x 0.8 in)
Tandem drive:	gear transmission

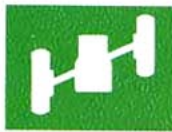

FRONT AXLE

Ground clearance	550 mm (22.2 in)
Oscillation	± 15°
Wheel lean	± 18°

Arched box construction for optimum ground clearance
Turning radius 9.2 m (30.5 ft) outside front tyres



STEERING SYSTEM

Type	Hydrostatic steering
Pump type	Wing pump
Capacity	17 l/min (4.5 US gal/min, 3.7 Imp. gal/min)
Working pressure	90 bar
Steering angle	50° right or left
Steering wheel	Fully adjustable



BRAKES

Air-mechanical drum brakes on front-bogie wheels. Parking brake acts mechanically on front bogie wheels, whereby locking force is applied by coil spring, released pneumatically.



VOLUMES

Engine, including filter	14 litres (3.7 US gal, 3.1 Imp. gal)
Gearbox	8.8 litres (2.3 US gal, 1.9 Imp. gal)
Hydraulic system	140 litres (37.0 US gal, 30.8 Imp. gal)
Hydraulic tank	105 litres (23.9 US gal, 19.8 Imp. gal)
Fuel tank	232 litres (59 US gal, 49 Imp. gal)
Cooling system	30 litres (7.9 US gal, 6.6 Imp. gal)
Rear axle casing – centre gear	25 litres (6.6 US gal, 5.5 Imp. gal)
Bogie boxes, each	15 litres (4.0 US gal, 3.3 Imp. gal)
Drop-box	5 litres (1.3 US gal, 1.1 Imp. gal)
Worm gear, rotation circle	1.5 litres (0.4 US gal, 0.3 Imp. gal)

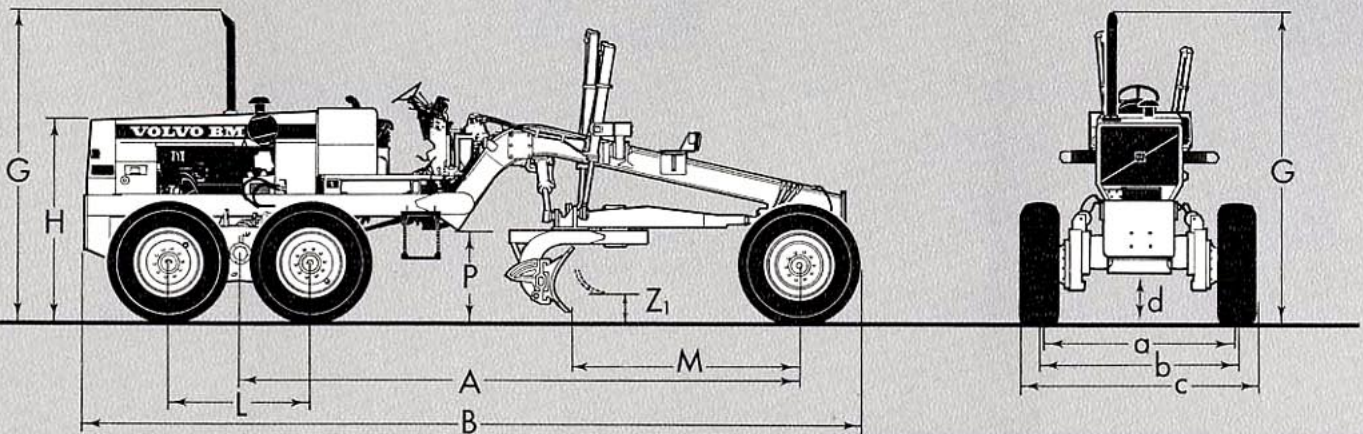

DIMENSIONS

A	5 800 mm (228 in)
B	8 185 mm (322 in)
G	3 320 mm (131 in)
H	2 090 mm (82 in)
I	1 530 mm (60 in)
	2 350 mm (93 in)

P	915 mm (36 in) ground clearance, frame
Z ₁ max.	535 mm (21 in)
a	1 990 mm (78 in) front wheels
b	2 030 mm (80 in) rear wheels
c	2 420 mm (95 in)
d min.	385 mm (15 in)



TYRES

Standard 13.00x24 — 10 PR SGG



ROTATION CIRCLE

Welded box section, diameter 1486 mm (59 in), hardened steering and wear surfaces, 4 adjustable points of attachment to drawbar. Hydraulically driven, with self-inhibiting worm gear. 360° rotation.



HYDRAULIC SYSTEM

mp type
Capacity 2x97.8 l/min (2x25.8 US gal/min, 2x21.5 Imp. gal/min) at 2300 rev/min
Working pressure 140 bar
Dual-circuit system with independent control of functions on left-hand and right-hand sides of machine.



GRADER BLADE

Blade length	12' — 3659 mm
Blade height with cutting edge	640 mm (25 in)
Blade thickness	18 mm (0.7 in)
Cutting edge	HxL: two 152x16x1830 (6"x3/8"x6")
Blade side shift	Air-operated lock
Max. reach beyond wheels in left-hand traffic	2570 mm (101 in) left, 1130 mm (45 in) right



CONTROLS

There are six valves as standard. The controls are tightly grouped and very easy to operate. To make the operator's work even simpler, each lever has a distinctly different knob for easy recognition. Lever movements are logical; if the blade is to be shifted to the right, the lever is moved to the right and vice versa. Another special feature, double command, enables both sides of the blade to be raised and lowered using only the right hand, leaving the left hand free for other functions.



DRAW BAR

A-shaped solid section beam with 4 adjustable guide shoes which fix the rotation circle in the right position. The ball joint is easy to replace.



FRAME

Front sec. Welded box-section construction from front plate to rear frame members.

Top and bottom plates	t = 25 mm (1 in)
Side plates	t = 15 mm (0.6 in)
Section w x h	= 280 x 255 mm (11 x 10 in)
Min. section weight	155 kg/m (104 lb/ft)

Rear sec. Rear frame made of two solid members

W x h	= 50 x 220 mm (2.0 x 8.7 in)
Min. section weight	2 x 87 kg/m (2 x 58 lb/ft)



WEIGHTS

Working weight for standard-equipped machine including oils, coolant, full fuel tank and operator.

Weight on front axle	3 200 kg (7 050 lb)
Weight on rear axle	8 000 kg (17 640 lb)
Total weight	11 200 kg (24 700 lb)
Max. grader cutting pressure	5 400 kg (11 900 lb)



OPERATOR PLATFORM

The operator's seat is fully individually adjustable, including adjustment for the operator's weight. Adjustable steering wheel.

Levers and controls located within the recommended distance for easy reach. Tool compartment located to the left of the operator and can be locked.

STANDARD EQUIPMENT



ENGINE & ELECTRICAL SYSTEM

Instrument panel in front with:	Hour counter
Fuel gauge	Alternator
Ignition switch	Horn
Pilot lights for charging, high beam, direction indicators, engine oil pressure, parking brake, air brakes, differential lock.	Two headlights with high and dipped beam
Hand lamp outlet	Two front blinkers
Thermometer, engine	Two taillights with brake lights, back-up lights and blinkers
Pressure gauge, air brakes	Air outlet for tyre pumping
	Tool kit
	Master switch

OPTIONAL EQUIPMENT

Hydraulic blade sideshift
 Hydraulic blade tip
 Hydraulic V-type scarifier
 End bits
 Hydraulic arrangements with three additional hydraulic valves for hydraulic side shift, blade tip and scarifier
 Canopy
 Tyre inflation kit
 Tyres: 14.00 x 24
 16.00 x 24

VOLVO BM

VOLVO BM AB ESKILSTUNA SWEDEN

The manufacturers reserve the right to change specification or design without prior notice. Illustrations do not necessarily show the machine in its standard version.

Ref. No. 21 1 669 1437
ENGELSKA
 Production group for basic printed matter: Volvo BM
 Photo: Foto Consult