

VOLVO BM 3200 & 3300



The new Volvo BM 3200 & 3300 — two efficient road builders

The Volvo BM 3200 and 3300 are two motor graders with unmatched reach and capacity. Their design reflects Volvo BM's many years of experience in the manufacture of motor graders and the vast knowledge gained on the varied worksites of the world. The result is two truly efficient machines which successfully combine Volvo know-how with tried-and-tested Volvo components.

Frame

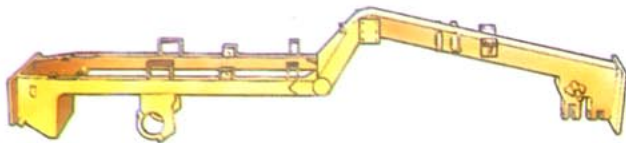

The rugged unit construction frame has exceptional torsional rigidity. The front section is a reinforced box construction, while the rear section — where the engine and transmission are mounted — is made up of solid members.

Safety brakes

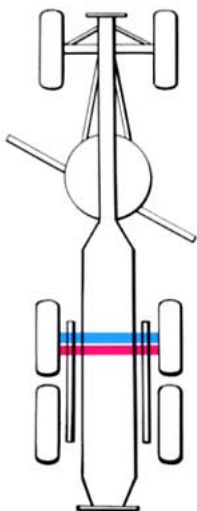

Air operated heavy duty driving brakes on the bogie's front axle. The parking brake has the same safety function as on Volvo Trucks. If the air pressure should drop below the safe working pressure, the brake is applied and locked by spring force, and cannot be released until the correct air pressure has been re-attained.

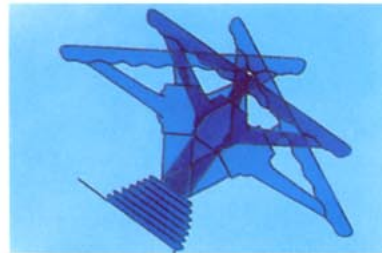

Control levers

Closely grouped controls with double command for the blade's lifting function. Logical level movements with distinctly different knobs enable the driver to work quickly and positively. This machine is equipped with levers for the three optional hydraulic functions. The steering wheel is fully adjustable to different driving positions.

Hydraulic system

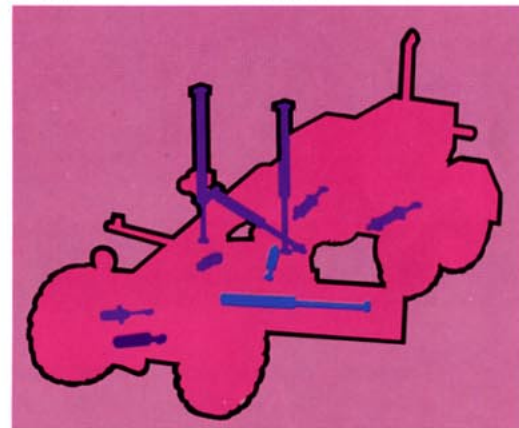

The Volvo BM 3200 has a high-capacity dual-circuit hydraulic system with six functions, including one reserve, as standard. And additional three functions can be added.

Hydraulic pump

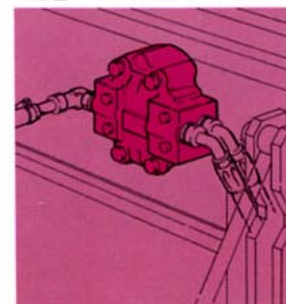

A powerful twin gear pump gives the dual-circuit system plenty of muscle.

Differential lock

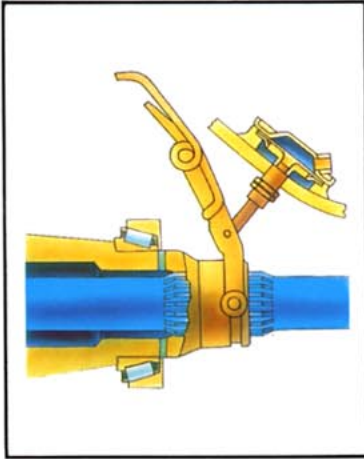

The differential lock is pneumatically operated and provides 100% lockup between the drive wheels. This ensures positive traction on slippery surfaces and when high grading resistance is encountered.

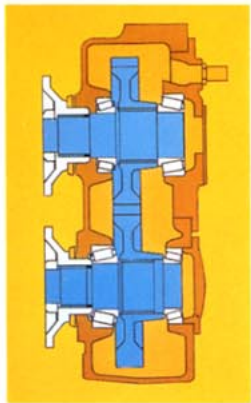

Drop box

The drop box has silent running helical gears for a low noise level.

Volvo turbodiesel

The Volvo TD 60 B turbodiesel is a duty-proven and reliable engine. More than 75,000 TD 60 Bs have been sold. A 6-cylinder engine with direct injection and turbocharging, the TD 60 B provides greater power through more efficient combustion, as well as cleaner exhaust gases and better fuel economy.

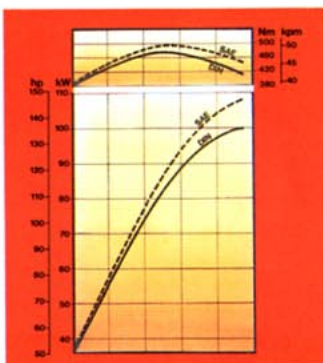

High HP/ Weight ratio

High horsepower/weight ratio and low fuel consumption provide high productivity and good operating economy.

Power pack composed of tried-and-tested Volvo components

The transmission in the Volvo BM 3200 and 3300 is made up of tried-and-tested Volvo BM

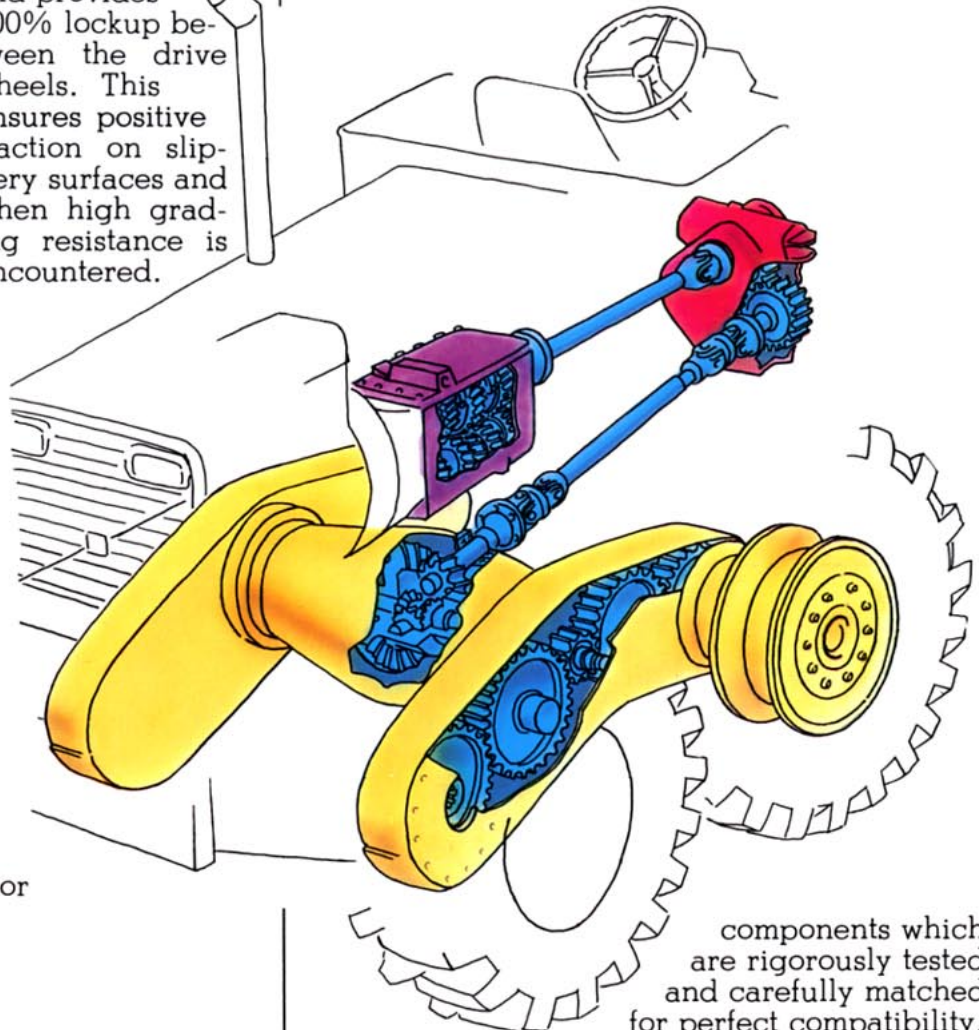

components which are rigorously tested and carefully matched for perfect compatibility.

The result is a highly productive machine that can perform efficiently and profitably for many years. The synchronized 8-speed gearbox enables the engine to be utilized efficiently within a wide range of speeds, offering savings from reduced fuel consumption.

Gearbox

The clutch is hydraulically operated with air-servo and the gearbox has eight fully synchronized forward gears and two reverse. The 3200 and 3300 have a very wide range of speeds and tractive power.

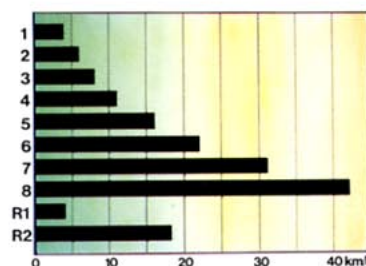

Designed for excellent reach

Due to their advanced design, the 3200 and 3300 are efficient in all situations. They are highly manoeuvrable in tight spaces and have an excellent reach with the 12-foot blade.

Circle

The circle is a welded box-section fabrication with a one-piece gear run. It is carried in four

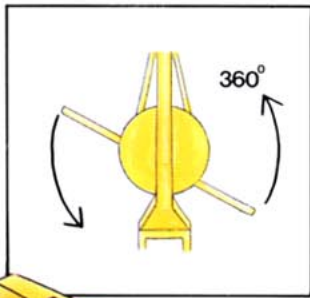

bearings on the drawbar. These bearings can be finely adjusted to achieve a precision mesh. Hydraulically driven worm and gear provide full 360° rotation. This enables the machine to grade even when reversing.

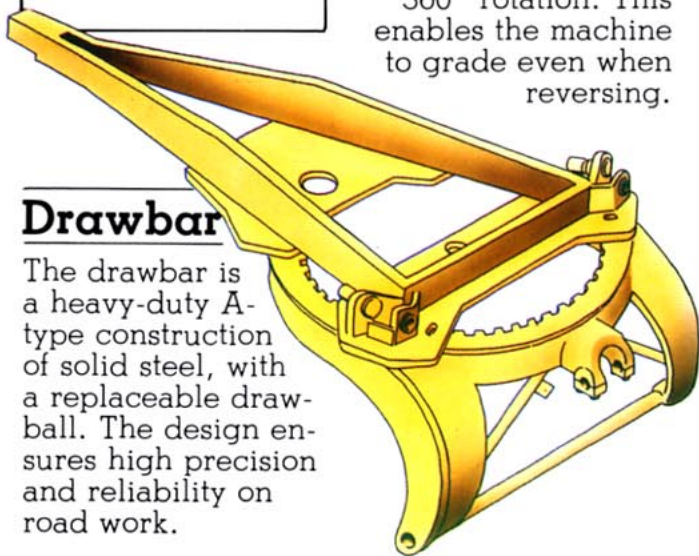

Drawbar

The drawbar is a heavy-duty A-type construction of solid steel, with a replaceable draw-ball. The design ensures high precision and reliability on road work.



Large working range

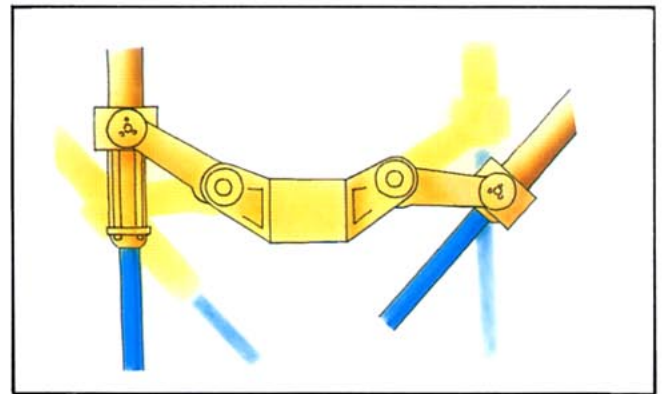

Individual adjustment of the cylinder arms gives the high grader blade a wide range of movement in both directions.

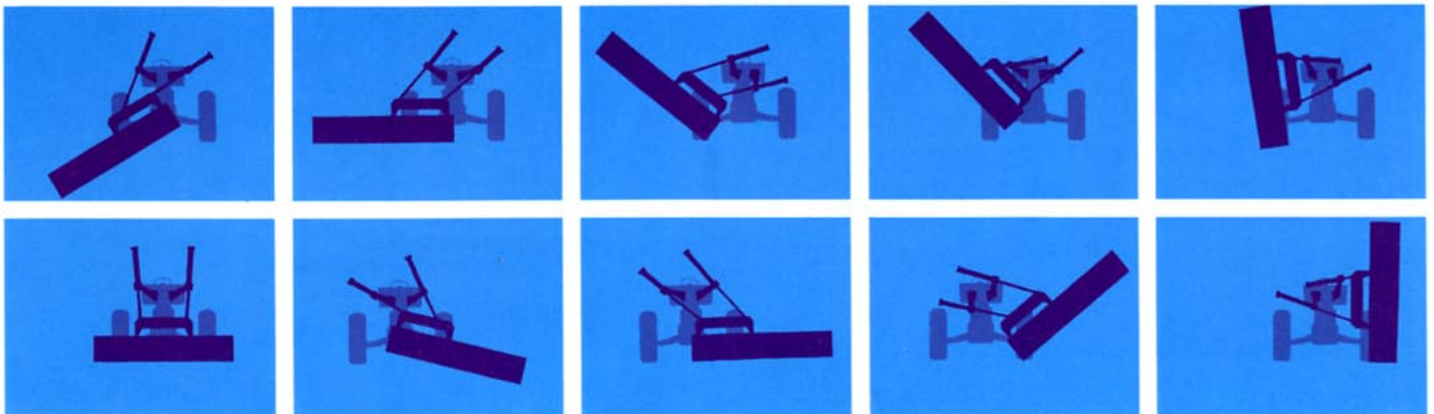

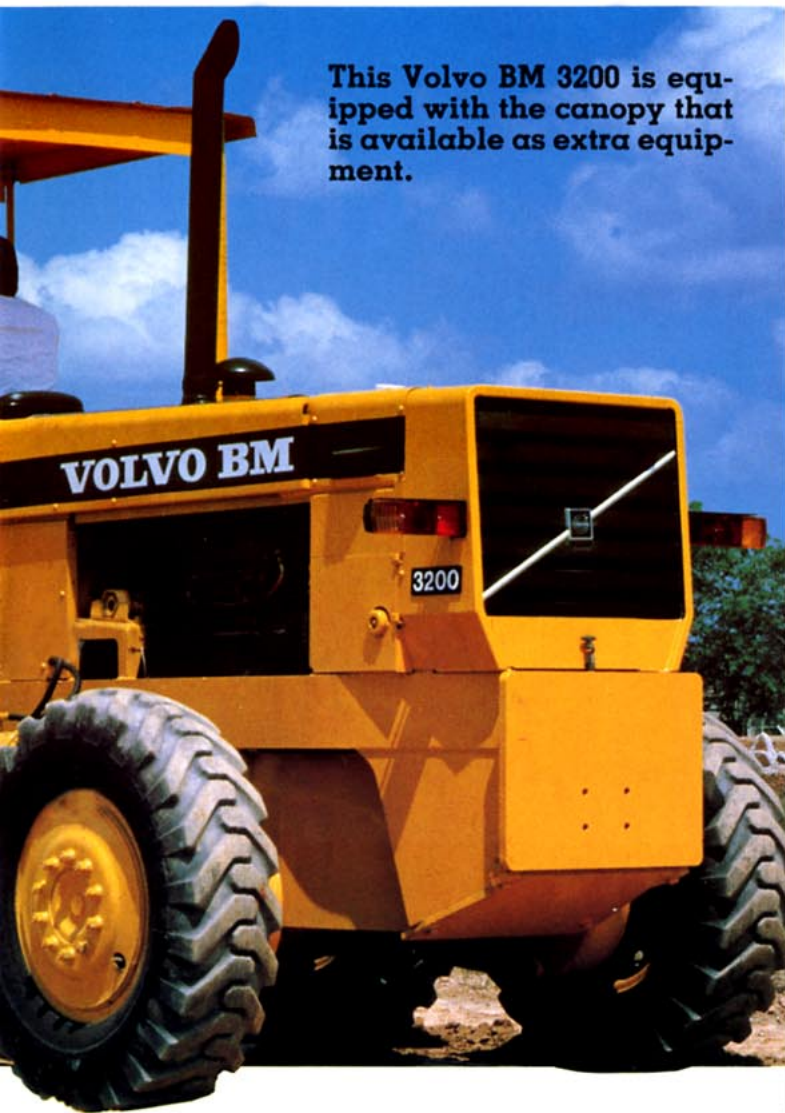

This Volvo BM 3200 is equipped with the canopy that is available as extra equipment.

Precision regulation

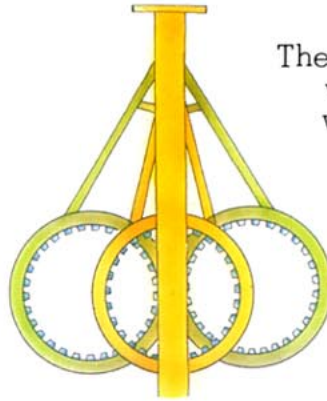

The circle can be regulated with precision through a wide range, by means of a well designed and powerful hydraulic system.

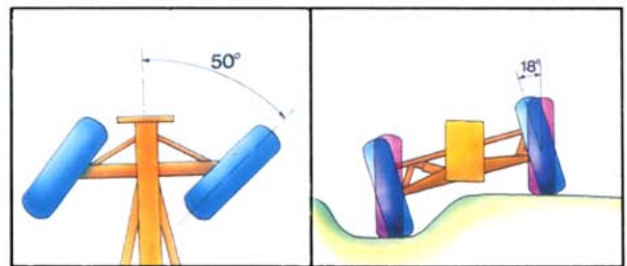

With a turning radius of only 9.2 metres (30 ft) the 3200 is highly manoeuvrable.

Front wheel lean and front axle oscillation both contribute to continuous, good traction, even on deeply rutted surfaces — or when grading with one wheel in a ditch.

Good blade angles

The blade pitch angle can be varied by up to 45°. This comes in handy when you want fine-adjustment of the cutting depth or just need the best cutting angle. Hydraulic bladshift and — tilt are optional as extra equipment.



The rear side of the grader blade is of a completely new design with box welded reinforcement.



Sealed ball sockets



The drawbar journals are carried in sealed spherical bearings, guaranteeing minimum play in the ball sockets and thereby better working results. This also reduces wear and the need for service and spare parts.

The Volvo BM 3300 has articulated bogie steering that boosts performance

The Volvo BM 3300 really makes road work easier. Its design and equipment are the same as on the Volvo BM 3200, except that the 3300 has articulated bogie steering, and nine hydraulic functions as standard, including one for the bogie steering.

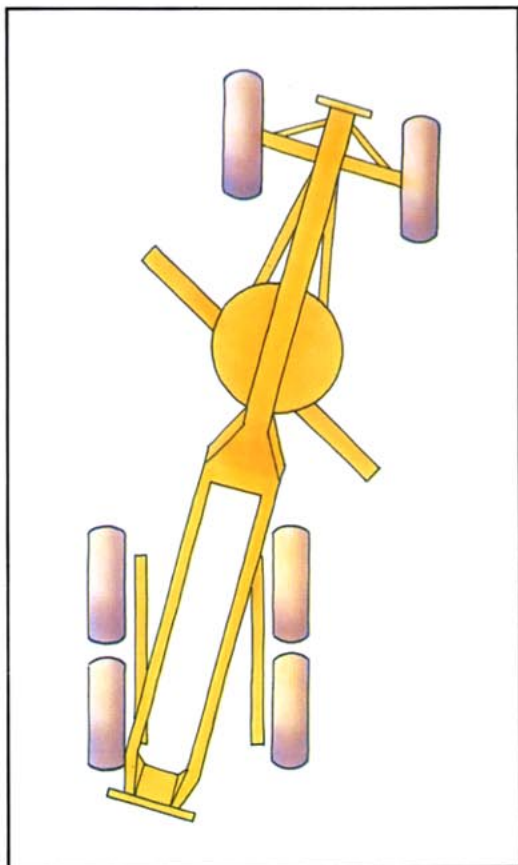

Increased capacity

"Crabbing" enables the operator to straddle windrows, increasing the machine's capacity. Bogie steering also improves the machine stability



Large reach

Reach is a full 2.6 metres (8 ft 6 in), making the 3300 an extremely effective motor grader. Where other machines have to make several passes, the 3300 needs only one.



With a turning radius of only 7.5 metres (25 ft), the 3300 is highly manoeuvrable. Sharp bends can be taken with a full load while the machine is steered with the bogie only.

Sturdy ball bearing race



The steerable bogie is mounted on a sturdy ball bearing race with a diameter of 75 cm. The stresses from the blade are therefore distributed over a large bearing surface, resulting in low wear and less maintenance.

Extra equipment for the 3200 and 3300

Canopy

A rugged structure that can take bumps and knocks and provides good protection against sun and rain. Weight 80 kg (176 lb).



4-wheel brakes

Working on the driving wheels give extra braking capacity.

High capacity hydraulic system

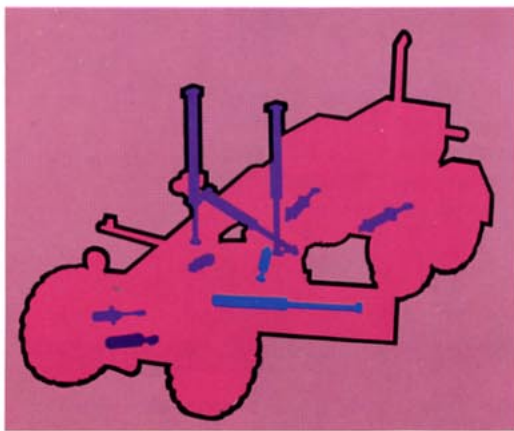

The Volvo BM 3300's hydraulic system has 9 functions, plus front wheel steering, which has a separate steering pump. Three of these are reserve functions for extra equipment, such as front-mounted scarifier.

Hydraulic V-type scarifier



This attachment is mounted in front of the grader blade and is operated hydraulically. On the 3200, an extra hydraulic function must be installed for this attachment if the reserve function is already being used. Stable construction with ripper of Bofors steel. Working width 1 235 mm (4 ft), max. working depth 340 mm (1 ft 1 in). Weight 570 kg (1 256 lb).

Hydraulic blade shift



A feature that greatly boosts the machine's capacity. Connected to free hydraulic function. Weight 95 kg (210 lb).

Hydraulic blade tilt



Permits the cutting angle to be varied during work for fine adjustment of the cutting depth. On the 3200, an extra hydraulic function must be installed if the reserve function is already being used. Weight 60 kg (132 lb).

Extra hydraulic control

Gives the 3200 extra hydraulic manoeuvrability through three additional valve sections. Weight 20 kg. To be used together with the extra hydraulic tube set with two tubes to be mounted on the frame. Weight 10 kg.



The Volvo BM 3300 – a new motor grader with numerous advantages. It has a powerful turbocharged engine and an efficient transmission. Articulated bogie steering provides high manoeuvrability and efficiency at all times. These features, together with ergonomically designed controls, enables the operator to work efficiently and tirelessly.

VOLVO BM
VOLVO BM AB ESKILSTUNA SWEDEN

Under our policy of continual product improvement, we reserve the right to change specifications and design without notice. The illustrations do not necessarily show the standard version of the machine.

Ref.No 21 1 669 1488
ENGELSKA

Production group for basic printed matter Volvo BM