

VOLVO ARTICULATED HAULER

# A25D/A30D

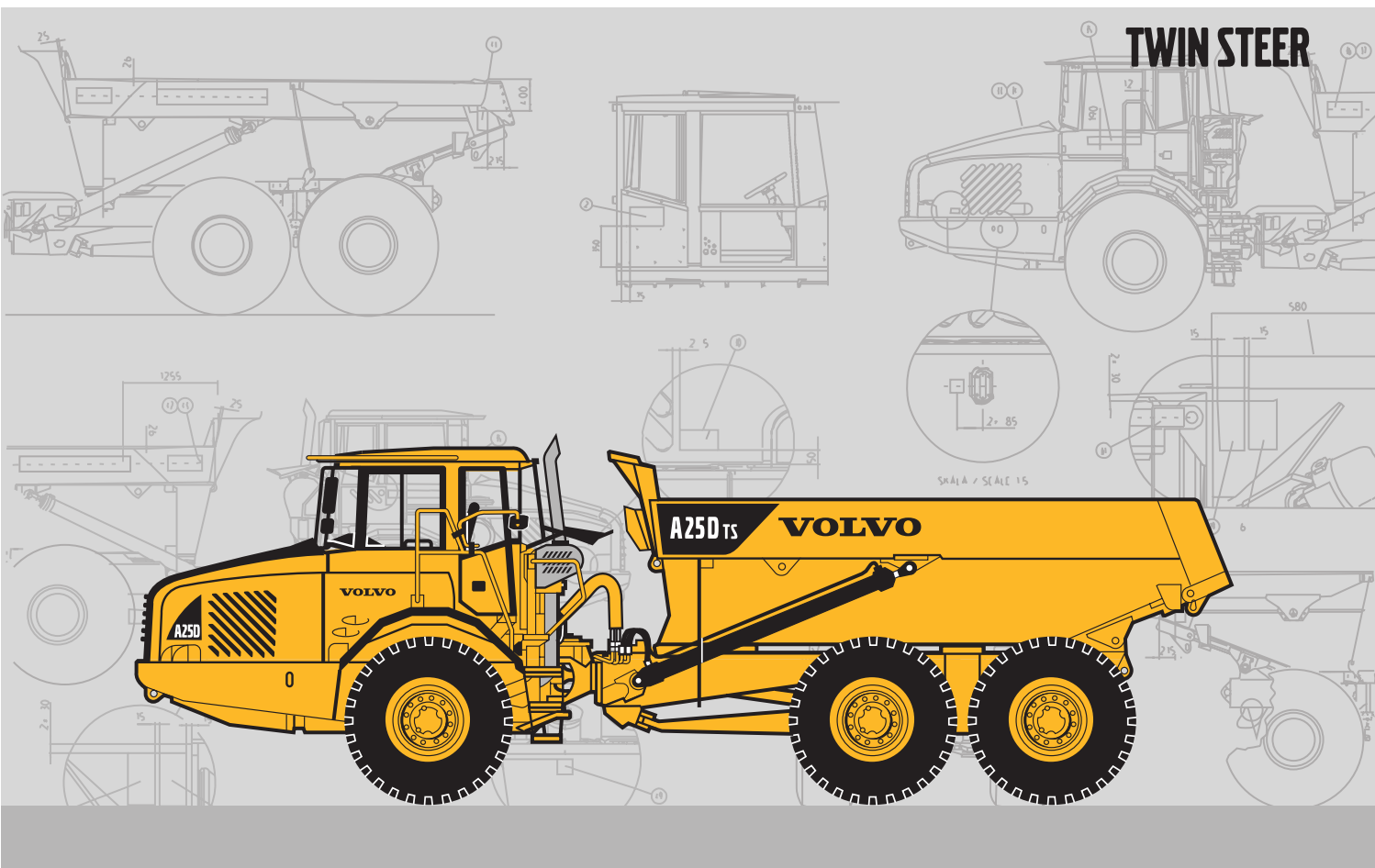

• **Engine output:**

**A25D:**

SAE J1995, Gross 228 kW (310 hp)

SAE J1349, Net 227 kW (309 hp)

**A30D:**

SAE J1995, Gross 242 kW (329 hp)

SAE J1349, Net 241 kW (328 hp)

• **Body volume, heaped:**

**A25D:** 15,0 m<sup>3</sup>

**A30D:** 17,5 m<sup>3</sup>

• **Load capacity:**

**A25D:** 24,0 t

**A30D:** 28,0 t

• **Volvo cab**, designed for high operator visibility, ergonomics and comfort.

• **Reduced maintenance time**, no daily or weekly grease points.

• **Electronic Operator's Communication System**

• **Volvo high performance – low emission** electronically controlled, direct injected, turbocharged, intercooled diesel engine.

• **Fully automatic planetary transmission**, electronically controlled.

• **Hydraulic retarder** integral in transmission.

• **Dropbox with longitudinal differential lock**

• **100% lock-up differentials.** One longitudinal and three transverse differential locks.

• **Front axle with three-point suspension.**

• **Volvo terrain bogie**, individually oscillating axles and high ground clearance.

• **Volvo Load & Dump Brake.**

**VOLVO**

# The A25D - A30D Twin Steer in detail

## Service

The computerized information system monitors all fluid levels, minimizing daily and weekly service times.

Time to next service and the status of vital vehicle systems is shown to the operator on a display in the instrument panel.

**Service accessibility:** Fold-down front grill with access ladder to remote filter bank, located in front of engine.

Large, 90° opening hood for total engine access.

Remote drain hoses and swing-out radiator for easy cleaning.

## Fill capacities

|                          |       |
|--------------------------|-------|
| Crankcase.....           | 38 l  |
| Fuel tank .....          | 400 l |
| Cooling system .....     | 71 l  |
| Transmission total ..... | 41 l  |
| Dropbox.....             | 8,5 l |
| Axles, front/ rear ..... | 33 l  |
| First bogie axle.....    | 34 l  |
| Hydraulic tank .....     | 175 l |

## Engine

Volvo inline 6-cylinder, direct injected electronically controlled, turbocharged, intercooled 4-stroke low-emission diesel engine with wet replaceable cylinder liners.

**Fan:** Hydrostatically driven, thermostatically controlled variable speed radiator fan consuming power only when needed.

**Engine brake:** Exhaust retarder.

## A25D

|                                  |                        |
|----------------------------------|------------------------|
| Make, model .....                | Volvo D10BACE2*        |
| Make, model .....                | Volvo D10BADE2**       |
| Max power at .....               | 33,3 r/s (2 000 r/min) |
| SAE J1995 Gross .....            | 228 kW (310 hp)        |
| Flywheel power at .....          | 33,3 r/s (2 000 r/min) |
| SAE J1349 Net, DIN 6271*** ..... | 227 kW (309 hp)        |
| Max torque at .....              | 22,5 r/s (1 350 r/min) |
| SAE J1995 Gross .....            | 1 375 Nm               |
| SAE J1349 Net, DIN 6271*** ..... | 1 365 Nm               |
| Displacement total .....         | 9,6 l                  |

With fan operating at full speed, the flywheel power is 214 kW (291 hp) and maximum torque is 1 276 Nm which corresponds to DIN 70020.

## A30D

|                                  |                        |
|----------------------------------|------------------------|
| Make, model .....                | Volvo D10BAAE2*        |
| Make, model .....                | Volvo D10BABE2**       |
| Max power at .....               | 33,3 r/s (2 000 r/min) |
| SAE J1995 Gross .....            | 242 kW (329 hp)        |
| Flywheel power at .....          | 33,3 r/s (2 000 r/min) |
| SAE J1349 Net, DIN 6271*** ..... | 241 kW (328 hp)        |
| Max torque at .....              | 22,5 r/s (1 350 r/min) |
| SAE J1995 Gross .....            | 1 420 Nm               |
| SAE J1349 Net, DIN 6271*** ..... | 1 410 Nm               |
| Displacement total .....         | 9,6 l                  |

With fan operating at full speed, the flywheel power is 228 kW (310 hp) and maximum torque is 1 321 Nm which corresponds to DIN 70020.

\*) Meets US (EPA) step 2, California (CARB) step 2 and Europe (EU) step 2.

\*\*) Meets Europe (EU) step 2.

\*\*) with fan at normal speed.



## Electrical system

All cables, sockets and pins are identified.

Cables are enclosed in plastic conduits and secured to main frame.

Halogen lights. Prewired for options.

Connectors meet IP67 standard for water-proofing as necessary.

|                        |                |
|------------------------|----------------|
| Voltage .....          | 24 V           |
| Battery capacity ..... | 2x170 Ah       |
| Alternator.....        | 1,54 kW (55 A) |
| Starter motor.....     | 6,6 kW (9 hp)  |

## Drivetrain

Volvo components, specifically designed for hauler applications.

**Torque converter:** Single-stage with free-wheeling stator and automatic lock-up on all gears.

**Transmission:** Fully automatic planetary transmission with six forward gears and two reverse gears, with a built-in variable hydraulic retarder.

**Dropbox:** Volvo design, single-stage.

**Axles:** Volvo design with fully floating axle shafts and planetary type hub reductions.

**Differential locks:** One longitudinal and three transverse with 100% lock-up function, operator selectable on the move.

**Configuration:** 6x4 or 6x6 drive, operator selectable on the move.

|                           | A25D    | A30D    |
|---------------------------|---------|---------|
| Torque converter.....     | 2,37:1  | 2,37:1  |
| Transmission, Volvo ..... | PT 1560 | PT 1560 |
| Dropbox.....              | IL 1    | IL 1    |
| Axles, Volvo .....        | AH 56   | AH 64   |

## Speed:

| Forward |         |
|---------|---------|
| 1 ..... | 8 km/h  |
| 2 ..... | 12 km/h |
| 3 ..... | 22 km/h |
| 4 ..... | 31 km/h |
| 5 ..... | 40 km/h |
| 6 ..... | 53 km/h |
| Reverse |         |
| 1 ..... | 8 km/h  |
| 2 ..... | 13 km/h |

## Brake system

Dual circuit system with air-hydraulic disc brakes. Meets ISO 3450 and SAE J1473 at total machine weight.

**Service brakes:** Dry discs on all wheels.

**Circuit division:** One circuit for front axle and one for bogie axles.

**Parking brake:** Spring-applied disc brake on the propeller shaft, designed to hold a loaded machine on a grade up to 18%. When the parking brake is applied, the longitudinal differential is locked.

**Compressor:** Gear-driven by engine transmission.

**Retarder:** Hydraulic, infinitely variable, integrated in transmission. Total retarding capability including transmission retarder and exhaust retarder, see graph.

**Steering system with double command:** Hydromechanical self-compensating articulated steering for safe and accurate high-speed hauling. Fast acting, low effort steering with 3,4 turns lock-to-lock for slow speed maneuverability.

The double command makes it possible to turn around the operator's seat and operate the machine in reverse with an extra set of pedals and steering wheel.

Comfort Drive Control for operating in reverse is available as optional equipment.

**Cylinders:** Two double-acting steering cylinders.

**Secondary steering:** Meets ISO 5010 at total machine weight.

**Steering angle:** ±45°

| Weights  |           |           | Ground Pressure  |         |           |                  | Load Capacity                            |                     |                     |
|--|-----------|-----------|--|---------|-----------|------------------|--|---------------------|---------------------|
| Operating weight includes all fluids and operator. |           |           | At 15% sinkage of unloaded radius and specified weights. |         |           |                  | Body volume according to SAE 2:1.        |                     |                     |
|  | A25D      | A30D      |  | A25D    | A30D      |                  |  | A25D                | A30D                |
| Tires  | 23.5R25   | 750/65R25 | Tires  | 23.5R25 | 750/65R25 | 23.5R25          |  |                     |                     |
| <b>Operating weight unloaded</b>                   |           |           | <b>Unloaded</b>  |         |           | <b>Std. Body</b> |  |                     |                     |
| Front  | 12 160 kg | 12 500 kg | Front  | 123 kPa | 101 kPa   | 127 kPa          | Load capacity                            | 24 000 kg           | 28 000 kg           |
| Rear   | 9 400 kg  | 10 560 kg | Rear   | 48 kPa  | 43 kPa    | 54 kPa           | Body, struck                             | 11,7 m <sup>3</sup> | 13,6 m <sup>3</sup> |
| Total  | 21 560 kg | 23 060 kg | <b>Loaded</b>  |         |           | Body, heaped     |  |                     |                     |
| Payload  | 24 000 kg | 28 000 kg | Front  | 144 kPa | 121 kPa   | 152 kPa          | <b>With underhung tailgate</b>           |                     |                     |
| <b>Total weight</b>                                |           |           | Rear   | 159 kPa | 146 kPa   | 183 kPa          | Body, struck                             | 12,0 m <sup>3</sup> | 13,8 m <sup>3</sup> |
| Front  | 14 140 kg | 14 990 kg |  |         |           |                  | Body, heaped                             | 15,3 m <sup>3</sup> | 18,0 m <sup>3</sup> |
| Rear   | 31 420 kg | 36 070 kg |  |         |           |                  | <b>With overhung tailgate</b>            |                     |                     |
| Total  | 45 560 kg | 51 060 kg |  |         |           |                  | Body, struck                             | 12,1 m <sup>3</sup> | 14,0 m <sup>3</sup> |
|  |           |           |  |         |           |                  | Body, heaped                             | 15,6 m <sup>3</sup> | 18,1 m <sup>3</sup> |
|  |           |           |  |         |           |                  | <b>With over and under hung tailgate</b> |                     |                     |
|  |           |           |  |         |           |                  | Body, struck                             | 12,1 m <sup>3</sup> | --                  |
|  |           |           |  |         |           |                  | Body, heaped                             | 15,6 m <sup>3</sup> | --                  |

### Suspension

Volvo's unique maintenance-free 3-point suspension system. The axles are suspended at three points, which results in independent movement needed in rough terrain.

**Front axle:** One hollow rubber spring on each side. A cross stay provides the stability. Two shock absorbers on each side.

**Bogie:** Volvo's unique terrain bogie permits long suspension travel and independent wheel movement, keeps the body level, retaining the load.

### Cab

Volvo cab, ergonomically designed for high operator comfort and excellent visibility. Wide threshold-free door opening and ergonomic cab entrance. Insulating rubber pads to reduce vibrations. Tilt/ telescopic steering wheel. Overhead console for radio and storage. Dash-mounted Operator's Communication System. Storage bins.

**Standard:** ROPS/FOPS tested and approved. (ISO 3471, SAE J1040) / (ISO 3449, SAE J231) standards.

**Heater and defroster:** Filtered fresh air, four-speed fan and pressurized cab to maintain a clean operating environment. Multi-level air outlets and separate defroster vents for all windows.

**Operator's seat:** Adjustable operator's seat with flameproof upholstery. Retractable seat belt. Sound level in cab, ISO 6396 74 dB (A)

### Hydraulic system

Load-sensing, variable displacement, piston pumps, consume power only when needed.

**Pumps:** Four engine-driven variable displacement load-sensing piston pumps driven by the flywheel PTO. One ground-dependent piston pump for secondary steering mounted on the dropbox.

**Filter:** One fibreglass filter with magnetic core.

### Pump capacity per pump:

Engine-dependent..... 140 l/min  
Ground-dependent ..... 142 l/min  
at shaft speed ..... 52,5 r/s (3 150 r/min)  
Working pressure ..... 25 MPa

### Body

**Load and dump brake:** With the engine running, the service brakes on bogie axles are applied and transmission is shifted to neutral.

**Body material:** Hardened and tempered steel body, flat plate design made of high-strength steel.

Front ..... 8 mm  
Sides ..... 12 mm  
Bottom ..... 14 mm  
Chute ..... 14 mm  
Yield strength ..... 900 N/mm<sup>2</sup>  
Tensile strength ..... 1 250 N/mm<sup>2</sup>  
Hardness min ..... 360 HB

**Dump Cylinders:** Two single-stage double-acting cylinders.

**A25D      A30D**

Tipping angle ..... 74° ..... 70°  
Tipping time with load ..... 12 s ..... 12 s  
Lowering time ..... 9 s ..... 9 s

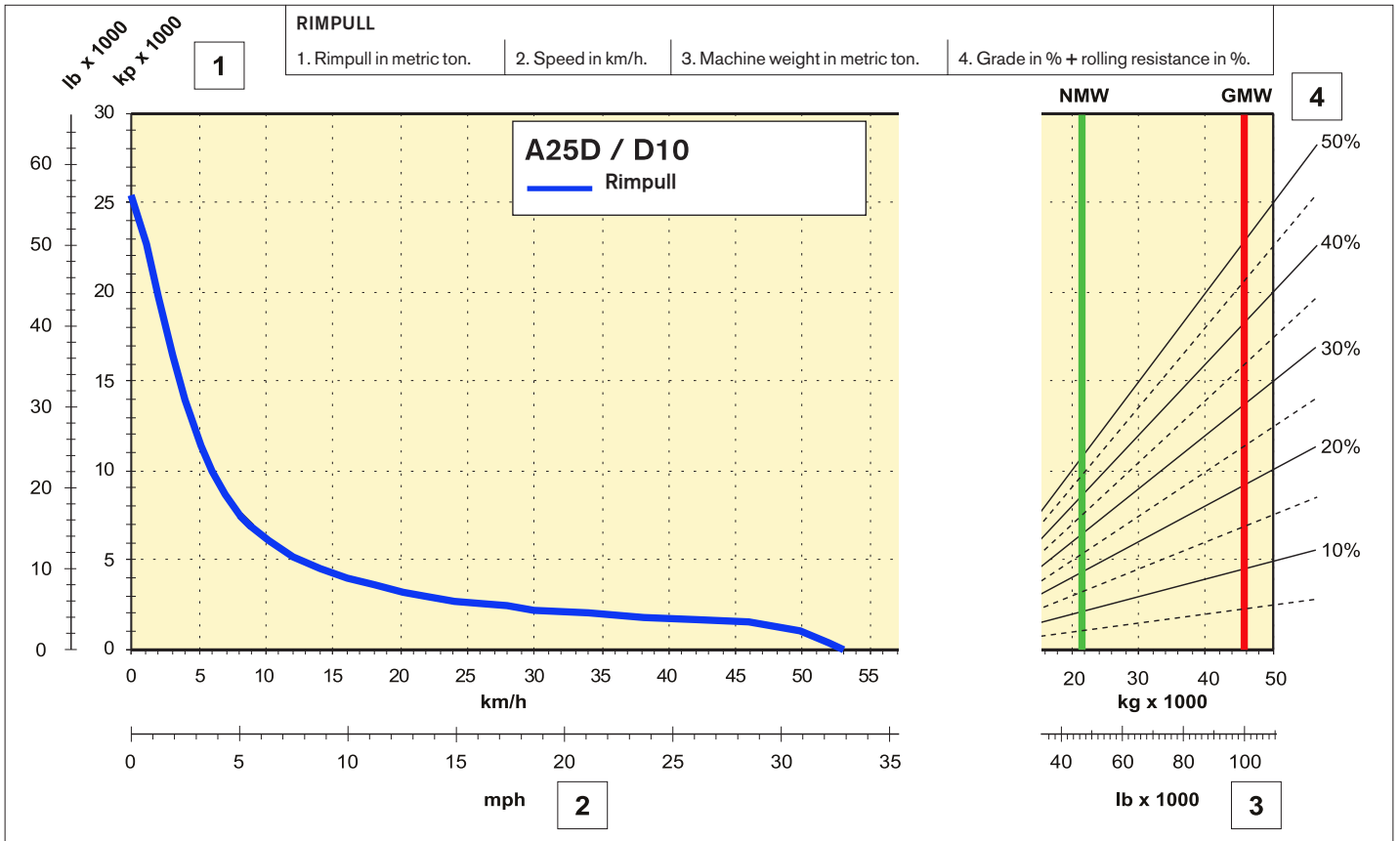

**Instructions**

Diagonal lines represent total resistance (grade % ± rolling resistance %). Charts based on 0% rolling resistance, standard tires and gearing, unless otherwise stated.

- Find the diagonal line with the appropriate total resistance on the right-hand edge of the chart.
- Follow the diagonal line downward until it intersects the actual machine weight line, NMW or GMW.
- Draw a new line horizontally to the left from the point of intersection until the new line intersects the rimpull or retardation curve.
- Read down for vehicle speed.

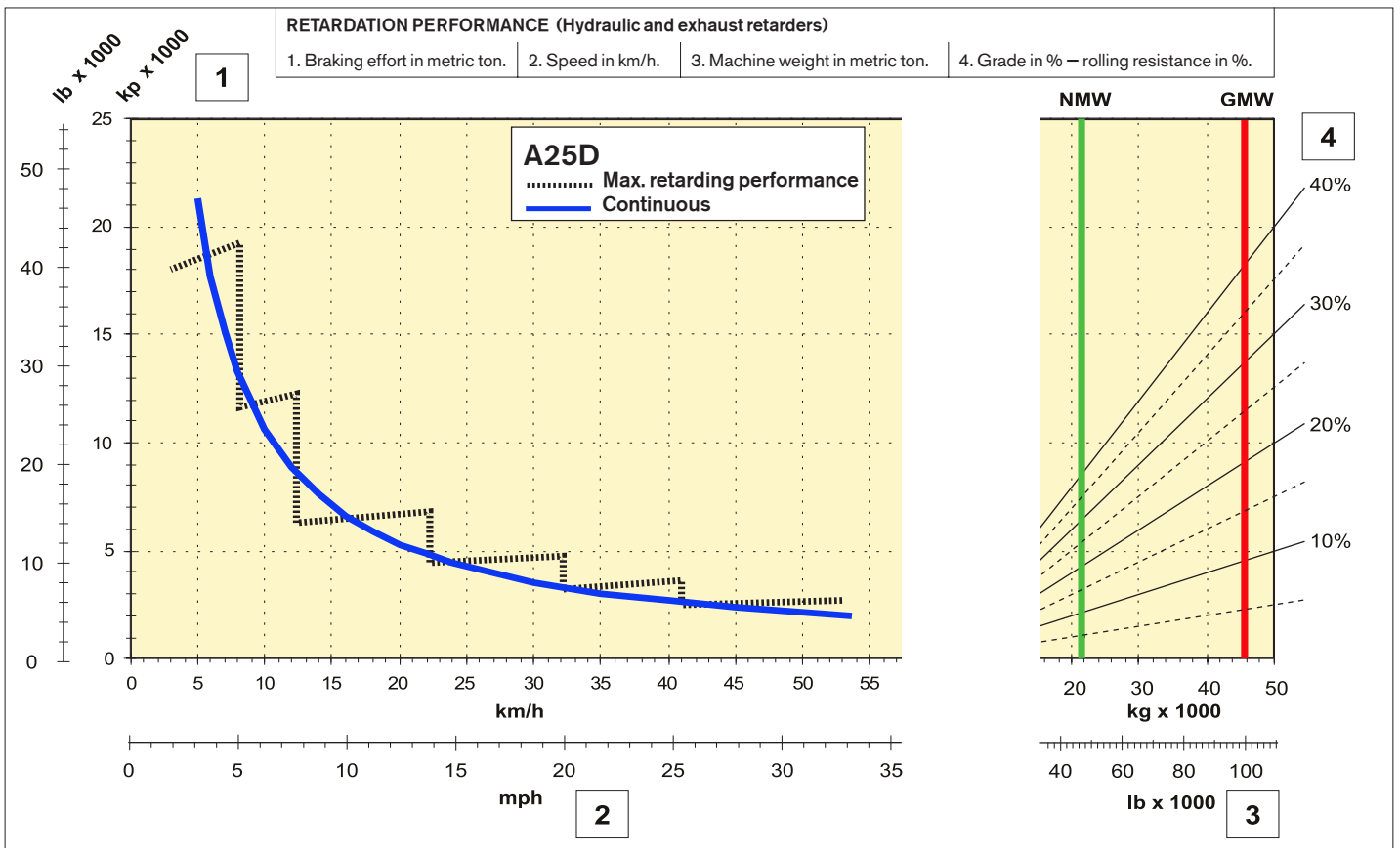

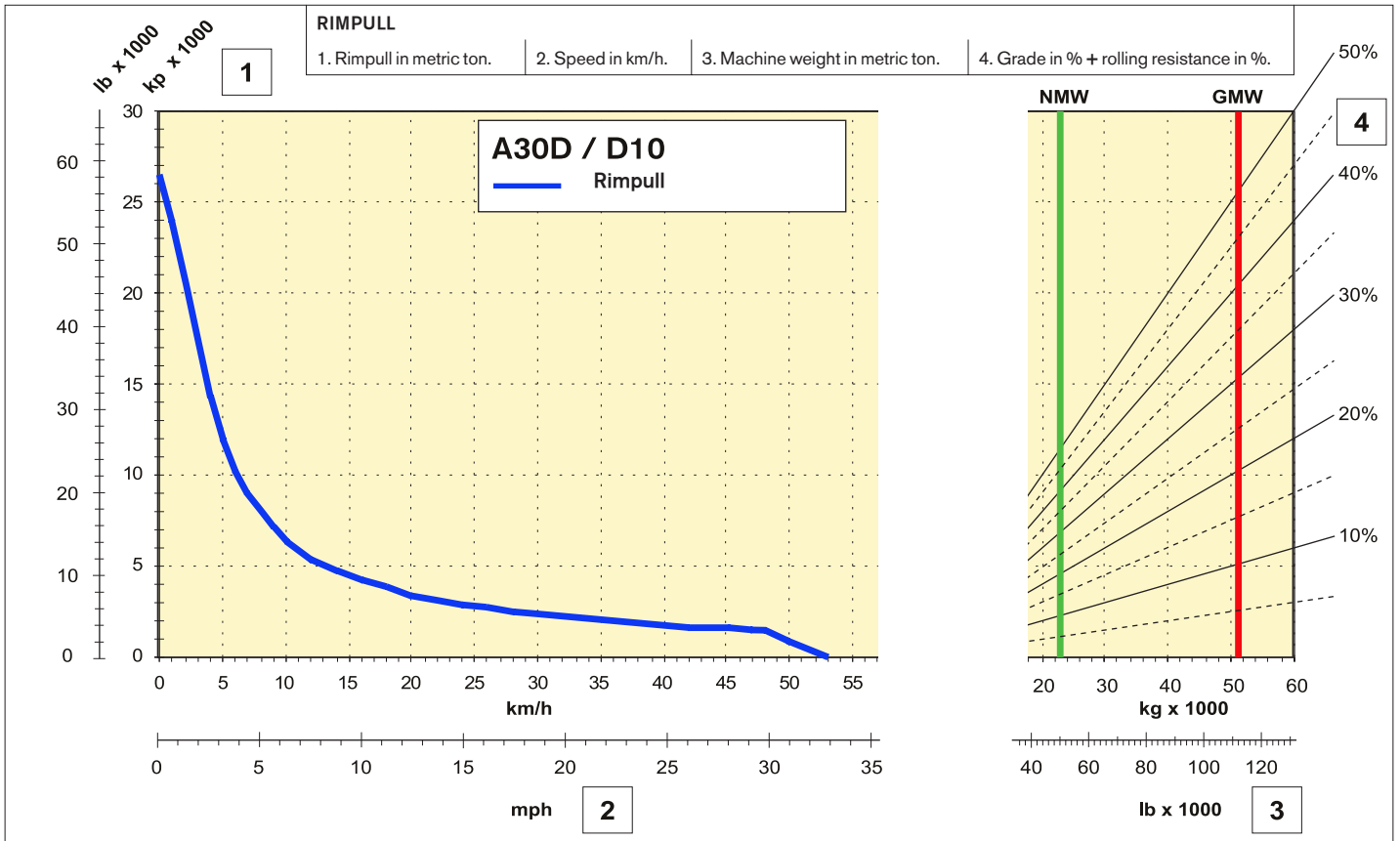

**Instructions**

Diagonal lines represent total resistance (grade % ± rolling resistance %). Charts based on 0% rolling resistance, standard tires and gearing, unless otherwise stated.

- Find the diagonal line with the appropriate total resistance on the right-hand edge of the chart.
- Follow the diagonal line downward until it intersects the actual machine weight line, NMW or GMW.
- Draw a new line horizontally to the left from the point of intersection until the new line intersects the rimpull or retardation curve.
- Read down for vehicle speed.

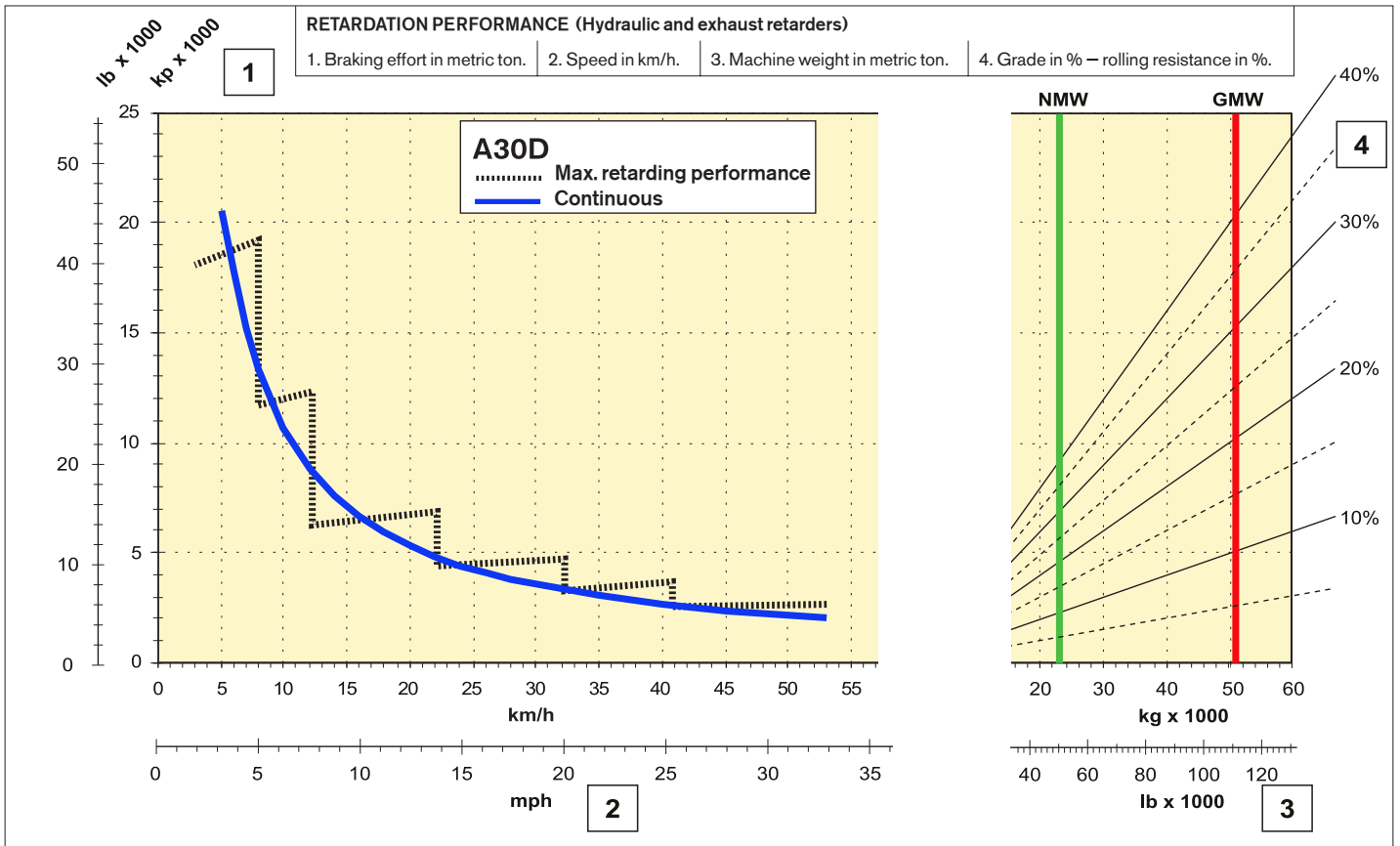

# Specifications A25D - A30D Twin Steer

| Pos            | Metric (mm) |        | Imperial (feet) |        |
|----------------|-------------|--------|-----------------|--------|
|                | A25D        | A30D   | A25D            | A30D   |
| A              | 10 220      | 10 297 | 33'6"           | 33'9"  |
| A <sub>1</sub> | 4 954       | 4 954  | 16'3"           | 16'3"  |
| A <sub>2</sub> | 5 764       | 6 002  | 18'11"          | 19'8"  |
| B              | 5 152       | 5 339  | 16'11"          | 17'6"  |
| C              | 3 428       | 3 428  | 11'3"           | 11'3"  |
| C <sub>1</sub> | 3 318       | 3 318  | 10'11"          | 10'11" |
| C <sub>2</sub> | 1 768       | 1 768  | 5'10"           | 5'10"  |
| C <sub>3</sub> | 3 760       | 3 834  | 12'4"           | 12'7"  |
| D              | 2 764       | 2 764  | 9'1"            | 9'1"   |
| E              | 1 210       | 1 210  | 4'0"            | 4'0"   |
| F              | 4 175       | 4 175  | 13'8"           | 13'8"  |
| G              | 1 670       | 1 670  | 5'6"            | 5'6"   |
| H              | 1 610       | 1 688  | 5'3"            | 5'6"   |
| I              | 608         | 608    | 2'0"            | 2'0"   |
| J              | 2 778       | 2 856  | 9'1"            | 9'4"   |
| K              | 2 102       | 2 181  | 6'11"           | 7'2"   |
| L              | 677         | 686    | 2'3"            | 2'3"   |
| M              | 6 559       | 6 592  | 21'6"           | 21'8"  |
| N              | 8 105       | 8 105  | 26'7"           | 26'7"  |
| N <sub>1</sub> | 4 079       | 4 037  | 13'5"           | 13'3"  |
| O              | 2 700       | 2 900  | 8'10"           | 9'6"   |
| P              | 2 490       | 2 706  | 8'2"            | 8'11"  |
| R              | 512         | 513    | 1'8"            | 1'8"   |
| R <sub>1</sub> | 634         | 635    | 2'1"            | 2'1"   |
| U              | 3 257       | 3 310  | 10'8"           | 10'10" |
| V              | 2 258       | 2 216  | 7'5"            | 7'3"   |
| V*             | -----       | 2 258  | -----           | 7'5"   |
| W              | 2 859       | 2 941  | 9'5"            | 9'8"   |
| W*             | -----       | 2 859  | -----           | 9'5"   |
| X              | 456         | 456    | 1'6"            | 1'6"   |
| X <sub>1</sub> | 581         | 582    | 1'11"           | 1'11"  |
| X <sub>2</sub> | 659         | 659    | 2'2"            | 2'2"   |
| Y              | 2 258       | 2 216  | 7'5"            | 7'3"   |
| Y*             | -----       | 2 258  | -----           | 7'5"   |
| Z              | 2 859       | 2 941  | 9'5"            | 9'8"   |
| Z*             | -----       | 2 859  | -----           | 9'5"   |
| a <sub>1</sub> | 23,5°       | 23,5°  | 23,5°           | 23,5°  |
| a <sub>2</sub> | 74°         | 70°    | 74°             | 70°    |
| a <sub>3</sub> | 45°         | 45°    | 45°             | 45°    |

A25D: Unloaded machine with 23,5R25  
A30D: Unloaded machine with 750/65R25  
\* A30D with optional 23,5R25 tires

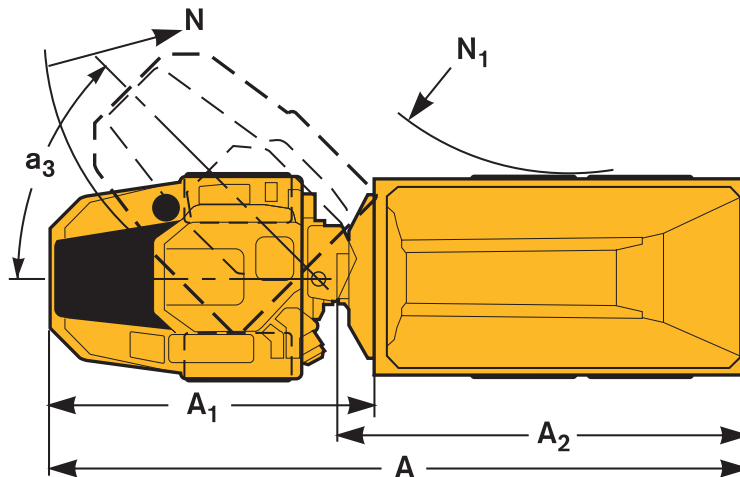
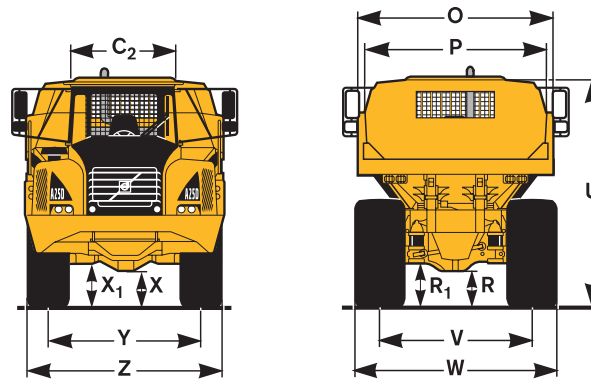
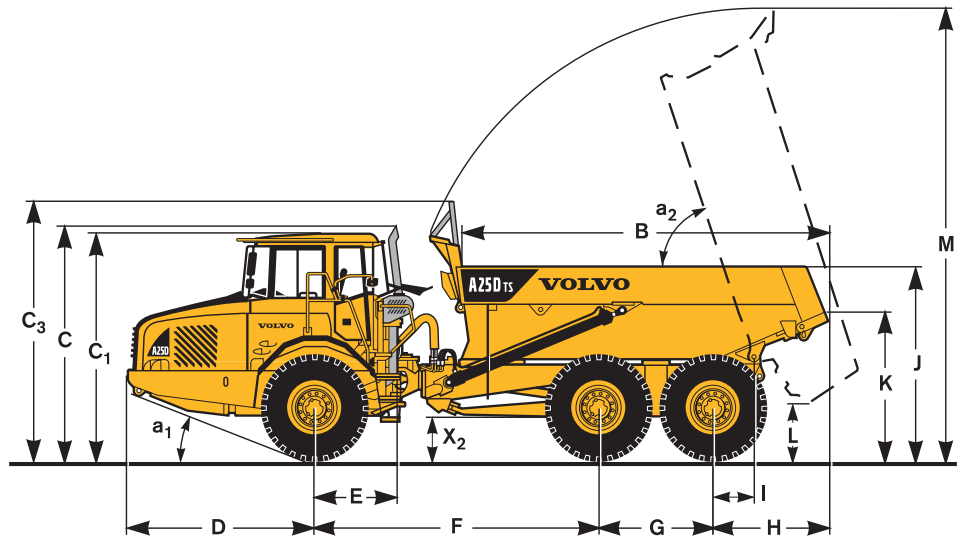



## STANDARD EQUIPMENT

### Safety

ROPS/ FOPS protected cab  
Service platform for ease of service  
Anti-slip material on hood and fenders  
Hazard lights  
Horn  
Protective grille for rear window  
Rear-view mirrors, forward and reverse  
Secondary steering  
Retractable 3-inch safety belt  
Steering joint locking assembly  
Dump body lock  
Windshield wipers and washers for front wind-  
shield and rear window  
Exhaust pipe moved for reverse travelling

### Comfort

Two adjustable steering wheels for operation in  
both directions  
Throttle pedal for reverse travelling  
Brake pedal for reverse travelling  
Cab heater with filtered fresh air and defroster  
Overhead console for radio and storage  
Sun visor  
Tinted glass  
Can holder /storage tray  
Cigarette lighter  
Ashtray  
Space for lunch cooler  
Storage box  
Reversible operator's seat for operation in both  
directions

### Engine

Direct injected, electronically controlled  
Turbocharged, intercooled  
Remote oil drain plug  
Remote oil filters, for ease of access  
Preheater for easier cold starts

### Electrical system

55 A alternator  
Battery disconnect switch  
Extra 24 V socket for lunch cooler

#### Lights:

- Headlights
- Parking lights
- Direction indicators
- Rear lights
- Back-up lights
- Extra back-up lights
- Work lights, rear-facing, mounted on mudguard
- Rotating beacon mounted under load body
- Brake lights
- Cab lighting
- Instrument lighting

### Operator information interface

#### Gauges:

- Speedometer
  - Tachometer
  - Brake pressure
  - Fuel
  - Transmission oil temperature
- Pilot lights for all switches  
Warning lights grouped and easy to read  
Central warning (3 levels) for all vital functions  
Extra Central warning light, visible during reverse  
operation  
Central positioned information display:
- Automatic pre-start checks
  - Operation information, easy-to-find menu
  - Troubleshooting diagnostics
  - Hour meter
  - Clock
  - Machine settings

### Drivetrain

Automatic transmission  
Torque converter with automatic lock-up  
Dropbox, single-stage  
6x4 or 6x6 operator selectable drive modes  
Hydraulic variable retarder  
100% longitudinal differential lock  
100% differential locks in all axles

### Brakes

Air-hydraulic disc brakes  
Two circuit brake system  
Parking brake on prop shaft

### Body

Body prepared for exhaust heating  
Load and Dump brake  
Sight hole with protective grille in load body

### Tires

A25D: 23,5R25  
A30D: 750/65R25

### Other

Air drier

(\* Special Standard Equipment)

## OPTIONAL EQUIPMENT

### Safety

Fire-extinguisher and first aid kit  
Secondary steering for reverse operation

### Service and maintenance

Tool kit with tire inflation unit  
Electrical hood opening

### Engine

Extra air cleaner, heavy-duty  
Extra air cleaner, oil bath type  
External emergency engine stop  
Delayed engine stop  
Electric engine heater (120V or 240V)  
Engine and cab heater, diesel \*\*  
Fuel filter heater, electrical, 24V \*\*  
Fast fuel filling system \*\*

### Electrical

Work lights, roof-mounted  
Work lights, rear-facing, fender-mounted  
Work lights (distance lights) on cab roof \*\*  
Rotating beacon, collapsible mount  
Rotating beacon, extra  
Back-up alarm  
Rear vision system, monitor located by rear  
window, improves visibility for reverse operation  
Anti-theft system (prevents engine start)  
Headlights for left-hand traffic  
Alternator, heavy-duty 80 A  
Battery charger \*\*  
Jump start connection, NATO \*\*  
Back up light, extra \*\*  
Cab heater, electrical \*\*

### Cab

Air suspended, electrically heated operator's seat  
Seat cover \*\*  
Armrests prepared for joysticks \*\*  
Instructor seat with seat belt  
Electrically heated rear-view mirrors  
Air conditioning  
Radio installation kit  
Radio  
Cable kit for cab heater (120V or 240V)  
Window tint film  
Comfort Drive Control for reverse operation  
Vandalism protection for cab windows \*\*  
Rear-view mirror, close up \*\*  
Lowered cab roof  
Roof rack \*\*

### Body

Body exhaust heating kit

A25D  
Underhung tailgate, link operated  
Overhung tailgate, link operated (only in combina-  
tion with underhung gate)  
Overhung tailgate, wire operated

A30D  
Underhung tailgate, link operated  
Overhung tailgate, wire operated

Wear plates  
Extra front spillguard  
Upper side extension, 200 mm

### Attachments

Light Material body (0,9 t/m<sup>3</sup>) \*\*  
Flat loading platform without dumping function \*\*

### Tires

A25D: 650/65 R25  
A30D: 23,5R25

### External

Rear mudflaps  
Belly plates for trailer A-stay \*\*  
Increased bogie axle distance, 50mm \*\*  
Additional front bumper (rubber)

### Other

Synthetic hydraulic oil (biologically degradable)  
Arctic oil kit  
Toolbox  
Non-skid chain modification, front unit \*\*  
Non-skid chain storing hooks \*\*

(\* \* Special Optional Equipment)

*Under our policy of continual product improvement, we reserve the right to change specifications and design without prior notice. The illustrations do not necessarily show the standard version of the machine.*

**VOLVO**

**Construction Equipment**

Ref. No 21 2 669 4160 English  
Sweden 2002-04 ART  
Volvo Växjö