

VOLVO EXCAVATORS

**EC140/EC290
EC360/EC460**

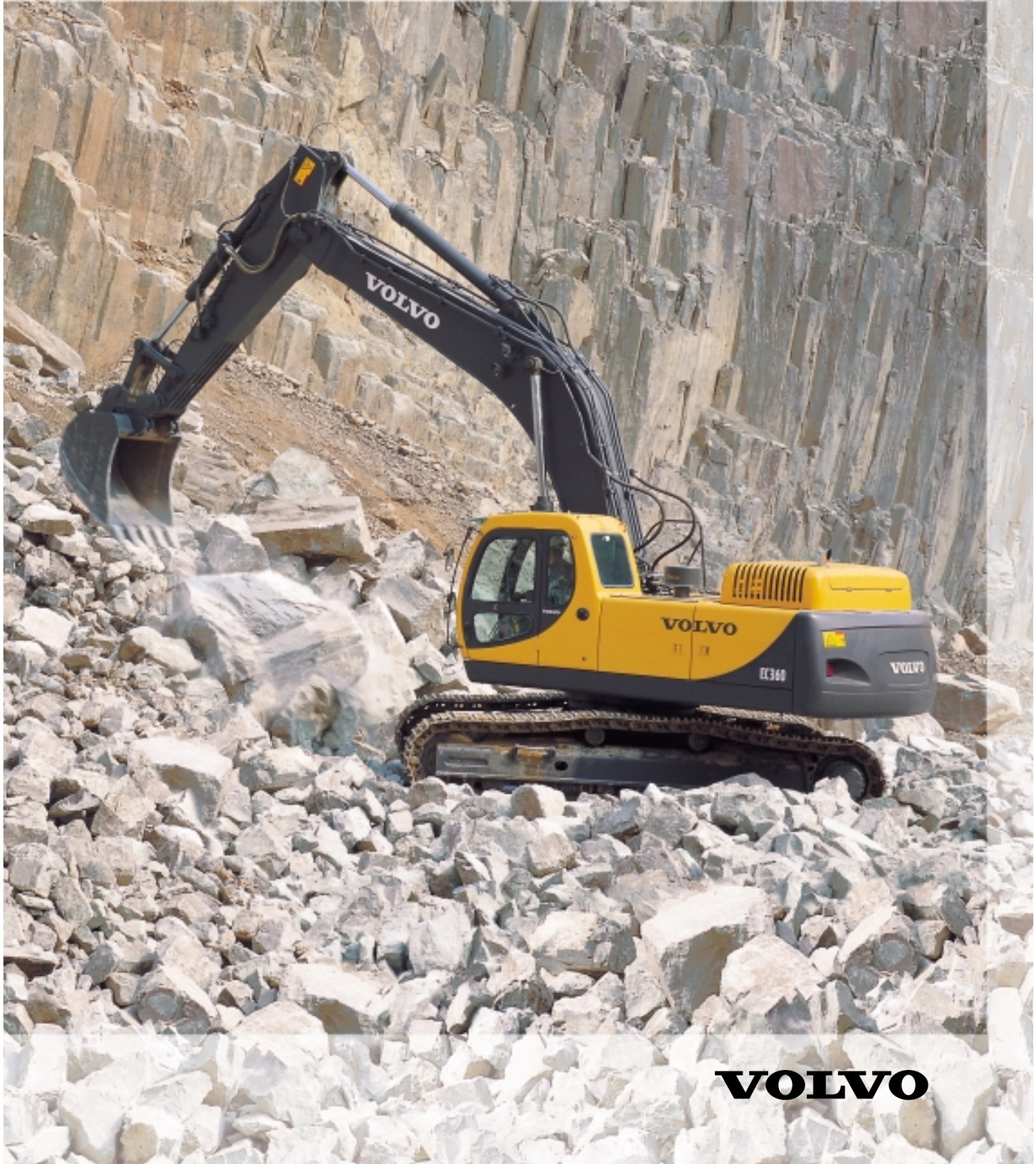

VOLVO

Powerful Reliable Proven high performance Comfort and safety

Volvo Excavators are designed for the worldwide market. The advanced technology incorporated into every Volvo excavator works behind the scenes... It is invisible to the operator, with the net result being, a machine with incredible power, smoothness, versatility and simplicity.

High performance and productivity

The first critical ingredient for performance and productivity is engine horsepower. The diesel engines in Volvo excavators have among the highest horsepower ratings in their size classes. Volvo Excavators use the proven and reliable Cummins diesel engines in all models of our excavators, which are recognized worldwide for their efficiency and durability.

The second critical ingredient is hydraulic oil flow. The maximum hydraulic oil flow ratings on Volvo excavators are among the highest in their respective size classes also.





Hydraulic system

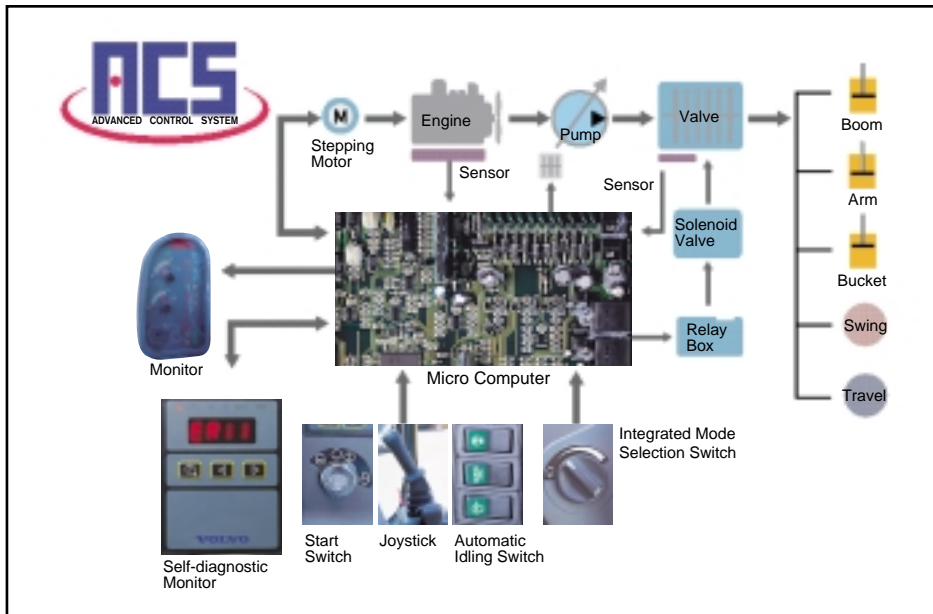

ACS, or the Advanced Control System, is Volvo's exclusive intelligent operating control system. It has five power mode selections available with 10 different engine RPM settings. The power modes, "H", "G", "F", and "I" are suitable for many different job site conditions, and if you need maximum engine power, select the new "Power Max mode", and you will have access to the highest production available from the new Volvo excavators. For tough jobs, when extra power is needed, operators have a convenient Power Boost Mode available. Power boost raises the main relief pressure for the boom, arm, and bucket circuits to 350 bar for nine seconds. This allows the operator to get the job done without slowing down the work cycle. It is simple and efficient. ACS even features a self-diagnostic system that automatically checks the machines vital functions. If there are malfunctions, the operator instantly knows

what the problem is.

The boom, arm and swing priority systems are automatic. There are no switches to activate. The machine "knows" what to do based on the joystick movements of the operator.

The main hydraulic control valve assembly has been designed specifically for our excavators. Its multi-functional design, with two separate valve banks, makes it possible to perform a variety of operations simultaneously.

The Volvo hydraulic system has many other high tech features also. There is a "standard" auxiliary control valve spool for quick installation of factory or after-market equipment. An automatic, 2-speed travel function adjusts travel speed and tractive forces to terrain conditions. The straight travel function lets you operate the boom, arm or bucket circuits while travelling without worrying about travel drift.

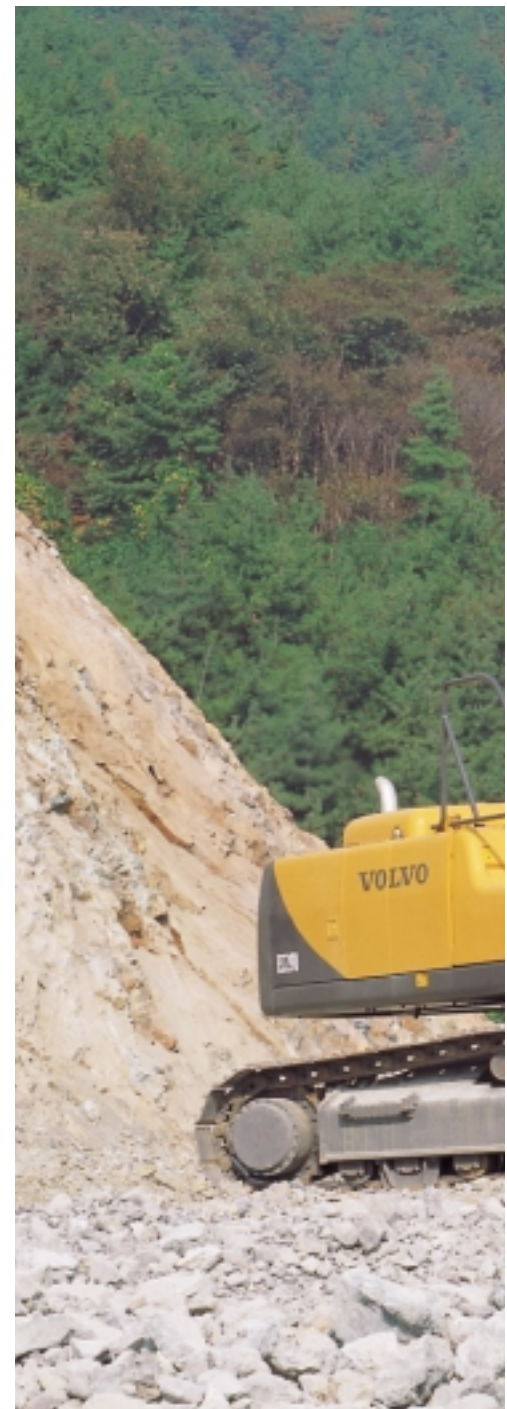

Operator comfort



The large cab door opens wide to allow the operator to enter the cab easily. Well-placed steps and handrails facilitate a safe entrance and exit.

Good all-round visibility is obtained through large, laminated cab windows. The clear roof hatch and sliding rear window provide the operator with exceptional comfort and visibility. Footrests are right where you need them. Even the travel pedals have been fitted with dampening valves for superior smoothness and sensitivity during operation.

The new heated seat has both spring suspension and shock absorption, with 8 different adjustments possible. Well-placed adjustment controls are easy to understand and use.

The backrest and arm rests adapt easily to the operators size and weight.

An additional operator comfort item available includes an air suspension system for the seat.

High quality sound absorption materials inside the cab and engine compartment reduce sound levels to a minimum.

Another standard feature is the large storage area, located behind the operator's seat, which provides room for manuals and the operator's lunch.

Cab and operator protection systems available for the Volvo excavators include FOGS (Falling Object Guards), FOPS (Falling Object Protection), safety meshes for the front window, as well as vandalism protection guards.



Service & maintenance

Many of the diagnostics are right in front of the operator within the cab.

A battery disconnect switch, located in the battery compartment, prevents unauthorized personnel from starting the engine.



In addition, well-placed steps & handrails, as well as non-slip punched plate walk areas promote safety.

Another Volvo exclusive is the Excaliever system analyzer, which gives service technicians detailed diagnostic system information for quick onsite service.

The in-line hydraulic cooler for EC290 can be tilted out, which increases accessibility, and therefore makes cleaning easier.

With the environment in mind, the engine oil pan has been equipped with a quick coupler that allows a drain hose to be easily connected.

Remote greasing points for the boom and arm are grouped together for operator convenience. These centralized lubrication points can reduce overall maintenance time. Bucket pins are double sealed to keep grease in and water and dirt out.

Digging equipment

Volvo manufactures its own hydraulic cylinders, with built-in cushions, to insure long life and smooth operation.

Over-sized cylinder bushings practically eliminate play, which means lower maintenance costs.

Booms, arms, and other structural components are all precision-welded using state of the art robotics to ensure consistent quality and durability.

Volvo provides a wide range of boom and arm combinations to suit the customer's needs for reach and productivity.

Depending upon the configuration, the Volvo excavator can achieve outstanding digging forces and high productivity.

In addition, the digging geometry is perfect for deep vertical digging, maximum dumping height, as well as machine transportation height.

Undercarriage

The strong, rugged frame is constructed from high tensile strength steel, and robotically welded for consistent quality and reliability.

The track frames are tapered so that mud and debris slides off easily.

The travel motors are located within the width of the frame and tracks for protection. Track pins and bushings are greased and sealed to reduce travel noise and extend their life, which adds even more value to the Volvo excavator. This undercarriage is built and assembled in a state of the art facility and will stand up to the most extreme work-site conditions. There are many different track shoe sizes available, with even rubber or swamp shoes also available for some models.



Volvo quick fit

The Volvo quick fit is a proven, durable and reliable system, which will give operators the added versatility they demand in today's excavator. To be able to quickly release and drop one bucket and install another one without leaving the cab is a considerable advantage over a direct-fit style bucket. Once the control switches in the cab are activated, a hydraulic cylinder extends a locking wedge under the hook on the bucket and securely holds the bucket in place. This cylinder is also under constant pressure, so that as the operator works, the bucket actually gets tighter, instead of looser, like the competitions. The lifting hook is also mounted on the quick fit and not the bucket, so the operator can just drop the bucket and immediately gain the weight of the bucket in lift capacity. Plus, he has greater visibility while performing lifting operations.





Many optional items



The Volvo excavator can be ordered with many different attachment configurations. Additionally, hydraulic piping kits for hammer, shear, or clamshell are available, either as standard or optional equipment for many different machine applications. These are among the features that can make the Volvo excavator your best choice. These features create the added value that makes our excavators and your operator more efficient, more productive, and more profitable.





*Under our policy of continuous improvement, we reserve the right to change specifications and design without prior notice.
The illustrations do not necessarily show the standard version of the machine.*

VOLVO

**Volvo Construction
Equipment Group**

Ref. No. 21 1 435 1107
Printed in Korea 1999.12.3
Volvo, Seoul

English, global
KOR