

**VOLVO EXCAVATOR**

# EW140

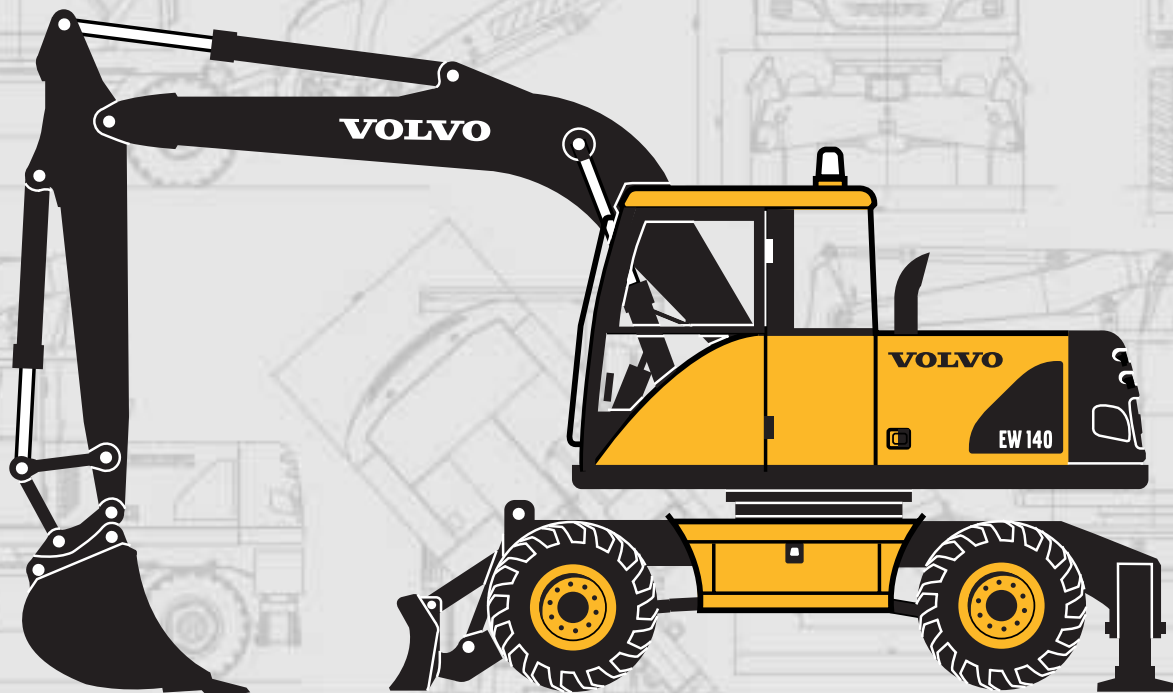

- **Engine Power, gross:**  
76,5 kW (104 hp)
- **Operating Weight:**
- **Buckets:**  
190 - 750 l
- Low emission, turbocharged, diesel engine with direct injection
- Load sensing hydraulic system
- Care cab
  - computerized control and warning system
  - ergonomic environment
  - low sound level
  - filtered air
- Individually operated outriggers and dozer blade
- Highest versatility for extra equipment / hydraulics
- High travel speed – 30,0 km/h

**VOLVO**



## ENGINE

The engine is a low emission, turbocharged, 4-stroke diesel engine with water cooling, direct injection.

Model.....	TD40 GHE
Output at.....	36,7 r/s (2 200 r/min)
Net (ISO 9249/DIN 6271) .....	75,5 kW (103 hp)
Gross (SAE J1349).....	76,5 kW (104 hp)
No. of cylinders .....	4
Displacement, total.....	4,0 l
Bore .....	100 mm
Stroke .....	127 mm



## ELECTRICAL SYSTEM

Micro processor for monitoring of engine and hydraulic system. High capacity and well protected electrical system. Printed, circuit board based electric central with clearly arranged fuses and relays. Central prepared for connecting optional equipment. Battery disconnecter standard.

Voltage.....	24 V
Battery .....	2 x 12 V
Battery capacity .....	100 Ah
A.C. Generator .....	28 V / 55 A
Alternator rating.....	1 540 W



## SLEWING SYSTEM

The superstructure is slewed by a direct working radial piston motor with integrated slew holding brake.

Slew speed .....	10 r/min
------------------	----------



## CARE CAB

Operator's cab with a supporting frame structure. Large panes for good all round visibility. The upper front pane can be pushed up into the ceiling. Sliding side window in the cab door.

**Heater and defroster:** A fan provides filtered air and efficient heating. Prepared for Air Conditioning.

**Operator's seat:** Adjustable suspension operator's seat and individually adjustable armrest.

### Sound pressure level: 73 dB(A)

Low internal noise with a sound pressure level of 73 dB(A), resulting in the German certification «Blue Angel» environmental seal awarded for low noise emissions. (RAL-UZ53) Noise ratings acc. to Directive 86/662 EEC.



## UNDERCARRIAGE

**Drive train:** One big variable axial-piston motor on the two-step Power Shift gearbox gives power to front and rear axles, both with hub reductions.

**Framework:** All-welded robust torsion box frame.

**Wheels:** Alternative single and twin wheels available.

**Front axle:** 18 t excavator axle with automatic or operator controlled front axle oscillation lock. Oscillating  $\pm 9^\circ$ .

Twin wheels.....	10.00–20
Max. tractive force (gross) .....	82 kN
Max. tractive force (net).....	74 kN
Travel speed, road travel.....	30,0 km/h
Travel speed, site travel.....	8,0 km/h
Travel speed, creeping travel.....	4,0 km/h
Turning radius, front wheels .....	6,8 m
System pressure .....	35 MPa



## BRAKES

Brake system corresponds to ISO 3450.

**Travel brakes:** servo-hydraulically manoeuvred self-adjusting wet multidiscs in two separate brake circuits.

**Parking brake:** negative wet disc in gear housing, spring applied and pressure released.

**Digging brake:** use travel brakes.

**Security system:** The 2-circuit travel brakes are supplied with two accumulators in the event of failure in the service brake system.



## WEIGHT AND AXLE LOAD

Machine with **4,5 m monobloc boom**, 2,45 m dipper arm, quickfit S6, 530 kg / 1100 mm bucket, twin tires and fuel tank level of 75 %.

\* Machine with **4,7 m 2-piece boom**, 2,45 m dipper arm, quickfit S6, 530 kg / 1100 mm bucket, twin tires and fuel tank level of 75 %.

Total machine weight incl. blade and outriggers .....	14 950 kg	15 050 kg*
Axle load		
Front axle .....	7 390 kg	6 610 kg*
Rear axle.....	7 560 kg	8 440 kg*

Total machine weight incl. support blade (excl. outriggers).....	13 850 kg	13 950 kg*
Axle load		
Front axle .....	6 350 kg	5 320 kg*
Rear axle.....	7 500 kg	8 630 kg*



## SERVICE REFILL CAPACITIES

Fuel tank .....	250 l
Hydraulic system, total .....	235 l
Hydraulic oil tank, max.....	145 l
Diesel engine oil.....	8,1 l
Cooling system (incl. glycol) .....	26 l
Transmission .....	3,4 l



## HYDRAULIC SYSTEM

Closed-centre system with load sensing and pressure compensated valves. High pump capacity for fast movements and excellent manoeuvrability. The system gives good working result and economy. It can easily be adapted for extra equipment.

The following working modes are included in the system:

**Heavy mode:** (H) Used for normal work for best speed utilization.

**Fine control mode:** (F) Reduces the speed at fine adjustment and improves manoeuvring precision.

**Customised mode:** (C) The operator can set proper hydraulic flow/engine revs.

**Power Boost:** All digging, lifting and tractive forces increase for 10 seconds.

For optimum utilization of the engine electronically controlled pump regulation is included in the system.

**Working pump**  
 Max. pressure ..... 32 MPa  
 Max. pressure with Power Boost... 35 MPa  
 Max. flow..... 220 l/min

**Servo pump**  
 Pressure..... 3,5 MPa  
 Flow..... 15 l/min

**Fan pump**  
 Pressure..... 17 MPa  
 Flow..... 35 l/min

## DIMENSIONS

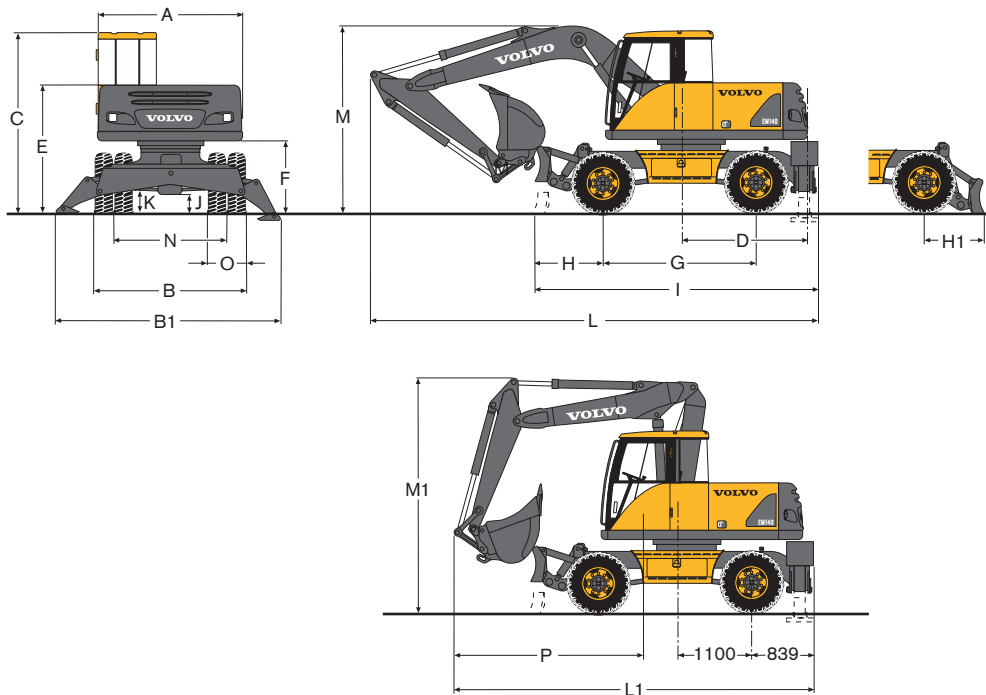

		Boom		Dipper arm	
A:	mm 2 450	L:	mm 7 436	4,5 m monobloc	2,0 m
B:	mm 2 540	L:	mm 7 160	4,5 m monobloc	2,45 m
B1:	mm 3 920	L:	mm 7 061	4,5 m monobloc	3,1 m
		L:	mm 7 043	4,5 m monobloc	3,0 m dipper arm for grab
C:	mm 3 110				
D:	mm 2 000	L1:	mm 5 956	4,7 m 2-piece	2,0 m
E:	mm 2 240	L1:	mm 6 046	4,7 m 2-piece	2,45 m
		L1:	mm 7 126	4,7 m 2-piece	3,1 m
F:	mm 1 270	L1:	mm 6 358	4,7 m 2-piece	3,0 m dipper arm for grab
G:	mm 2 600				
H:	mm 1 070	M:	mm 3 235		2,0 m
H1:	mm 1 020	M1:	mm 3 997		2,45 m
		N:	mm 1 915		
I:	mm 4 705	O:	mm 630		
J:	mm 325	P:	mm 2 910	4,7 m 2-piece	2,0 m
K:	mm 386	P:	mm 3 000	4,7 m 2-piece	2,45 m
		P:	mm 4 081	4,7 m 2-piece	3,1 m
		P:	mm 3 312	4,7 m 2-piece	3,0 m dipper arm for grab

## DIGGING RANGES

**Monobloc boom 4,5 m and  
dipper arm 2,0 m, 2,45 m, 3,1 m**

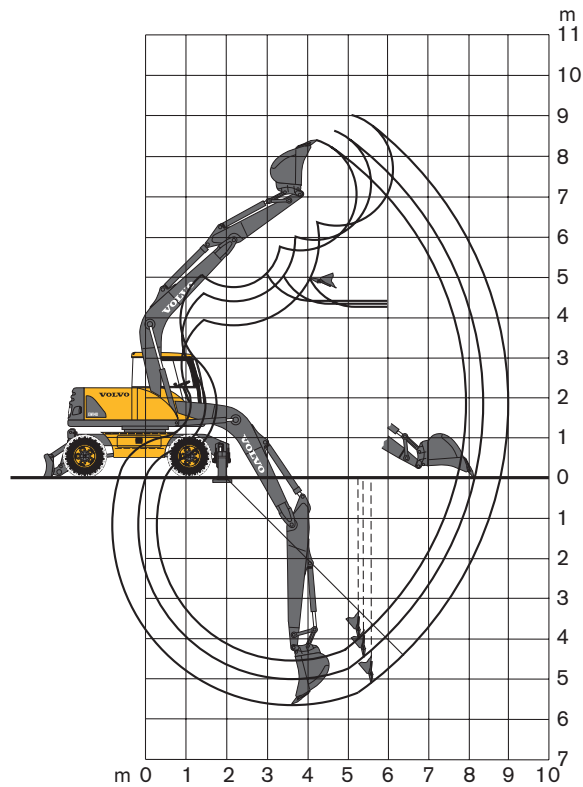

**Monobloc boom 4,5 m and  
dipper arm for grab 3,0 m**

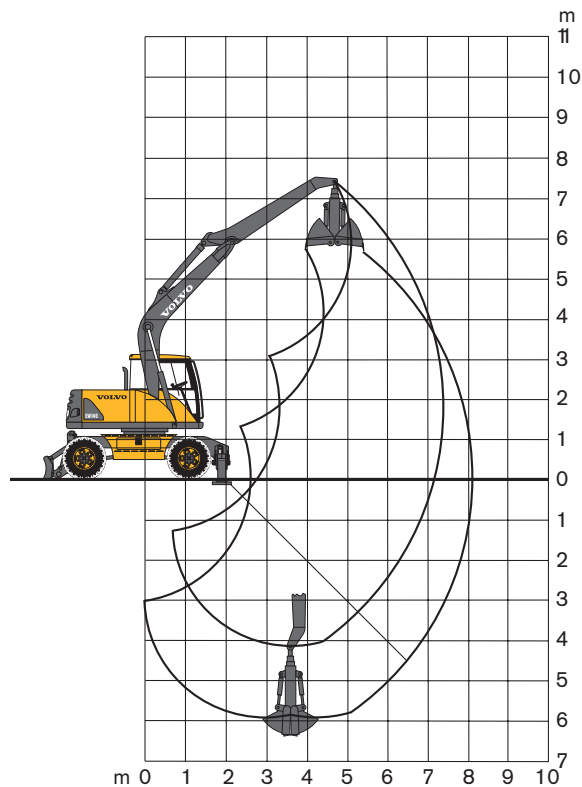

Monobloc boom	m	4,5	4,5	4,5	4,5
Dipper arm	m	2,0	2,45	3,1	3,0*
Max. reach	m	8,0	8,4	9,0	8,1
Max. reach at ground level	m	7,7	8,2	8,8	8,1
Max. digging depth	m	4,5	5,0	5,6	6,3
Max. height ground – tooth tip	m	8,4	8,6	9,0	5,7
Max. dumping height	m	5,6	5,9	6,2	5,2
Max. practical dumping height	m	4,3	4,3	4,3	5,2
Practical digging depth for a material with a 45° angle of repose	m	3,7	4,0	4,4	4,5
Max. vertical digging depth	m	3,9	4,3	5,0	6,3
Min. front slew radius	m	2,7	2,7	2,7	3,8

\* Dipper arm for grab

### Digging forces with quickfit for GP bucket:

Bucket radius	m	1,26	1,26	1,26	–
Breakout force	kN	88	88	88	–
Tearout force	kN	69	60	51	–
Rotation angle, bucket	°	185	185	185	–

### Max. permitted buckets for quickfit:

GP-bucket (1,8 t/m <sup>3</sup> )	l	760	700	600	–
-----------------------------------	---	-----	-----	-----	---

### Max. permitted buckets for pin-on:

GP-bucket (1,8 t/m <sup>3</sup> )	l	780	720	620	–
-----------------------------------	---	-----	-----	-----	---

## DIGGING RANGES

**2-piece boom 4,7 m and  
dipper arm 2,0 m, 2,45 m, 3,1 m**

**2-piece boom 4,7 m and  
dipper arm for grab 3,0 m**

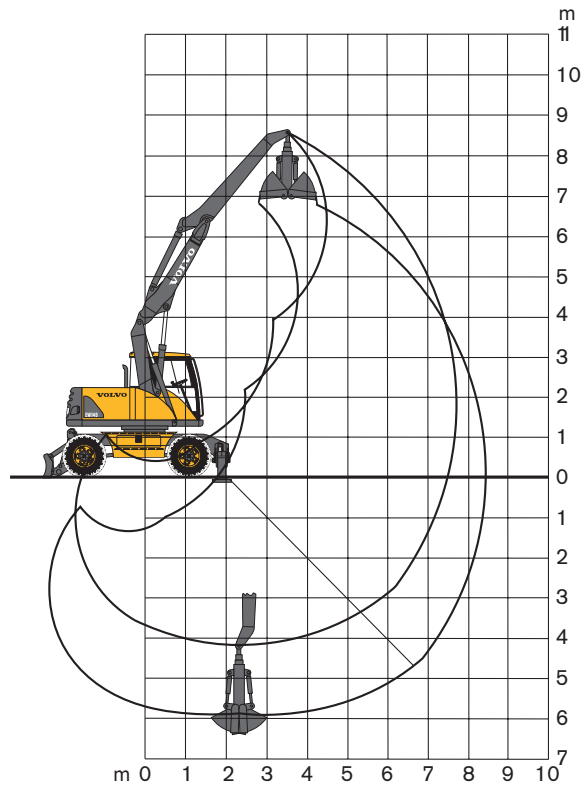
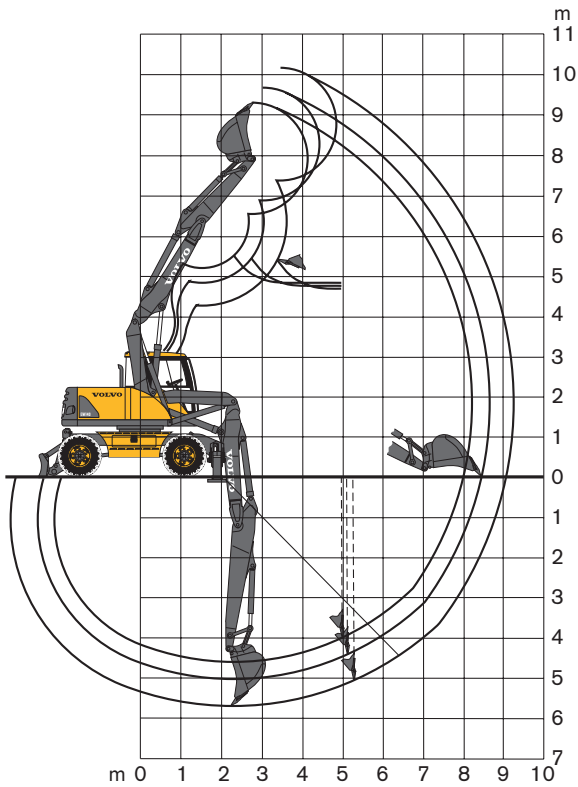

2-piece boom	m	4,7	4,7	4,7	4,7
Dipper arm	m	2,0	2,45	3,1	3,0*
Max. reach	m	8,2	8,7	9,3	8,4
Max. reach at ground level	m	8,0	8,5	9,1	8,4
Max. digging depth	m	4,6	5,0	5,7	6,3
Max. height ground – tooth tip	m	9,3	9,6	10,1	6,8
Max. dumping height	m	6,5	6,9	7,4	6,3
Max. practical dumping height	m	4,8	4,8	4,7	6,3
Practical digging depth for a material					
with a 45° angle of repose	m	3,6	4,0	4,4	4,6
Max. vertical digging depth	m	3,8	4,2	4,8	6,3
Min. front slew radius	m	2,6	2,6	2,8	3,2

\* Dipper arm for grab

### Digging forces with quickfit for GP bucket:

Bucket radius	m	1,26	1,26	1,26	–
Breakout force	kN	88	88	88	–
Tearout force	kN	69	60	51	–
Rotation angle, bucket	°	185	185	185	–

### Max. permitted buckets for quickfit:

GP-bucket (1,8 t/m <sup>3</sup> )	l	710	640	560	–
-----------------------------------	---	-----	-----	-----	---

### Max. permitted buckets for pin-on:

GP-bucket (1,8 t/m <sup>3</sup> )	l	720	660	580	–
-----------------------------------	---	-----	-----	-----	---

## DIGGING RANGES

**Offset boom 4,75 m and  
dipper arm 2,0 m, 2,45 m, 3,1 m**

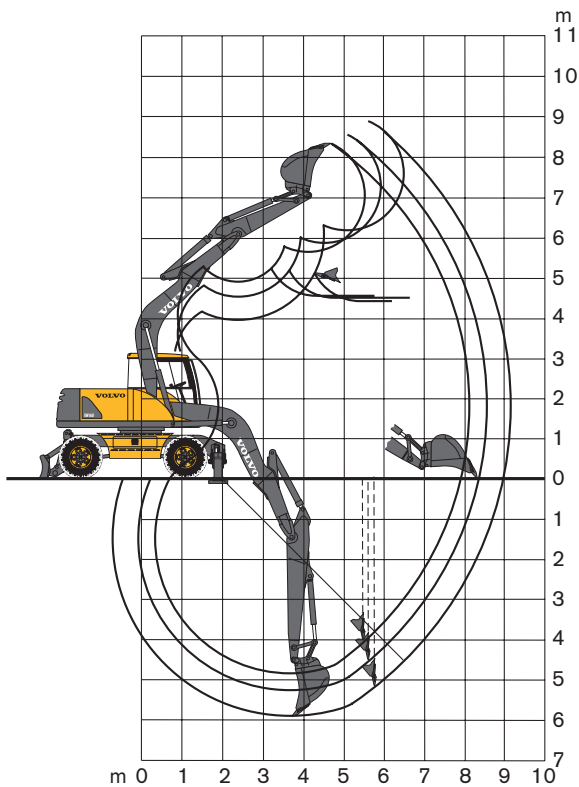

<b>Offset boom</b>	<b>m</b>	<b>4,75</b>	<b>4,75</b>	<b>4,75</b>	<b>-</b>
<b>Dipper arm</b>	<b>m</b>	<b>2,0</b>	<b>2,45</b>	<b>3,1</b>	<b>-</b>
Max. reach	m	8,1	8,6	10,0	-
Max. reach at ground level	m	7,9	8,4	9,2	-
Max. digging depth	m	4,8	5,3	5,9	-
Max. height ground – tooth tip	m	8,3	8,5	8,8	-
Max. dumping height	m	5,6	5,8	6,2	-
Max. practical dumping height	m	4,5	4,5	4,4	-
Practical digging depth for a material with a 45° angle of repose	m	3,8	4,1	4,5	-
Max. vertical digging depth	m	4,0	4,5	5,1	-
Min. front slew radius	m	2,9	2,9	3,0	-

\* Dipper arm for grab

### Digging forces with quickfit for GP bucket:

Bucket radius	m	1,26	1,26	1,26	-
Breakout force	kN	88	88	88	-
Tearout force	kN	69	60	51	-
Rotation angle, bucket	°	185	185	185	-

### Max. permitted buckets for quickfit:

GP-bucket (1,8 t/m <sup>3</sup> )	l	730	630	550	-
-----------------------------------	---	-----	-----	-----	---

### Max. permitted buckets for pin-on:



GP-bucket (1,8 t/m <sup>3</sup> )	l	750	650	570	-
-----------------------------------	---	-----	-----	-----	---







# LIFTING CAPACITY (At the quickfit lifting hook/dipper pin, without bucket. Unit: 1 000 kg.)

 Across under-carriage  Along under-carriage	Lifting hook related to ground level	Reach from machine centre												Max. m						
		3,0 m		4,5 m		6,0 m		7,5 m		Max. reach										
		u	d	u	d	u	d	u	d	u	d	u	d							
4,7 m Offset boom 2,0 m dipper arm Quickfit S6 Outriggers and Support blade rear	6,0 m																			
	4,5 m					2,9	3,8*	3,7	3,8*	1,8	3,5	2,3	3,5*			1,5	2,9	1,9	3,1*	6,6
	3,0 m					2,6	4,7*	3,3	4,7*	1,7	3,3	2,1	3,8*			1,2	2,5	1,6	3,1*	7,1
	1,5 m					2,2	4,8	3,0	5,7*	1,5	3,1	2,0	4,1*			1,1	2,4	1,5	3,3	7,2
	0,0 m					2,1	4,7	2,8	6,0*	1,4	3,0	1,9	4,3			1,1	2,5	1,5	3,5	6,9
	-1,5 m	3,9	7,8*	5,4	7,8*	2,1	4,6	2,8	5,6*	1,4	3,0	1,9	4,1*			1,3	2,9	1,8	3,9*	6,2
-3,0 m	4,1	6,1*	5,5	6,1*	2,2	4,4*	2,9	4,4*							1,9	3,9*	2,5	3,9*	5,0	
4,7 m Offset boom 2,45 m dipper arm Quickfit S6 Outriggers and Support blade rear	6,0 m									1,9	2,8*	2,4	2,8*			1,9	2,7*	2,3	2,7*	6,1
	4,5 m					3,0	3,4*	3,4*	3,4*	1,8	3,2*	2,3	3,2*			1,4	2,6*	1,8	2,6*	7,0
	3,0 m					2,7	4,3*	3,4	4,3*	1,7	3,3	2,2	3,5*	1,1	2,3	1,1	2,3	1,5	2,6*	7,5
	1,5 m					2,3	4,9	3,0	5,4*	1,5	3,1	2,0	4,0*	1,0	2,2	1,0	2,2	1,4	2,8*	7,6
	0,0 m					2,1	4,7	2,8	5,9*	1,4	3,0	1,9	4,3*			1,0	2,2	1,4	3,2	7,3
	-1,5 m	3,8	8,4*	5,2	8,4*	2,0	4,6	2,8	5,8*	1,3	3,0	1,8	4,2*			1,2	2,5	1,6	3,6	6,7
-3,0 m	4,0	6,9*	5,4	6,9*	2,1	4,7	2,8	4,9*							1,6	3,4	2,1	3,9*	5,5	
4,7 m Offset boom 3,1 m dipper arm Quickfit S6 Outriggers and Support blade rear	6,0 m									2,0	2,7*	2,5	2,7*			1,5	2,1*	1,9	2,1*	6,9
	4,5 m									1,9	2,8*	2,4	2,8*	1,2	2,4*	1,6	2,4*	1,2	2,1*	7,7
	3,0 m					2,8	3,8*	3,6	3,8*	1,8	3,2*	2,3	3,2*	1,2	2,4	1,5	2,9*	1,0	2,0	8,1
	1,5 m					2,4	4,9*	3,1	4,9*	1,6	3,2	2,1	3,7*	1,1	2,2	1,4	3,2*	0,9	1,9	8,2
	0,0 m					2,1	4,7	2,8	5,7*	1,4	3,0	1,9	4,1*	1,0	2,2	1,4	3,1	0,9	2,0	8,0
	-1,5 m	3,7	8,4*	5,1	8,4*	2,0	4,6	2,7	5,9*	1,3	2,9	1,8	4,2*			1,0	2,2	1,3	3,1	7,4
-3,0 m	3,8	7,9*	5,2	7,9*	2,0	4,6	2,7	5,4*	1,3	3,0	1,8	3,9*			1,2	2,7	1,7	3,5*	6,4	
-4,5 m					2,2	3,7*	2,9	3,7*							2,1	3,6*	2,8	3,6*	4,6	
4,7 m Offset boom 3,0 m dipper arm Outriggers and Support blade rear	6,0 m									2,0	3,0*	2,5	3,0*			1,8	2,8*	2,3*	2,8*	6,2
	4,5 m									1,9	3,1*	2,4	3,1*			1,4	2,7	1,8	2,8*	7,0
	3,0 m					2,8	4,1*	3,6	4,1*	1,8	3,4	2,3	3,5*			1,2	2,4	1,6	2,9*	7,4
	1,5 m					2,5	5,1	3,2	5,2*	1,6	3,3	2,1	4,0*	1,1	2,3	1,1	2,3	1,5	3,2*	7,5
	0,0 m	3,9	6,2*	5,3	6,2*	2,2	4,8	2,9	5,9*	1,5	3,1	2,0	4,3*			1,1	2,3	1,5	3,3	7,3
	-1,5 m	3,8	8,8*	5,2	8,8*	2,1	4,7	2,8	6,0*	1,4	3,0	1,9	4,3			1,2	2,6	1,7	3,7	6,7
-3,0 m	3,9	8,1*	5,3	8,1*	2,1	4,7	2,9	5,5*							1,6	3,3	2,1	4,1*	5,7	

Note: For lift capacity including bucket, simply subtract actual weight of bucket from the above values.

\* Load capacity limited by machine's hydraulic lifting capacity.

The above values have been calculated in compliance with ISO standard 10 567. They do not exceed 87 % of hydraulic lifting capacity or 75 % of tipping load, with the machine on firm, level ground.

Working pressure with Power Boost = 35 MPa (350 bar/5 221psi)

## STANDARD EQUIPMENT

### Engine and electrical system

Contronic – computerized monitoring and alarm system  
 Battery disconnecter  
 Electrical engine rpm control  
 Electronically controlled pump regulation (SSC)  
 3-stage air filter with indicator  
 Hour meter  
 Tachometer  
 Fuel level gauge  
 Electric preheating coil  
 24 V electrical system  
 Well-protected electrical system based on printed circuit board  
 Water separating fuel filter  
 2 working lights on the cab

### Undercarriage

4-wheel drive  
 Oscillating front axle  $\pm 9^\circ$   
 Axles with hub reduction  
 2-circuit travel brakes

### Superstructure

Counterweight 2 400 kg

### Safety and comfort

Safety bar to prevent accidental actuation via levers and pedals  
 Interior lighting in cab  
 2 exterior rear-view mirrors  
 Ergonomic, operator's seat with seat belt  
 Cab heating  
 Filtered air intake  
 Skylight of special plastic  
 Sliding side window in cab door  
 Interior sun visor  
 Tinted window glass  
 Upper windscreen wiper with intermittent function  
 Windscreen washer  
 Horn  
 Glasscrusher hammer  
 Oil draining cock on the engine  
 Slew holding brake automatics

### Hydraulic system

Variable axial-piston pump  
 Mode Selector with 3 different modes  
 Power Boost  
 Wrist type control levers with four switches each  
 Hydraulic cylinders with internal end dampening  
 Variable motor with pressure control  
 Return filter of full flow type 1000 h exchange interval  
 Pressure relief system (Servo accumulator)  
 Hydraulically driven, thermostatically controlled cooling fan

### Digging equipment

Attachment points for extra hydraulics

### Environment

Sound pressure level ( $L_{pA}$ ): **73 dB(A)**  
 Sound power level ( $L_{WA}$ ): **99 dB(A)**  
 Approved acc. EEC guidelines:  
 84/532 EEC  
 79/113 EEC  
 86/662 EEC  
 German environmental certification «**low noise**»  
 RAL-UZ53

## ALTERNATIVE EQUIPMENT

### Undercarriage

Twin wheels 10.00–20  
 Single wheels 18R-19,5  
 Dozer blade in front, and two outriggers rear  
 Grab bucket holder  
 Support blade, rear  
 4 outriggers

### Digging equipment

#### Booms

4,5 m monobloc  
 4,7 m 2-piece boom  
 4,7 m offset boom

#### Dipper arms

2,0 m  
 2,45 m  
 3,1 m  
 3,0 m dipper arm for grab

### Buckets

#### General Purpose bucket (GP)

Capacity	Width
190 l	400 mm
260 l	500 mm
340 l	600 mm
420 l	700 mm
500 l	800 mm
580 l	900 mm
670 l	1 000 mm
750 l	1 100 mm

### Hydraulic quickfit

S6  
 Safety lifting hook on quickfit

## OPTIONAL EQUIPMENT (Standard on certain markets)

### Engine and electrical system

Diesel-powered cab and engine heater with digital timer  
 Auto idling  
 Electric engine heater (220 V)  
 Extra headlights on boom  
 Working lights (halogen):  
 1 rear  
 Protective net in front of the cooler  
 Alternator 80 A  
 Coolant filter  
 Extra fuel filter

### Undercarriage

Stone protection rings  
 Mud guards  
 Tool box  
 Rear axle with limited slip  
 Rear axle with drum brake  
 Rear axle with limited slip and drum brake

### Safety and comfort

Protective net for windscreen  
 Protective cab roof (FOGS ISO 10 262-approved)  
 Hose rupture valve on boom cylinder incl. overload alarm

Extra hose rupture valve – dipper arm cylinder  
 Rotating warning beacon  
 Electrically powered fuelling pump, 30 l/min, with overfilling protection  
 Ergonomic, electrically heated operator's seat with seat belt  
 Ergonomic, electrically heated operator's seat with air suspension and seat belt  
 Sun visor, rear window and skylight  
 Lower windscreen wiper with intermittent function  
 Air conditioning  
 Radio with tape player

Tool kit  
 Travel alarm  
 Cruise controller

### Hydraulic system

Float position on boom  
 Biodegradable hydraulic oil  
 Hydraulic equipment for:  
 A. Slope bucket/rotator  
 B. Hammer/shears/grab/clam shell  
 C. Quickfit

Under our policy of continuous product improvement, we reserve the right to change specifications and design without prior notice. The illustrations do not necessarily show the standard version of the machine.

# VOLVO

Volvo Construction  
 Equipment

Ref. No. 21 3 433 1168 English global  
 Printed in Germany 2001.03 EXC  
 Volvo, Konz 14372501