

Åkerman EW230B



- **Engine Power:**
122 kW (166 hp)
- **Operating Weight:**
20,0 t
- **Buckets:**
345 – 1175 l
- *Direct injection, turbocharged Volvo diesel engine*
 - *Åkerman three-circuit multilevel priority hydraulic system*
 - *COS = Capacity Optimized System – all three pumps for the digging movements. Mode Selector and electronically controlled pump regulation SSC. (Speed Sensing Control)*
- *Comfort cab*
 - *computerized control and warning system*
 - *ergonomic environment*
 - *low sound level*
 - *filtered air*
- *Digging and breakout forces for tough conditions*
- *Highest flexibility for extra equipment/hydraulics*
- *Four travel speeds – max. 30 km/h*
- *Individually operated outriggers and dozer blade*
- *Heavy duty equipment with spherical bearings*

ÅKERMAN

ENGINE



The engine is a turbocharged, 4-stroke diesel engine with water cooling and direct injection.

Make		Volvo
Model		TD 61 GE
Net output at	r/s (r/min)	35 (2100)
ISO 3046 / DIN 6271*	kW (hp)	122 (166)
No. of cylinders		6
Displacement, total	l	5,48
Bore	mm	98,43
Stroke	mm	120

* Excl. fan

ELECTRIC SYSTEM



Micro processor for monitoring of engine/hydraulic system. High capacity and well protected electric system. Printed circuit board based electric central with clearly arranged fuses and relays. Battery disconnecter standard.

Voltage	V	24
A.C. Generator	V/A	28/55
Battery	V	4 x 12
Battery capacity	Ah	120
Alternator rating	W	1540

SLEWING SYSTEM



The superstructure is slewed by an axial piston motor through a servo released slew brake, into the two-step slew gear giving torque to the inner tooth race of the slew ring. The entire slew ring runs in a dust protected oil bath.

Slew, start to stop*		
90° turn	s	6,2
180° turn	s	8,2

* Empty bucket and extended equipment.

BRAKES



Brake system corresponds to ISO 3450.

Service brakes consist of a 2-circuit oil servo system with drum brakes on each axle.

Parking brake of drum type mounted on the gearbox. It is activated by spring power and servo released.

Digging brake without play is obtained through the same drum brake system.

Security system: The 2-circuit travel brakes are supplied with two accumulators in the event of failure in the service brake system.

UNDERCARRIAGE



Drive Train: One big variable piston motor on the mid-mounted two-step gearbox gives power to front and rear axles, both with hub reductions.

Framework and supports: All-welded robust torsion box frame with two outriggers on rear end and a dozer blade on the front end. These 3 supports can by choice be operated separately or simultaneously for quick re-positioning.

Wheels: Alternative single and twin wheels available.

Front axle: Oscillating 8°.

Twin wheels, standard		10.00 - 20 PR16
Max tractive force	kN	148
Travel speed, road travel	km/h	0 - 30
Travel speed, site travel	km/h	0 - 8
Turning radius, front wheels	m	8,0

CAB



Operator's cab with a supporting frame structure. Large panes for all round good visibility. The upper front pane can be pushed up in the ceiling, and the lower one can be removed. Sliding window in the cab door.

Heater and defroster: Pressurized and filtered cab. A 3-speed fan provides efficient heating and defrosting through 14 outlets. Prepared for Air Conditioning.

Operator's seat: Adjustable suspension operator's seat with heating coils, headrest and individually adjustable armrests and hand controls.

Sound level: Approved according to 86/662/EEC.

Surroundings (ISO 6393)		
L_{WA} (acoustic power)	dB(A)	108
Inside the cab (ISO 6394)		
with the door closed		
L_{pA} (acoustic pressure)	dB(A)	76

SERVICE REFILL CAPACITIES



Fuel tank	l	340
Fuel pump capacity	l/min	90
Hydraulic system, total	l	400
Diesel engine	l	22
Cooling system (incl. glycol)	l	32
Slew ring	l	35
Travel gearbox	l	5

HYDRAULIC SYSTEM



Åkerman 3-circuit multilevel priority system all-servo controlled.

Pumps: P1 is a pressure controlled variable pump with priority to slew circuit. P2 and P3 are power and pressure controlled variable pumps with opposite cross flow priority to boom, bucket and arm.

Mode selector: Three working modes:

HLD = Heavy Lift Device

ECO = Economy

CAP = Capacity.

Powerboost temporarily selectable for up to 10 sec. in Economy and Capacity mode. Electronically controlled pump regulation for highest power output.

Valve system: Boom, arm and bucket are operated by dual main valves to obtain best combination of precision manoeuvrability and minimized fuel consumption. Boom cylinder equipped with floating position valve for improved comfort and increased digging speed. Security hose rupture valve on the boom cylinder.

Pump P1			
Max. pressure	MPa	26	
Max. flow	l/min	88	
Pumps P2 and P3			
Max. pressure	MPa	28	
Power boost	MPa	32	
Max. flow	l/min	2 x 142	
Servo pump			
Pressure	MPa	6,5	
Flow	l/min	28	
Steering pump			
Pressure	MPa	14	
Flow	l/min	34	

DIMENSIONS

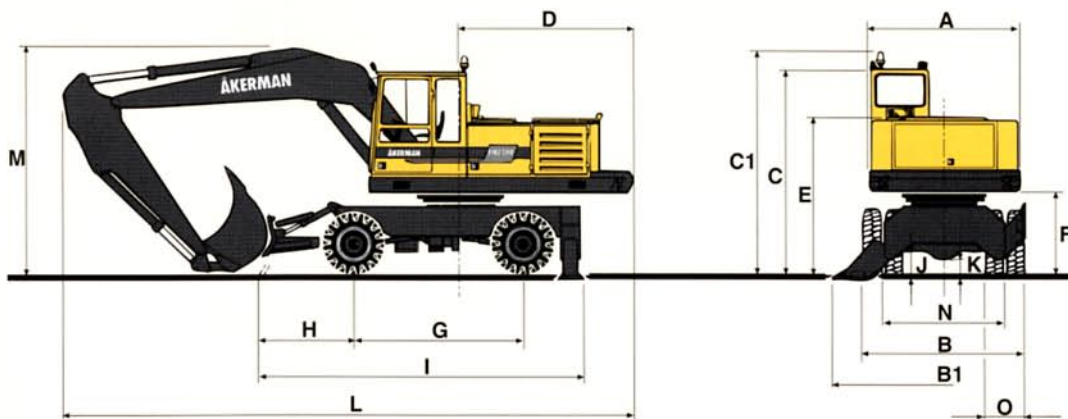

A:	mm	2490		J:	mm	400	
B:	mm	2470	(2580 mm with widening rings)	K:	mm	330	
B1:	mm	3330	(3350 mm with articulated plate)	L:	mm	9200	(2,25 m arm)
C:	mm	3260		L:	mm	9100	(2,80 m arm)
C1:	mm	3530		L:	mm	9000	(3,30 m arm)
D:	mm	2870		M:	mm	3900	(2,25 m arm)
E:	mm	2460		M:	mm	4200	(2,80 m arm)
F:	mm	1270		M:	mm	4500	(3,30 m arm)
G:	mm	2780		N:	mm	1900	
H:	mm	1170		O:	mm	600	
I:	mm	4990					

WORKING RANGES

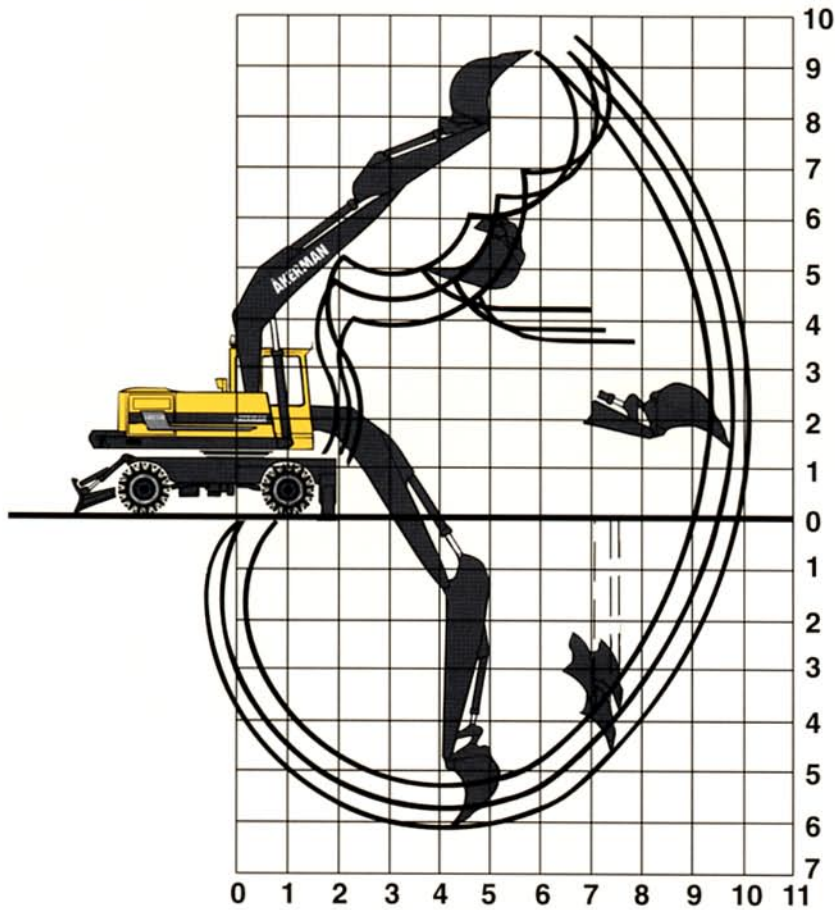

Boom	m	5,2	5,2	5,2
Arm	m	2,25	2,80	3,30
Max reach	m	9,4	9,8	10,2
Max. reach at ground level	m	9,1	9,5	9,9
Max. digging depth	m	5,4	5,8	6,2
Max. height, ground – tooth tip	m	9,2	9,2	9,5
Max. dumping height	m	6,1	6,3	6,8
Max. practical dumping height	m	4,0	3,8	3,7
Practical digging depth at a repose of material of 45°	m	4,5	4,8	5,1
Max. vertical digging depth	m	3,9	3,9	4,6
Min. slewing radius in front	m	4,1	4,1	4,2

BUCKET AND ARM COMBINATIONS

BUCKETS	Volume SAE l	Cutting width mm (ins)	Weight kg	Fitting *	Suitable for arm		
					2,25 m	2,80 m	3,30 m
Rock 2 t/m ³	900	1050(41)	760	QF	•	•	
	900	1050(41)	760	D	•	•	
Heavy Duty 2 t/m ³	1000	1200(48)	810	QF	•	•	
Bulk 1,5 t/m ³	1200	1500(60)	900	QF	•	•	
G.P./Trench slope bucket	345	500(20)	510	QF	•	•	•
	443	600(24)	550	QF	•	•	•
	768	900(36)	720	QF	•	•	•
	1093	1200(48)	860	QF	•	•	•
Ditch cleaning	970	1500(60)	570	QF	•	•	•
	1175	1800(72)	650	QF	•	•	•

DIGGING FORCE

Bucket digging force*	kN	177
Dipper arm force*	kN	125

* Std. HD-bucket, 900 l SAE and 2,25 m dipper arm.

D = Direct fitting

QF = Quickfit

WEIGHT AND AXLE LOAD















Machine with 5,2 m boom, 2,8 m dipper arm, quickfit,
1 000 l bucket and 3 000 kg counterweight.

Total machine weight (incl. dozer blade)	kg	20 000
Axle load (incl. dozer blade)		
Front axle	kg	9 200
Rear axle	kg	10 800

LIFTING CAPACITIES

Max load at dipper pin. Unit: 1 000 kg.

 Across carriage  Along carriage	Lifting hook related to ground level	Reach from machine centre										
		4,5 m		6,0 m		7,5 m		9,0 m		Max. reach		Max. m
												
5,20 m boom 2,25 m arm Outriggers and dozerblade down	7,5 m											
	6,0 m			4,62	5,54 *					4,03	5,41 *	6,5
	4,5 m	6,66 *	6,66 *	4,42	5,81 *					3,33	4,59	7,2
	3,0 m	6,31	8,37 *	4,18	5,83	3,03	4,20			2,97	4,12	7,6
	1,5 m	5,95	8,66	3,98	5,61	2,94	4,11			2,89	4,03	7,6
	0,0 m	5,80	8,50	3,87	5,49					3,01	4,21	7,3
	-1,5 m	5,79	8,48	3,87	5,48					3,39	4,76	6,7
-3,0 m	5,92	8,34 *							4,42	6,17 *	5,6	
5,20 m boom 2,80 m arm Outriggers and dozerblade down	6,0 m			4,66	4,85 *					3,47 *	3,47 *	7,1
	4,5 m			4,45	5,25 *	3,11	4,30			2,97	3,94 *	7,7
	3,0 m	6,41	7,59 *	4,19	5,85	3,00	4,17			2,71	3,78	8,0
	1,5 m	5,94	8,66	3,95	5,59	2,88	4,04			2,58	3,63	8,1
	0,0 m	5,71	8,41	3,80	5,42	2,81	3,97			2,68	3,77	7,8
	-1,5 m	5,65	8,34	3,75	5,37					2,97	4,20	7,2
	-3,0 m	5,74	8,43	3,85	5,48					3,70	5,25	6,2
5,20 m boom 3,30 m arm Outriggers and dozerblade down	6,0 m					3,20	4,40			3,12	3,99 *	7,6
	4,5 m			4,51	4,78 *	3,13	4,32			2,61	3,31 *	8,3
	3,0 m	6,57	6,90 *	4,24	5,59 *	3,00	4,18			2,40	3,36	8,6
	1,5 m	6,04	8,70 *	3,98	5,62	2,87	4,03			2,34	3,29	8,6
	0,0 m	5,73	8,44	3,79	5,42	2,77	3,93			2,41	3,41	8,3
	-1,5 m	5,61	8,32	3,71	5,33	2,75	3,90			2,62	3,71	7,8
	-3,0 m	5,65	8,36	3,74	5,37					3,14	4,45	6,9
	-4,5 m	5,87	7,26 *							4,68	5,67 *	5,3

* Limited by hydraulic lifting capacity.
The above loads are in compliance with ISO standard 10567. They do not exceed 87% of hydraulic lifting capacity or 75 % of tipping load, with the machine on firm, level ground.
 Working pressure with HLD = 32 MPa (320 bar)

STANDARD EQUIPMENT

Engine and Electrical System

Computer controlled monitoring system
 Battery disconnecter and main fuel tap
 Automatic idling speed (Fuel-miser)
 Air filter with indicator
 Hour meter
 Electric preheating element
 Revs counter
 Fuel meter
 Temperature meter for cooling fluid and hydraulic oil
 24 volt electrical system with 4 standard batteries
 Cranked exhaust pipe

Undercarriage

Slew ring in oil bath
 Twin wheels 10.00 – 20 PR16
 4-wheel drive
 Dozer blade in front and two outriggers rear
 Oscillating front axle $\pm 8^\circ$
 Axles with hub reduction
 2-circuit travel brakes

Superstructure

Counterweight 3000 kg

Safety and Comfort

Safety bar for control levers
 Hose rupture valve on boom cyl.
 Hydraulic refuelling pump, 90 l/min
 Over load indicator
 Lights:
 headlights, full and dipped beam
 asymmetrical, halogen
 Brakelights
 Rear lights
 Direction indicators
 Rotating beacon
 Hazard flashers
 3 working lights, front, halogen
 1 working light, rear, halogen
 Instrument lighting
 Illuminated cab, engine compartment and fuel filling compartment
 Rear view mirrors:
 4 exterior, 1 interior
 Cab heating with 14 outlets
 Ergonomically designed and adjustable operator's seat, with heating coils
 Adjustable steering wheel
 Filtered air intake
 Cab skylight

Sliding window in the cab door
 Emergency exit through rear window
 Tinted windows (clear front)
 Internal sunvisor
 Double intermittent windscreen wipers
 Windscreen washers
 Compressor horn
 Radio cassette player

Hydraulics

Float position on boom
 Three variable axial piston working pumps
 Mode selector, 3 steps
 Power boost
 Dual main valve for the travel and equipment functions
 Standard filter cartridges for return, leak oil and respiration filter systems
 Swing-out oil cooler
 Hydraulic equipment for quickfit
 Hammer hydraulics

Equipment

5,2 m monobloc boom
 2,8 m dipper arm
 Hydraulic quickfit
 End dampening on all cylinders
 Spherical link bearings in all connections
 Security lifting hook
 Friction welded piston rod eyes

OPTIONAL EQUIPMENT *(Standard on certain markets)*

Engine and Electrical System

Electric over speed protector
 Volvo diesel driven engine and cab heater, with digital timer
 Immersion heater, 220 V
 Precyclone with exhaust ejector

Undercarriage

Twin wheels
 11.00 – 20 PR16
 12.00 – 20 PR16
 Single tyres
 Solid tyres
 Mud guards
 Stone protection rings
 Widening rings 2 x 50 mm
 Oscillating outriggers plates
 Tool box
 Tow hook

Safety and Comfort

Protective grid for front pane/roof pane
 Fire extinguisher
 Seat belts
 Protection against overfilling fuel
 Extra circulation pump for the heating system
 Extra hose rupture valve on dipper arm/bucket cylinders
 Exterior glare shields
 Rear window jalousie
 Air conditioning
 Micro filter for the cab
 Cruise controller

Hydraulics

Biologically degradable oil
 Hydraulic equipment for:
 slope bucket
 grab
 roto-tilt
 jib
 crusher
 shears
 magnet
 Installation of a 4th working pump

Equipment

2,25 m and 3,3 m dipper arm
 Extra headlights on the boom

Under our policy of continuous product improvement, we reserve the right to change specifications and design without prior notice. The illustrations do not necessarily show the standard version of the machine.

Volvo Construction Equipment

Ref. No. 23 2 430 0060 BRITISH
 Printed in Sweden 02.05.95 EXC