

# Åkerman EW200



- **Engine Power:**  
107 kW (145 hp)
- **Operating Weight:**  
16,9 – 18,0 t
- **Buckets:**  
306 – 1010 l
- *Direct injection, turbocharged Volvo diesel engine*
- *Åkerman three-circuit multilevel priority hydraulic system*
- *COS = Capacity Optimized System – all three pumps for the digging movements. Mode Selector with pump regulation PCS. (Pressure Sensing Control)*
- *Comfort cab*
  - computerized control and warning system
  - ergonomic environment
  - low sound level
  - filtered air
- *Digging and breakout forces for tough conditions*
- *Highest flexibility for extra equipment/hydraulics*
- *Four travel speeds – max. 30 km/h*
- *Individually operated outriggers and dozer blade*

**ÅKERMAN**

## ENGINE



The engine is a turbocharged, 4-stroke diesel engine with water cooling and direct injection.

Make		Volvo
Model		TD 61 GE
Net output at	r/s (r/min)	30 (1800)
ISO 3046 / DIN 6271*	kW (hp)	107 (145)
No. of cylinders		6
Displacement, total	l	5,48
Bore	mm	98,43
Stroke	mm	120

\* Fan excluded

## ELECTRIC SYSTEM



Micro processor for monitoring of engine/hydraulic system. High capacity and well protected electric system. Printed circuit board based electric central with clearly arranged fuses and relays. Battery disconnecter standard.

Voltage	V	24
A.C. Generator	V/A	28/55
Battery	V	4 x 12
Battery capacity	Ah	120
Alternator rating	W	1540

## SLEWING SYSTEM



The superstructure is slewed by an axial piston motor through a servo released slew brake, into the two-step slew gear giving torque to the inner tooth race of the slew ring.

Slew, start to stop*		
90° turn	s	5,0
180° turn	s	7,0

\* Empty bucket and extended equipment.

## BRAKES



Brake system corresponds to ISO 3450.

**Service brakes** consist of a 2-circuit oil servo system with drum brakes on each axle.

**Parking brake** of drum type mounted on the gearbox. It is activated by spring power and servo released.

**Digging brake** is obtained through the same drum brake system.

**Security system:** The 2-circuit travel brakes are supplied by two accumulators in the event of failure in the service brake system.

## UNDERCARRIAGE



**Drive Train:** One big variable piston motor on the mid-mounted two-step gearbox gives power to front and rear axles, both with hub reductions.

**Framework and supports:** All-welded robust torsion box frame with two outriggers on rear end and a dozer blade on the front end. These 3 supports can by choice be operated separately or simultaneously for quick re-positioning.

**Wheels:** Alternative single and twin wheels available.

**Front axle:** Oscillating  $\pm 7^\circ$ .

Twin wheels, standard		10.00 - 20 PR14
Max tractive force	kN	114
Travel speed, road travel	km/h	0 - 30
Travel speed, site travel	km/h	0 - 7
Turning radius, front wheels	m	8,0

## CAB



Operator's cab with a supporting frame structure. Large panes for all round good visibility. The upper front pane can be pushed up in the ceiling, and the lower one can be removed. Sliding window in the cab door.

**Heater and defroster:** Pressurized and filtered cab. A 3-speed fan provides efficient heating and defrosting through 14 outlets. Prepared for Air Conditioning (optional).

**Operator's seat:** Adjustable suspension operator's seat with heating coils, headrest and individually adjustable armrests and hand controls.

**Sound level:** Approved according to 86/662/EEC.

Surroundings (ISO 6393)		
$L_{WA}$ (acoustic power)	dB(A)	aprox. 104
Inside the cab (ISO 6394)		
with the door closed		
$L_{pA}$ (acoustic pressure)	dB(A)	aprox. 74

## SERVICE REFILL CAPACITIES



Fuel tank	l	290
Fuel pump capacity	l/min	90
Hydraulic system, total	l	320
Diesel engine	l	22
Cooling system (incl. glycol)	l	32
Travel gearbox	l	4,0
Slew gearbox	l	16,0

## HYDRAULIC SYSTEM



**Åkerman 3-circuit multilevel priority system all-servo controlled.**

**Pumps:** P1 is a pressure controlled variable pump with priority to slew circuit. P2 and P3 are power and pressure controlled variable pumps with opposite cross flow priority to boom, bucket and arm.

**Mode selector:** Three working modes:

**HLD** = Heavy Lift Device

**ECO** = Economy

**CAP** = Capacity

Powerboost temporarily selectable in 10 sec. even in Economy and Capacity mode.

**Valve system:** Boom, arm and bucket are operated by dual main valves to obtain best combination of precision manoeuvrability and minimized fuel consumption. Boom cylinder equipped with floating position valve for improved comfort and increased digging speed. Security hose rupture valve on the boom and dipper cylinders.

Pump P1			
Max. pressure	MPa		28
Max. flow	l/min		64
Pumps P2 and P3			
Max. pressure	MPa		26
Power boost	MPa		30
Max. flow	l/min		2 x 114
Servo pump			
Pressure	MPa		6,5
Flow	l/min		24
Steering pump			
Pressure	MPa		14
Flow	l/min		29

## DIMENSIONS

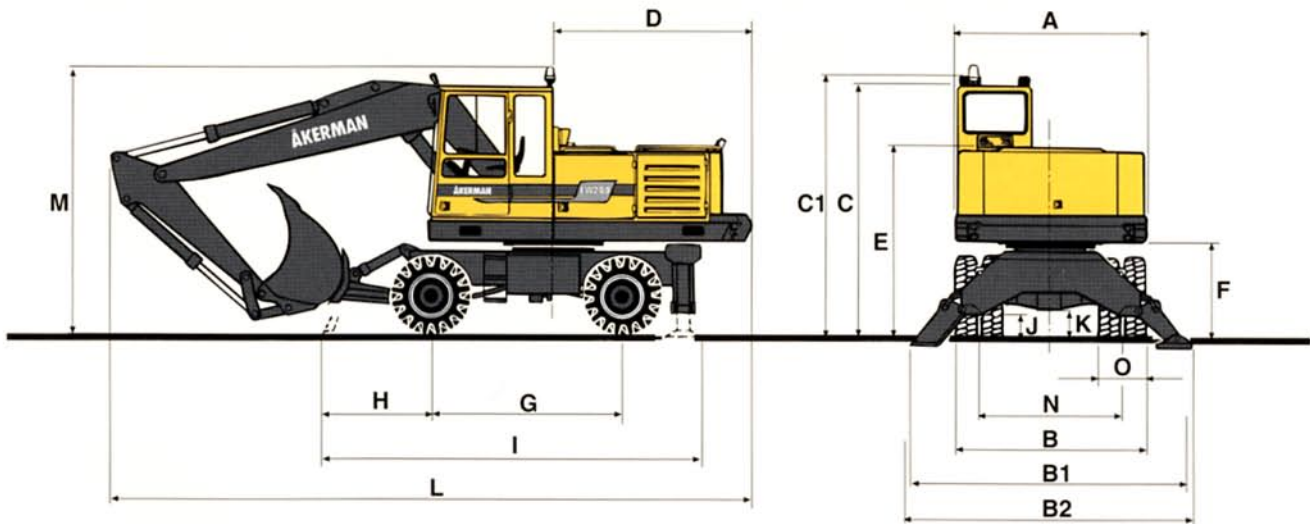

A:	mm	2490		
B:	mm	2500		
B1:	mm	3690		
B2:	mm	3750		
C:	mm	3220		
C1:	mm	3360		
D:	mm	2600		
E:	mm	2410		
F:	mm	1180		
G:	mm	2500		
H:	mm	1240		
I:	mm	4750		
J:	mm	330		
K:	mm	360		
L:	mm	8300		(2,0 m arm and 4,65 m boom)
L:	mm	8200		(2,4 m arm and 4,65 m boom)
L:	mm	8000		(2,8 m arm and 4,65 m boom)
M:	mm	3500		(2,0 m arm and 4,65 m boom)
M:	mm	3600		(2,4 m arm and 4,65 m boom)
M:	mm	3800		(2,8 m arm and 4,65 m boom)
N:	mm	1910		
O:	mm	590		

## WORKING RANGES

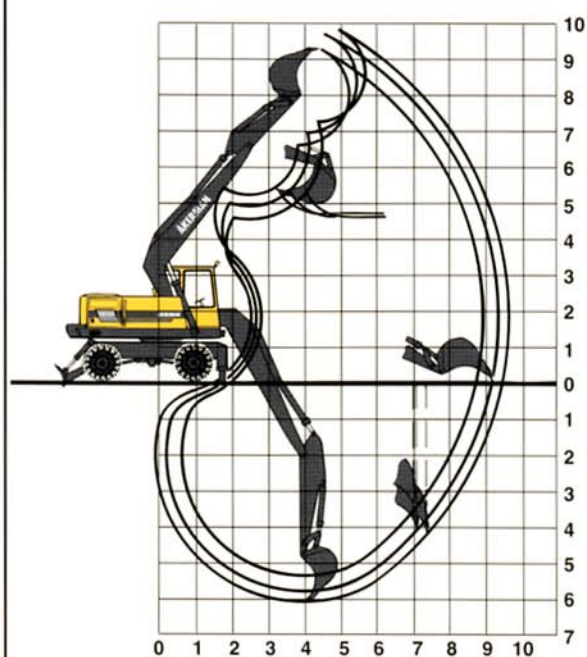

Arm	m	boom 4,65 m			boom 5,2 m		
		2,0	2,4	2,8	2,0	2,4	2,8
Max. reach	m	8,5	8,9	9,2	9,1	9,4	9,7
Max. reach at ground level	m	8,3	8,7	9,0	8,9	9,2	9,5
Max. digging depth	m	5,0	5,4	5,7	5,6	5,8	6,1
Max. height, ground – tooth tip	m	9,1	9,5	9,7	9,4	9,7	9,9
Max. dumping height	m	6,2	6,6	6,9	6,5	6,9	7,3
Max. practical dumping height	m	4,2	4,1	4,2	4,6	4,6	4,6
Practical digging depth at a repose of material of 45°	m	4,1	4,4	4,6	4,5	4,7	4,9
Max. vertical digging depth	m	3,6	4,1	4,2	3,8	4,2	4,3
Min. slewing radius in front	m	3,1	3,3	3,4	3,3	3,5	3,5

## DIGGING FORCE

Bucket digging force*	kN	126
Dipper arm force*	kN	94

\* HD-bucket, 725 l SAE and 2,0 m dipper arm.

## BUCKET AND ARM COMBINATIONS

BUCKETS	Volume SAE l	Cutting width mm (ins)	Weight kg	Fitting *	Suitable for					
					boom 4,65 m and arm			boom 5,2 m and arm		
					2,0 m	2,4 m	2,8 m	2,0 m	2,4 m	2,8 m
Rock 2 t/m <sup>3</sup>	900	1125 (44)	585	QF	•	•	•	•	•	•
Heavy duty 2 t/m <sup>3</sup>	895	1200 (48)	750	QF	•	•	•	•	•	•
	895	1200 (48)	740	D	•	•	•	•	•	•
Bulk 1,5 t/m <sup>3</sup>	1130	1500 (60)	810	QF	•	•	•	•	•	
G.P. Trench 1,6 t/m <sup>3</sup>	306	500 (20)	400	QF	•	•	•	•	•	•
	395	600 (24)	440	QF	•	•	•	•	•	•
	606	750 (34)	520	QF	•	•	•	•	•	•
	768	900 (36)	580	QF	•	•	•	•	•	•
Ditch cleaning	970	1500 (60)	570	QF	•	•	•	•	•	•
	1175	1800 (72)	680	QF	•	•	•	•	•	•

\* D = Direct fitting

QF = Quickfit

## WEIGHT AND AXLE LOAD



Standard machine, 4,65 m boom, 2,8 m dipper arm, 900 l bucket and counterweight 2200 kg.













Machine with 5,2 m boom, 2,4 m dipper arm, quickfit, 950 l bucket and 2600 kg counterweight.

Total machine weight (incl. dozer blade)	kg	16 950
Axle load		
Front axle	kg	7 750
Rear axle	kg	9 200

Total machine weight (incl. dozer blade)	kg	17 500
Axle load		
Front axle	kg	7 700
Rear axle	kg	9 800

## LIFTING CAPACITIES

Max. load at dipper pin. Unit: 1000 kg.

 Across carriage  Along carriage	Lifting hook related to ground level	Reach from machine centre										
		3,0 m		4,5 m		6,0 m		7,5 m		Max. reach		Max. m
												
<b>4,65 m boom</b> <b>2,8 m arm</b> <b>Outriggers and dozer blade down</b> <b>2 600 kg Counterweight</b>	6,0 m					3,84 *	3,84 *			3,09 *	3,09 *	6,5
	4,5 m			4,18 *	4,18 *	3,94 *	3,94 *			2,64 *	2,64 *	7,3
	3,0 m			5,36 *	5,36 *	4,41 *	4,41 *	3,20	3,84 *	2,45 *	2,45 *	7,7
	1,5 m			6,59 *	6,59 *	4,35	4,95 *	3,13	4,13 *	3,02	3,17 *	7,7
	0,0 m	6,26 *	6,26 *	6,51	7,26 *	4,23	5,28 *	2,98 *	2,98 *	2,98 *	2,98 *	7,5
	-1,5 m	10,4 *	10,4 *	6,43	7,15 *	4,18	5,14 *			3,47	3,58 *	6,9
	-3,0 m	8,93 *	8,93 *	6,06 *	6,06 *					3,80 *	3,80 *	5,9
<b>5,2 m boom</b> <b>2,8 m arm</b> <b>Outriggers and dozer blade down</b> <b>2 600 kg Counterweight</b>	7,5 m					3,53 *	3,53 *			3,53 *	3,53 *	6,0
	6,0 m					3,34 *	3,34 *			3,51 *	3,51 *	7,1
	4,5 m			4,05 *	4,05 *	3,63 *	3,63 *	3,24	3,48 *	3,03	3,40 *	7,8
	3,0 m			5,32 *	5,32 *	4,17 *	4,17 *	3,16	3,65 *	2,74	3,15 *	8,2
	1,5 m			6,51 *	6,51 *	4,25	4,74 *	3,07	3,90 *	2,64	2,92 *	8,3
	0,0 m			6,31	7,08 *	4,11	5,10 *	3,00	4,03 *	2,74	3,71	8,0
	-1,5 m	6,95 *	6,95 *	6,24	7,00 *	4,05	5,10 *	2,99	3,77 *	2,99	3,77 *	7,5
-3,0 m	9,05 *	9,05 *	6,26 *	6,26 *	4,09	4,47 *			3,69	3,85 *	6,5	
-4,5 m			4,20 *	4,20 *					3,74 *	3,74 *	4,8	
<b>5,1 m 2-piece boom</b> <b>2,4 m arm</b> <b>Outriggers and dozer blade down</b> <b>2 600 kg Counterweight</b>	7,5 m			5,24 *	5,24 *					5,11 *	5,11 *	5,3
	6,0 m			5,13 *	5,13 *	4,53 *	4,53 *			3,96	4,45 *	6,6
	4,5 m			5,70 *	5,70 *	4,57	4,65 *			3,23	4,08 *	7,4
	3,0 m			6,57 *	6,57 *	4,37	4,95 *	3,11	4,06 *	2,92	3,72 *	7,8
	1,5 m			6,44	7,11 *	4,19	5,16 *	3,04	4,01 *	2,88	3,77 *	7,8
	0,0 m			6,27	6,88 *	4,08	5,03 *	3,01	3,62 *	2,96	3,46 *	7,6
	-1,5 m			5,89 *	5,89 *	4,07	4,32 *			3,07 *	3,07 *	7,0
-3,0 m												

\* Limited by hydraulic lifting capacity.

**The above loads are in compliance with ISO standard 10567. They do not exceed 87% of hydraulic lifting capacity or 75 % of tipping load, with the machine on firm, level ground.**

Working pressure with HLD = 30 MPa (300 bar)

## STANDARD EQUIPMENT

### Engine and Electrical System

Computer controlled monitoring system  
 Battery disconnecter and main fuel tap  
 Automatic idling speed (Fuel-miser)  
 Air filter with indicator  
 Hour meter  
 Revs counter  
 Fuel meter  
 Temperature meter for cooling fluid and hydraulic oil  
 Electric preheating element  
 24 volt electrical system with 4 standard batteries  
 Cranked exhaust pipe

### Undercarriage

Twin wheels 10.00 – 20 PR14  
 4-wheel drive  
 Dozer blade in front, and two outriggers rear  
 Oscillating front axle  $\pm 7^\circ$   
 Axles with hub reduction  
 2-circuit travel brakes

### Superstructure

Counterweight 2600 kg

### Safety and Comfort

Safety bar for control levers  
 Hose rupture valve on boom  
 Hydraulic refuelling pump, 90 l/min  
 Overload indicator  
 Lights:  
   headlights,  
   full and dipped beam  
   asymmetrical, halogen  
 Brakelights  
 Rear lights  
 Direction indicators  
 Rotating beacon  
 Hazard flashers  
 3 working lights, front, halogen  
 1 working light, rear, halogen  
 Instrument lighting  
 Illuminated cab, engine compartment and fuel filling compartment  
 Rear view mirrors,  
   4 exterior, 1 interior  
 Cab heating with 14 outlets  
 Ergonomically designed and adjustable operator's seat, with heating coils  
 Adjustable steering wheel  
 Filtered air intake  
 Cab skylight

Sliding window in the cab door  
 Emergency exit through rear window  
 Tinted windows (clear front)  
 Internal sun visor  
 Double intermittent windscreen wipers  
 Windscreen washers  
 Compressor horn  
 Radio cassette player

### Hydraulics

Float position on boom  
 Three variable axial piston working pumps  
 Mode selector, 3 steps  
 Power boost  
 Dual main valve for the travel and equipment functions  
 Standard filter cartridges for return, leak oil and respiration filter systems  
 Swing-out oil cooler  
 Hydraulic equipment for quickfit  
 Hammer hydraulics

### Equipment

4,65 m monobloc boom  
 2,8 m dipper arm  
 Hydraulic quickfit  
 End dampening on all cylinders  
 Security lifting hook  
 Friction welded piston rod eyes

## OPTIONAL EQUIPMENT *(Standard on certain markets)*

### Engine and Electrical System

Electric over speed protector  
 Volvo dieseldriven engine and cab heater with digital timer  
 Immersion heater, 220 V  
 Precyclone with exhaust ejector

### Undercarriage

Twin wheels  
   11.00 – 20 PR16  
   12.00 – 20 PR16  
 Single tyres  
 Solid tyres  
 Mud guards  
 Stone protection rings  
 Widening rings 2 x 50 mm  
 Oscillating outriggers plates  
 Tool box  
 Tow hook

### Superstructure

Counterweight  
   1750 kg  
   2200 kg

### Safety and Comfort

Protective grid for front pane/roof pane  
 Fire extinguisher  
 Seat belts  
 Protection against overfilling fuel  
 Extra circulation pump for the heating system  
 Extra hose rupture valves  
 Exterior glare shields  
 Rear window jalousie  
 Air conditioning  
 Micro filter for the cab  
 Cruise controller

### Hydraulics

Biologically degradable oil  
 Hydraulic equipment for:  
   slope bucket  
   grab  
   roto-tilt  
   jib  
   crusher  
   shears  
 Installation of a 4th working pump

### Equipment

5,2 m monobloc boom  
 5,1 m 2-piece boom  
 2,0 m and 2,4 m dipper arm  
 Extra headlights on the boom

Under our policy of continuous product improvement, we reserve the right to change specifications and design without prior notice. The illustrations do not necessarily show the standard version of the machine.

# Volvo Construction Equipment

Ref. No. 23 2 430 0011 BRITISH  
 Printed in Sweden 02.05.95 EXC