

VOLVO BACKHOE LOADERS

BL71, BL71 PLUS



MORE CARE. BUILT IN.



INSPIRED BY YOU. BUILT FOR YOU.

The Volvo BL71 Backhoe Loader is the result of years of research into what customers wanted most. Volvo then built a machine that provides everything you expect - durability, power, quality and environmental care. The result is a machine that gets the job done and keeps coming back for more.

Designed to fit your needs

Although the blueprints for Volvo's BL71 Backhoe Loader were drafted by a skilled team of Volvo engineers, the inspiration for its design was taken from construction industry professionals just like you. By incorporating direct customer input into every phase of development, Volvo engineers were able to create a reliable, value-priced machine that brings increased profitability to any size operation.

Tried and tested

To ensure the BL71 Backhoe Loader met the highest levels of quality applied to all Volvo products, the machine was put through rigorous on-site tests to prepare it for the daily assault of deep trenching, heavy lifting, loading, craning and more. But the real strength of its design lies in the fact that the entire machine - from loader to bucket - functions as one focused system capable of delivering reliable, productive operation year after year.

Proven power plant

The Volvo BL71 is equipped with a proven Volvo turbo diesel engine capable of delivering 70 kW / 94 HP (74.5 kW / 100 HP for BL71 Plus) of consistent and responsive power. The machine's Powershuttle gearbox features four fully synchronized gears and electro-hydraulic switching between forward and reverse. For better balance, the transmission is mounted directly to the engine.

Durability within

The quality and durability all begins at the ISO9001-certified factory and is built with care and attention to detail into every Volvo BL71 frame, component and part. The chassis of the Volvo BL71 is built tough for extended life. Every hydraulic line, fitting pin and bolt is corrosion protected and all hydraulic fittings employ O-ring face seal technology to ensure dry hydraulic joints. All electrical components are of the highest quality and all connections feature a waterproof, snap-together design.



- Volvo engine delivers reliable power.



- More care, built in from the ground up.



- Quality and safety ensured with state of the art technology.



- Designed and built for your work.
- Toughness you can see and feel.



GET READY TO BREAK NEW GROUND.

With customer-driven engineering at its foundation, and power and reliability throughout, the Volvo BL71 was born to dig. And with better dig depths, breakout forces and operating capacities than virtually every competitive model in its price class, its operation will move you as well.

Built to perform

The BL71's boom has a closed box-welded construction with fewer components and fewer welds for superior strength. The kingpost is composed of cast iron to allow flexible movement and swing while maintaining uncompromising strength.

Power to execute

To dig into those tough sites, the backhoe provides a 4.3 m dig depth and 59 kN (13263 lbs) of bucket dig force. The narrow, S-style boom provides excellent visibility and load capacity to simplify digging and loading operations. For safe roading, the boom can be hydraulically locked and there's a locking pin to secure the swing arm in place.

Added versatility

Few machines offer more versatility than the Volvo Backhoe Loader. With a wide assortment of versatile attachments, you've got the flexibility of an entire fleet of machines. Choose a simple-to-use mechanical attachment bracket or an optional hydraulic attachment bracket that allows you to save time and effort by quickly changing buckets from the operator's station. You can also get an auxiliary hydraulic circuit to operate attachments, such as a hammer.

We're flexible

In today's jobsite, you demand a backhoe loader that can adapt to your work. That's why the Volvo BL71 has optional features like an extendible dipper. And because operators are as diverse as the jobs, the Volvo BL71 offers added versatility and comfort with the choice of excavator or backhoe control patterns.

Go with the right flow - every time

For the ultimate in power, efficiency and comfort, the Volvo flow sharing load-sensing hydraulic system is the perfect match. When your hydraulic flow requirements increase, the system decreases the reference speed.

This automatically maintains pressure and flow for each and every hydraulic function. It's one of the industry's most advanced load-sensing hydraulic systems and it will give you the response you're looking for.

Enjoy greater smoothness of operation and high precision controls. The harmony and independence of movements in all jobsite conditions means increased power, productivity and comfort. There is no need to take corrective actions on the lever so you can get the job done faster for greater profits.



- Narrow S-style boom: do more, see more.



- Quick, easy backhoe attachment bracket.



- Powerful breakthroughs in productivity.



- Flow sharing load-sensing hydraulics.
- Standard hydraulic boom lock helps save time.
- Smooth, precise pilot control efficiency.



A

VOLVO

MAKE EVERY LOAD COUNT.

When it's time to backfill a trench or load a truck, you want it to be done quickly and efficiently. Volvo took what it learned from over 50 years of producing its Wheel Loaders to develop a loader that makes you more productive - with faster cycle times, outstanding lift capacity and easy operation.

Strength you can see

The Volvo BL71's loader features box-weld construction with a large reinforced cross tube and friction-welded dual lift cylinders. This provides strength without excessive weight for greater lifting capacity and better visibility.

Pick up the pace

Nothing improves productivity like fast, efficient work. The single, center-mounted dump cylinder provides 55 kN (12364 lbs) of breakout force, so you can handle the load with speed and ease. Featuring a patented self-leveling system, the BL71 offers faster, smoother operation and better soil retention.

Take control of every load

You're in control of the backhoe loader built for comfort. The state-of-the-art loader is pilot operated and the multi-function control lever simplifies loading operations. The comfort-grip joystick allows for precision operation with minimal effort of all loader functions: raise, lower, tilt, return-to-dig and float. Simply push the roller switch integrated on the joystick to open and close the multi-purpose bucket. There's also a transmission forward/reverse button and disconnect button on the joystick to speed up cycle times.

A powerful shift in productivity

The optional Powershift transmission helps you increase productivity with four forward and reverse speeds and a standard kick down for fast, smooth shifting from second to first gear. For ease of operation, a fully automatic mode is activated when fourth gear is engaged. Powershift makes your job a lot easier so that you not only get more done, you do it with speed and comfort.

The capacity to load more

The Volvo BL71 features a 1.0 m³ General Purpose Standard Bucket that gives you the capacity to move more material with every load, for faster cycle times and increased profitability. For the ultimate in flexibility, an optional Multi-Purpose Bucket lets you perform up to nine separate functions.

Loads of possibilities

For the ability to take on numerous jobs, the Volvo attachment bracket provides the connection. Quickly and easily change from one attachment to another - right from the comfort of your seat. It's fast, safe and productive - with the ability to use a range of attachments from selected other Volvo machines.



- Versatile loader attachment bracket.



- Automatic Powershift transmission.



- Efficient multi-function joystick.



- Pallet forks for added versatility.
- Plenty of power for all applications.
- Ideal tyre traction in all conditions.



- The BL71 shares commonality with Volvo Compact Wheel-Loader TPV attachments.
- The BL71 has all-round versatility.

TAKE COMFORT IN THE DETAILS.

Volvo understands you work long, hard hours. We also know that you don't always work in ideal conditions. That's why we spent so much time developing the operator's station that gives you the comfort you deserve - and the ease of operation you demand. Get comfortable with Volvo production.

It's all right where you want it

Inside the cab, controls are ergonomically placed on the right side console and front console indicators are right in your field of vision. The roomy operator's station offers a tilt steering column that adjusts to any sized operator. Comfortable grips and responsive handling makes it easy to raise, lower, tilt, return-to-dig and float with precision and speed. Adjustable vents are strategically positioned. Separate heating and optional air conditioning systems increase comfort and extend your operating season. Enjoy ample storage for tools, chains and more. The removable, cushioned floor mat is textured so water runs out the doors.

See your productivity rise

Flat windows provide no distortion and 360° visibility. The front and rear side windows can also be partially or fully opened for ventilation. A one-piece, floor-to-ceiling rear window opens easily for greater visibility. The rear window stores easily overhead and provides an overhang to protect the operator's feet from rain. Two front and two rear standard work lights give you excellent visibility in low-light conditions.

At the seat of comfort

Get more comfort features - regardless of your size - with the Volvo suspension seat. The Slam Back system lets you easily rotate the seat positions with one hand. Multiple comfort adjustments include lumbar support, height, weight, and fore and aft movement. There's a standard retractable seat belt and an optional heated air suspended seat for even more

comfort. Optional Boom Suspension System offers a smoother ride for better bucket material retention.

Take control of your comfort

Increase production with optional joystick pilot controls, although the joystick control columns are independent from the seat, you can control the joysticks with your wrists, while your forearms rest comfortably on the seat armrests and your back is against the seatback. This allows the operator to enjoy ergonomic comfort, greater precision and the ease of operation of a hydraulic excavator. Joystick control columns are fully adjustable. For easy use of the optional extended dipper, simply push the roller switch integrated on the right hand side joystick. An optional valve lets you change from standard backhoe to excavator controls based on operator preference.

Take control of every load

You're in control of the backhoe loader built for productivity, ease of operation and comfort. The state-of-the-art loader is pilot operated and the multi-function control lever simplifies loading operations. The comfort-grip joystick allows for precision operation with minimal effort of all loader functions: raise, lower, tilt, return-to-dig and float. Simply push forward and backward the roller switch integrated on the joystick to open and close the multi-purpose bucket. There's also a transmission forward/reverse button and disconnect button on the joystick to help speed up cycle times.



- Air conditioning circulates through eight air vents.



- Tilting steering column.



- Easily rotate the seat with one hand.



- Ergonomic controls reduce fatigue.
- Precise, easy pilot control comfort.
- The Volvo cab: built for your comfort.



VOLVO IS ALWAYS THERE FOR YOU.

If it's not running, you're losing money. That's why Volvo made the BL71 so easy to service and so safe to operate. Reliable, productive machines, easy access serviceability and safety that puts your mind at ease. These are Volvo priorities and they are the cornerstones of the Volvo BL71.

Open wide

Easy maintenance means more uptime and greater profits. For easy, total access to the engine compartment, simply release the hood latch and lift the tilt-up hood with one hand.

More care. Built in.

Fluid fills and checks are on the left side of the engine and all engine filters are on the right side.

The tilting hydraulic/transmission oil cooler allows easy access and cleaning. The Volvo BL71 was designed for fast and simple maintenance with 50-hour greasing intervals.

Safe on the outside

The Volvo BL71 has a variety of features that make it safer to service, transport and work near. The integrated, heavy-duty loader safety strut holds the loader safely in the raised position. When you want to dig or transport the machine, the stabilizers add extra safety by locking anti-drift valves.

Safe on the inside

Entering and exiting the machine is simplified with three steps and easy-to-reach handrails. Climb aboard and work confidently with a retractable seat belt, rear view mirror. Enjoy excellent all-around visibility from large, flat windows and narrow cab pillars. Instrumentation provides audio and visual warnings of machine functions. The interlocking brake pedals give you the option of single or double pedal braking, for tighter turning and sure stopping power.

Protect your investment

A single key operates all locks: doors, ignition, hood, fuel cap and toolbox for simplicity and vandal protection. A standard battery disconnect switch prevents unwanted machine use and adds more safety.

Performance for the long haul

Volvo Backhoe Loaders are backed by a standard warranty to keep you running. With the strongest global dealer network always ready to assist you with parts and service, extended warranty programs and more, you have everything you need for maximum uptime, greater productivity and increased profitability. Contact your local dealer, and get started today.



- Easy and safe access.



- Tilting cooler for easy cleaning.



- 50-hour greasing intervals, and all greasing points are accessible from the ground level.



- Easy air filter change.
- Rely on quick Volvo parts availability.
- Lift the full access hood with one hand.



SPECIFICATIONS

Engine

Low emission engine, with reduced fuel consumption.

Model	Volvo D4D
Type	Parent bore
N° of cylinder	4
Displacement	4038 cm ³
Aspiration	Turbo
Compression ratio	19:1
Power (Gross SAE)	BL71: 70kW / 94hp BL71Plus: 74.5kW / 100 hp
Rated speed	2200 rpm
Max torque	390 Nm @ 1,500 rpm

Electrical system

Rated volt age	12 V
Battery capacity	110 Ah
Alternator rating	95 Amps

Hydraulic system

Flow sharing system: when the control valve is performing two or more functions simultaneously, flow sharing automatically maintains the pressure and flow for each function.

System	Close center
Type	Load Sensing
Pumps type	Variable flow
Distributor	"Flow Sharing"
Max flow	160 l/min
Working pressure	250 bar
System capacity	130 l

Double regulating piston pump.

Steering

Orbitrol type steering valve given priority in hydraulic system.

Type	Load sensing hydrostatic
Turns lock to lock	4

Turning radius:

Between walls	5.3 m
----------------------	-------

Turning radius:

Curb-curb	4 m
------------------	-----

Weight

(Standard machine with 4 in 1 loader bucket, 600 mm backhoe bucket, counterweight, operator and full fuel tank, extendible dipper)

Operating weight	8594 kg
-------------------------	---------

Brakes

Multi-plate, oil immersed, power assisted, self-adjusting disc brakes with four wheel braking automatically engaged in third and fourth gear.

Total integral braking on the 4 wheels, when 4WD engaged

Type	Oil immersed disc brakes
Number of dics	2 for each wheel
Parking and safety brake	Dedicated disc on axle input shaft

Drivetrain

Final drive type	External planetaries
Total oscillation angle	16°
Differential locking	1

Front axle

Load rating, Static	24218 kg
Load rating, Dynamic	9687 kg

Rear axle

Load rating, Static	19120 kg
Load rating, Dynamic	7648 kg

Transmission

Powershuttle gear box with four forward and four reverse fully synchronized gears. Electro-hydraulic forward/reverse switch on the steering column and on the loader joystick.

Travel speed

Maximum speed, forward/reverse

1	5.8 km/h (3.6 mph)
2	9.3 km/h (5.8 mph)
3	18.8 km/h (11.7 mph)
4	37.6 km/h (23.4 mph)

Optional Powershift transmission with four forward and reverse speeds and a standard kick down shift control for immediate shifting from second to first gear. Automatic mode is activated when fourth gear is engaged.

Travel speed

Maximum speed, forward/reverse

1	5.9 km/h (3.6 mph)
2	9.7 km/h (6 mph)
3	19.5 km/h (12.1 mph)
4	36.9 km/h (22.9 mph)

Service fill capacities

Cooling system	19 l
Fuel tank	120 l
Engine oil (w/filter)	14 l

Rear axle

Differential oil capacity	14.5
----------------------------------	------

Front axle (4WD)

Differential oil capacity	6.5 l
Hydraulic reservoir	41 l
Hydraulic system	130 l

Backhoe performance

The boom is of a curved design for easier truck loading.

Standard dipper

Bucket width	610 mm
Bucket capacity	0.20 m ³
Bucket digging force	59.1 kN
Dipper digging force	39.6 kN

Extendible Backhoe: performance

Bucket capacity	0.20 m ³
Bucket digging force	59.1 kN

Dipper digging force

Ret -	39.6 kN
Ext -	28.9 kN

Bucket rotation	194°
Swing torque	26 kNm

Loader performance

Standard loader is a self-leveling, single cylinder loader type.

Volvo patented system.

Bucket width	2350 mm
Bucket capacity	1.0 m ³
Lifting capacity at full height	3154 kg
Bucket Breakout force	55.4 kN

Features:

Return-to-dig	Standard
Lube interval (hrs)	> 50
Number of bucket cylinders	1
Boom Suspension System	Optional

Tyres

Large front tyres give great loading performance.



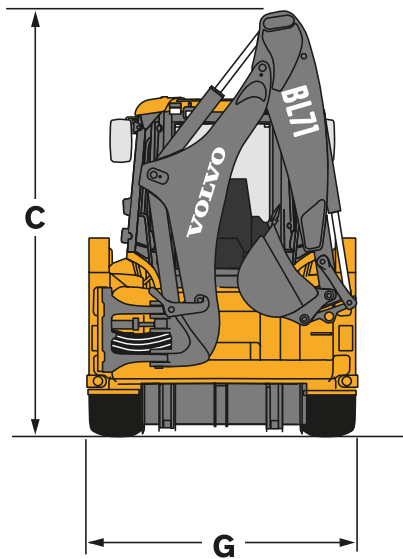
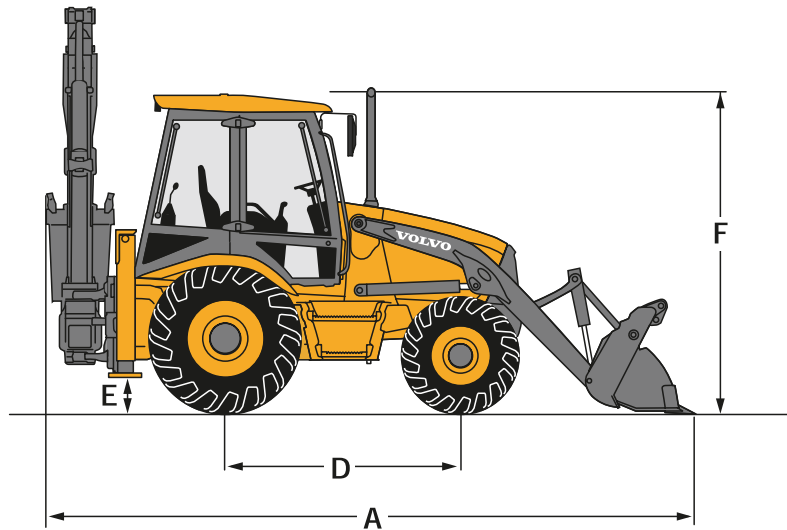
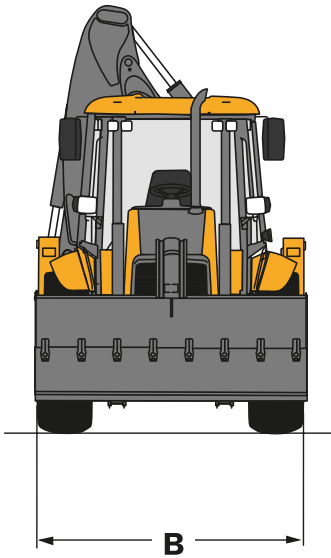

Rear: 18,4 x 26





Front: 16/70 x 20

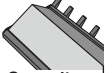

Dimensions - Transport Position

A - Overall length	5825 mm
B - Overall width	2477 mm
C - Overall height	3706 mm
D - Wheelbase 4wd	2148 mm
E - Stabiliser clearance	370 mm
F - Height to top of ROPS (cab)	2936 mm
G - Stabiliser Width	2300 mm

Backhoe buckets	 Width	 Weight	 Capacity	 Teeth nbr.
Standard bucket	2350 mm	450 kg	1000 l	8
4 in 1 bucket	2350 mm	784 kg	1000 l	8

Backhoe buckets	 Width	 Weight	 Capacity	 Teeth nbr.
Standard bucket	300 mm	90 kg	74 l	3
	400 mm	101 kg	110 l	3
	450 mm	109 kg	128 l	4
	610 mm	126 kg	190 l	4
Grading bucket	910 mm	164 kg	309 l	6
	1215 mm	135 kg	160 l	0
	1515 mm	158 kg	210 l	0

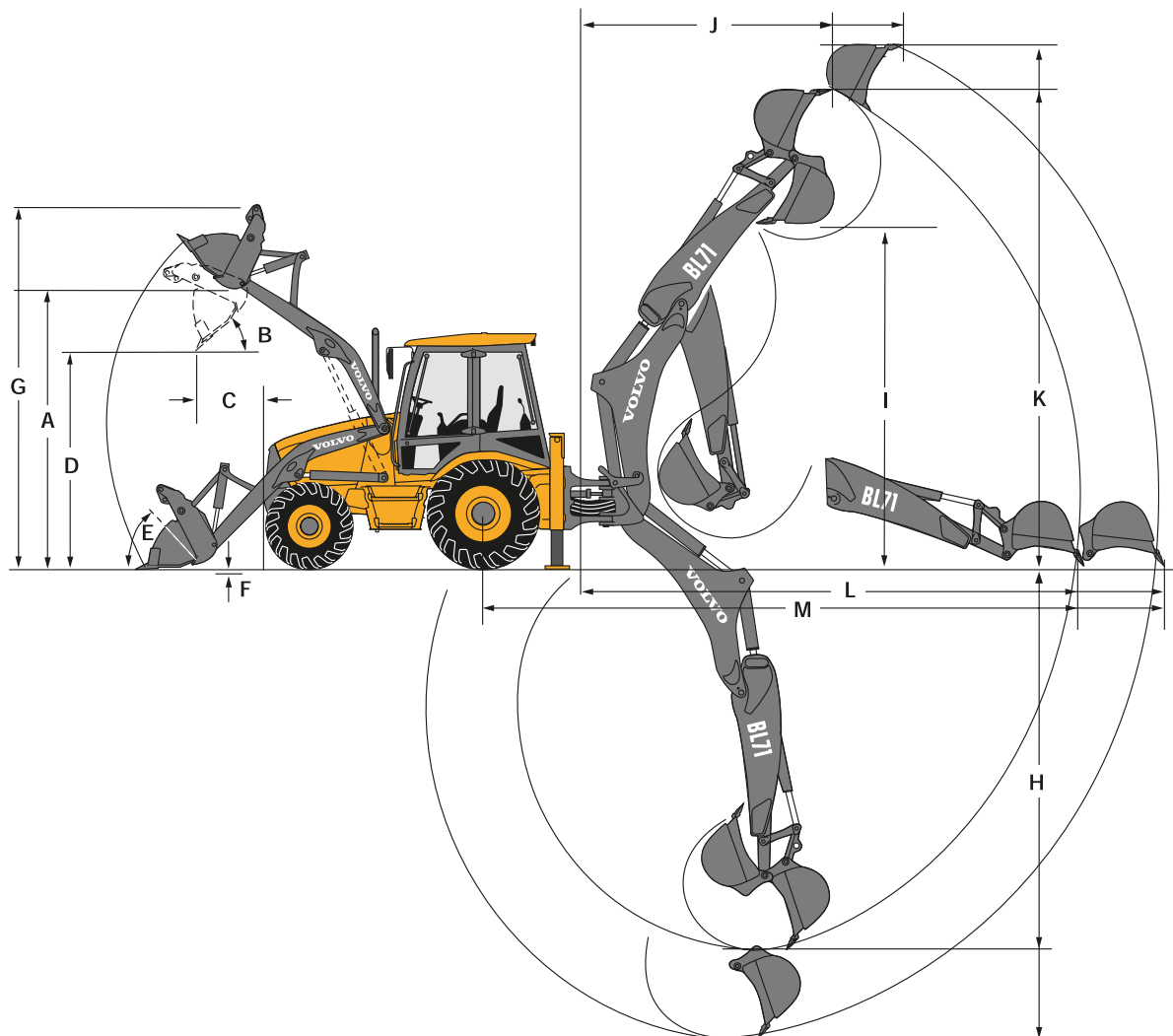

Loader dimensions

A - Height to hinge pin	3459 mm
B - Dump angle	49°
C - Dump reach @ 45°	836 mm
D - Dump height @ 45°	2716 mm
E - Rollback at ground	44 °
F - Dig depth below grade	156 mm
G - Overall operating height	4468 mm
Max grading angle	117°

Backhoe dimensions

Standard dipper

H - SAE max digging depth	4280 mm
I - Loading clearance	3899 mm
J - Reach at max height	2886 mm
K - Max operating height	5545 mm
L - Reach from swing post	5806 mm
Sideshift offset from centreline	574 mm

Extendible dipper dimensions

H - SAE max digging depth	Ret - 4280 mm	Ext - 5343 mm
	<hr/>	
I - Loading clearance	Ret - 3899 mm	Ext - 4509 mm
	<hr/>	
J - Reach at max height	Ret - 2886 mm	Ext - 3764 mm
	<hr/>	
K - Max operating height	Ret - 5545 mm	Ext - 6155 mm
	<hr/>	
L - Reach from swing post	Ret - 5806 mm	Ext - 6782 mm
	<hr/>	

STANDARD EQUIPMENT

Engine

BL71: Volvo D4D turbocharged diesel engine (70 kW).
BL71 Plus: Volvo D4D turbocharged diesel engine (74,5 kW).
Engine fan guard.
Ground line fuel fill with 120 liter capacity.
Front grill.
Tilting cooler.

Electrical System

Battery, 690 CCA.
Alternator 95 Amp.

Service and Maintenance

Tool box - external.
50-hour greasing intervals.

Hydraulic System

Hydraulic oil cooler.
Load sensing, variable flow system with axial piston pump.
"Flow Sharing" System.

Lighting

Hazard flasher/direction indicators.
Light, working (2 front, 2 rear).
Front headlights.

Instrumentation & controls

Gauges:

- Coolant temperature
- Fuel level
- Hour recorder
- Headliner
- Radio ready

Warning and control lamps:

- Preheating element engine
- High coolant temperature engine
- Low oil pressure engine,
- Air filter engine,
- High oil temperature transmission,
- Service indicator
- Battery charging
- Hydraulic oil filter
- High hydraulic oil temperature
- Low hydraulic oil temperature
- Warning and control lamps.

Power socket (2).

Horn.

Warning buzzer.

Reversing alarm.

Throttles, hand and foot.

Driveline

Four wheel drive.

Oil immersed disc brakes.

Differential lock.

Fast reversing shuttle, all gears.

Torque convertor.

Four-speed synchromesh transmission.

Neutral transmission button on loader joystick.

Transmission de-clutch on loader joystick.

Tyres.

Cab, Exterior

Left/right side doors with locks.
4 side opening windows with partial & full hold open.

One-piece opening rear window.

Front windscreen - laminated.

Mirrors external (2).

All tinted glass.

Cab, Interior

Interior light.

Drink holder.

Ignition switch.

Front and rear windscreen wipers.

Front and rear windscreen washer.

Floor mat.

Seat with fabric or vinyl seat cover with or without arm rests.

Defroster.

Seat belt, retractable.

Tilt steering wheel.

Power steering.

Hydrostatic heater.

Working Equipment

Backhoe, side-shift, excavator - two lever control.

Hydraulic boom transport lock.

Sideshift, locking.

Lifting eye backhoe.

Swing transport lock.

Loader, self-levelling with return-to-dig and transmission disconnect switch on loader joystick.

OPTIONAL EQUIPMENT

Cab

Air Conditioning.
Air suspension and heated seat + arm rests.
Radio.
Speedometer.
Sun visor.
Wide seat belt.

Driveline

Powershift transmission.
Front fenders.

Working Equipment

Excavator Pilot Controls.
Boom suspension system.
Extendible dipper.
Stabiliser street pads.

Hydraulics

Hammer hydraulic circuit.
Hammer rigid line.
Hand held hydraulic.
Bi-Directional Auxiliary hydraulic circuit.

Lighting

Additional working lights (2 front, 2 rear).

Electrical System

Battery, additional.
Engine pre-heater.

Safety

Hydraulic oil tank lockable cap.
Rotating beacon.
Boom and dipper safety valves.
Loader safety valve.
Vandal guard.
Anti-theft key board.
Back up alarm.

Special colours.

ATTACHMENTS

Loader

Loader Attachment Bracket (TPV)
General Purpose bucket.

Multi-Purpose bucket.
Forks kit for Loader Attachment Bracket.
Flip-over forks for GP and MP buckets.

Excavator

Standard and Heavy Duty buckets.
Mechanical attachment bracket.
Hydraulic attachment bracket.

Volvo breaker HB 440.



Volvo Construction Equipment is different. It's designed, built and supported in a different way. That difference comes from an engineering heritage of over 170 years. A heritage of thinking first about the people who actually use the machines. About how to help them be safer, more comfortable, more productive. About the environment we all share. The result of that thinking is a growing range of machines and a global support network dedicated to helping you do more. People around the world are proud to use Volvo. And we're proud of what makes Volvo different – **More care. Built in.**



All products are not available in all markets. Under our policy of continuous improvement, we reserve the right to change specifications and design without prior notice. The illustrations do not necessarily show the standard version of the machine.

VOLVO

Construction Equipment

www.volvoce.com

Ref. No. 21 A 100 2689
Printed in Sweden
Volvo, Belley

English
2006.12
BHL