

VOLVO WHEEL LOADER

L70D

STARTING WITH SERIAL NUMBER 18093

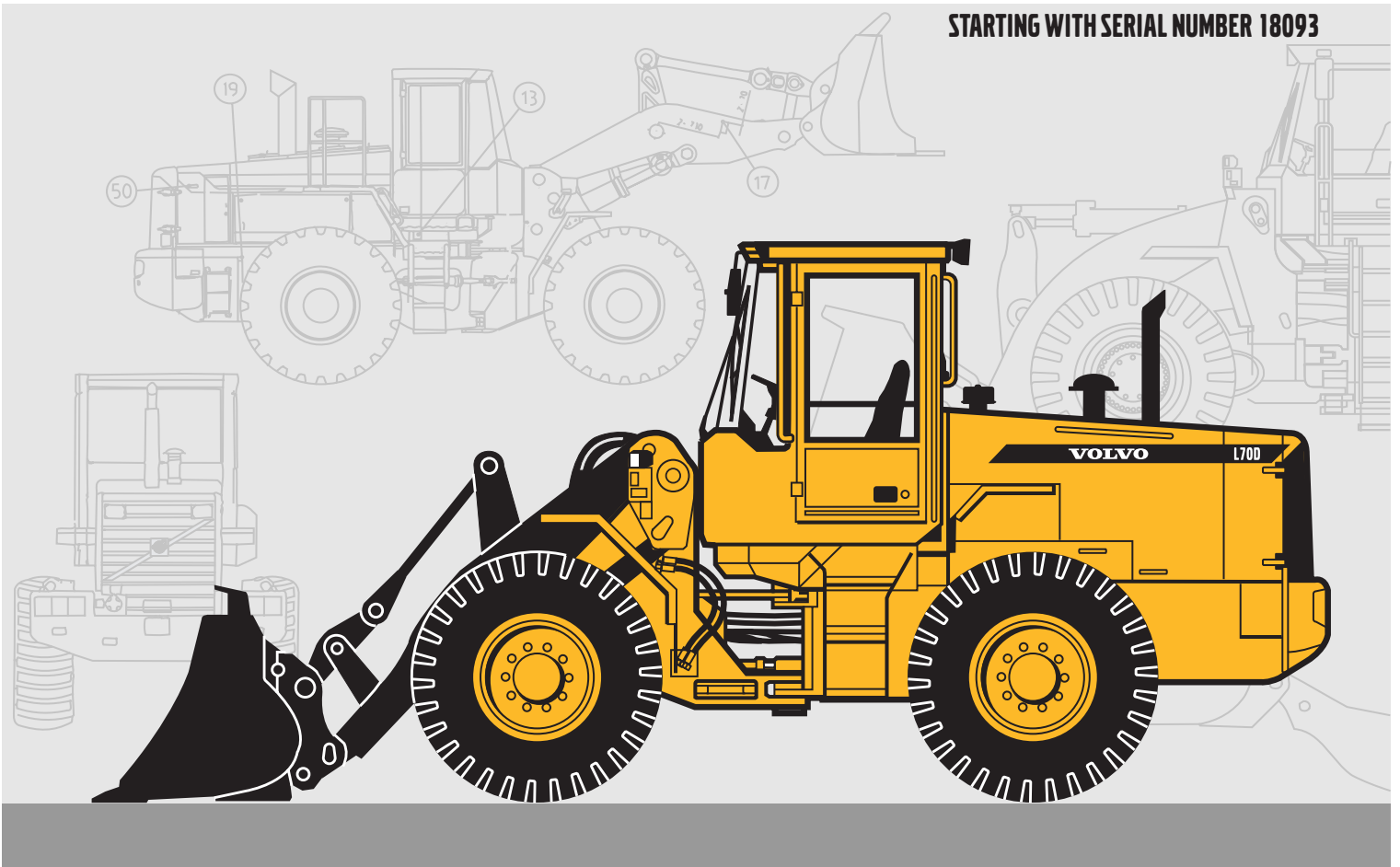

- **Engine output SAE J1995:**
gross 96 kW (130 hp)
ISO 9249, SAE J1349:
net 91 kW (124 hp)
 - **Operating weight:** 10,9–12,2 t
24,000–26,900 lb
 - **Bucket volume:** 1,6–5,0 m³
2.1–6.5 yd³
 - **Volvo high-performance, low-emission engine**
 - Excellent low rpm performance
 - Meets all known exhaust emission regulations for offroad vehicles
 - **Volvo transmission with APS II**
 - 2nd generation Automatic Power Shift with mode selector
 - Optimizes performance
 - **Wet disc brakes**
 - Fully sealed, oil-circulation cooled, outboard mounted
 - **Torque Parallel Linkage**
 - High breakout torque throughout the working range
 - Excellent parallel lift-arm action
 - **Care Cab II**
 - Pressurized cab with high comfort and safety
 - **Contronic II monitoring system**
 - **Load-sensing working hydraulics and steering system**
 - **Pilot-operated working hydraulics**
 - **Optional equipment**
 - Power take-off for hydraulically powered attachments
 - Hydraulic attachment bracket
 - Boom Suspension System
 - Comfort Drive Control
- Other options, see back page**

VOLVO



SERVICE

The Contronic II monitoring system provides information on machine condition, routine maintenance schedules and minimizes time required for troubleshooting.

Service accessibility: Large, easy-to-open engine access doors with gas struts. Swing-out radiator grille and radiator.

Refill capacities .. l	US gal	Refill capacities .. l	US gal		
Fuel tank	190	50.2	Gearbox	17	4.5
Engine coolant ...	40	10.6	Engine oil	16	4.2
Hydraulic tank	65	17.2	Axle front / rear ...	24/24	6.3/6.3



ENGINE

The engine offers high torque and quick response at low rpm also under full load. The machine operates at low engine speeds, which contributes to good fuel economy, less noise, less wear and longer life.

Engine: High performance, low emission 6-cylinder, in-line, direct-injected, turbocharged, intercooled 4-stroke diesel engine with wet replaceable cylinder liners.

Air cleaning: three-stage.

Engine Volvo TD 63 KGE		
Max power at	35 r/s	2 100 r/min
SAE J1995 gross	96 kW	130 hp
ISO 9249, SAE J1349 net ...	91 kW	124 hp
With optional noise reduction kit EU2002	93 kW	126 hp
Rated power at	36,6 r/s	2 200 r/min
SAE J1995 gross	94 kW	128 hp
ISO 9249, SAE J1349 net ...	89 kW	122 hp
With optional Noise reduction kit EU 2002	92 kW	125hp
Max. torque at	18,3 r/s	1 100 r/min
SAE J1995 gross	595 Nm	439 lbf ft
ISO 9249, SAE J1349 net ...	590 Nm	435 lbf ft
Displacement	5,48 l	334 in³

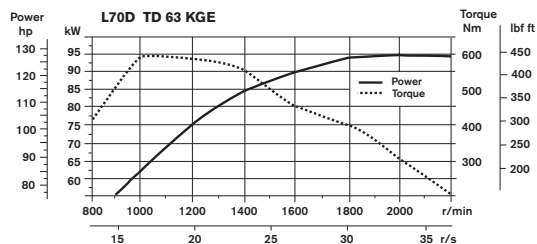

ELECTRICAL SYSTEM

Contronic II monitoring system with increased function control and capability to store data for analysis. Electrical system with circuit boards, well protected by fuses. The system is pre-wired for installation of optional equipment.

Central warning system: Central warning light for the following functions (buzzer with gear engaged): Engine oil pressure, transmission oil temperature, brake pressure, parking brake applied, steering system pressure, coolant temperature, transmission oil temperature, hydraulic oil temperature, overspeeding in engaged gear, computer malfunction.

Voltage	24 V
Batteries	2x12 V
Battery capacity	2x105 Ah
Cold cranking capacity, ea	690 A
Reserve capacity, ea	185 min
Alternator rating	1 680 W / 60 A
Starter-motor output	5,4 kW 7.3 hp



DRIVETRAIN

The drivetrain and working hydraulics are well-matched to each other and of reliable design. Quick acceleration boosts productivity. Volvo system-compatible design facilitates servicing.

Torque converter: Single-stage

Transmission: Volvo Countershaft-type transmission with single-lever control. Fast and smooth directional and speed shifting.

Shifting system: Volvo Automatic Power Shift (APS II) with mode selector.

Axles: Volvo axles, fully floating with shafts and planetary-type hub reductions. Cast-steel axle housing. Fixed front axle and oscillating rear axle. 100% differential lock on front axle.

Transmission	Volvo HT 90
Torque multiplication	2,85:1
Speeds, max. forward/reverse ..	High range Low range (Opt.)
	km/h mph km/h mph
1	7,0 4.3 1,9 1.2
2	14,0 8.7 3,7 2.3
3	26,0 16.2 7,3 4.5
4	44,0 27.3 13,6 8.5
Measured with tires	20.5 R25* L2
Front axle	Volvo / AWB 15
Oscillation, rear axle	±13°
Ground clearance at 13° oscillation	420 mm 16.5 in



BRAKE SYSTEM

A simple and reliable brake system that ensures high availability and safety. Self-adjusting oil circulation-cooled wet disc brakes give long service intervals.

Service brakes: Volvo, dual-circuit system with nitrogen-charged accumulators. Fully hydraulically operated, enclosed, internal oil-circulation cooled disc brakes. Transmission declutch during braking can be preselected by a switch on the instrument panel. Brake performance test included in the Contronic II system.











Parking brake: Mechanically operated drum brake on front axle input shaft. Electro-hydraulically operated (option).

Secondary brake: Either the service brake circuits or the parking brake fullfills the safety requirements.

Standards: The brake system complies with the requirements of ISO 3450, SAE J1473.

Number of discs/wheel	1
Number of accumulators	3
Volume, each	0,5 l 30.5 in³

OPERATIONAL DATA, VOLVO L70D**





	GENERAL PURPOSE						GRADING	LIGHT MATERIAL			
											
Tires 20.5 R25	Bolt-on edge	Bolt-on edge	Bolt-on edge	Teeth	Teeth	Teeth		Bolt-on edge	Bolt-on edge	Bolt-on edge	
Volume, heaped ISO/SAE	m ³ yd ³	1,9 2.5	1,9 2.5	1,7 2.2	1,6 2.1	1,8 2.4	1,8 2.4	1,6 2.1	3,1 4.1	3,1 4.1	5,0 6.5
Volume at 110% fill factor	m ³ yd ³	2,1 2.7	2,1 2.7	1,9 2.5	1,8 2.4	2,0 2.6	2,0 2.6	– –	3,4 4.5	3,4 4.5	5,5 7.2
Static tipping load, straight	kg lb	8 730 19,250	8 260 18,210	8 820 19,440	8 510 18,760	8 890 19,600	8 390 18,500	7 360 16,230	8 270 18,230	7 820 17,240	7 810 17,220
at 35° turn	kg lb	7 810 17,220	7 370 16,250	7 900 17,420	7 600 16,760	7 970 17,570	7 490 16,510	6 570 14,480	7 370 16,250	6 950 15,320	6 900 15,210
at full turn	kg lb	7 540 16,620	7 100 15,650	7 630 16,820	7 330 16,160	7 690 16,950	7 230 15,940	6 330 13,960	7 110 15,670	6 690 14,750	6 640 14,640
Breakout force	kN lbf	86,9 19,540	79,4 17,850	92,5 20,800	88,8 19,960	91,9 20,660	83,6 18,790	61,6 13,850	65,7 14,770	61,1 13,740	53,2 11,960
A	mm ft in	7 120 23'4"	7 220 23'8"	7 050 23'1"	7 270 23'10"	7 240 23'9"	7 340 24'1"	7 460 24'6"	7 480 24'6"	7 570 24'10"	7 790 25'7"
E	mm ft in	990 3'3"	1 090 3'7"	920 3'0"	1 140 3'9"	1 110 3'8"	1 200 3'11"	1 300 4'3"	1 340 4'4"	1 430 4'8"	1 650 5'5"
H *)	mm ft in	2 880 9'6"	2 820 9'3"	2 930 9'7"	2 790 9'2"	2 810 9'3"	2 740 9'0"	2 580 8'6"	2 650 8'8"	2 590 8'6"	2 440 8'0"
L	mm ft in	5 060 16'7"	5 120 16'10"	5 000 16'5"	5 060 16'7"	5 070 16'7"	5 120 16'10"	4 540 14'11"	5 220 17'2"	5 290 17'4"	5 490 18'0"
M *)	mm ft in	960 3'2"	1 030 3'5"	910 3'0"	1 080 3'7"	1 050 3'6"	1 130 3'9"	1 080 3'6"	1 230 4'0"	1 310 4'4"	1 500 4'11"
N *)	mm ft in	1 540 5'1"	1 580 5'2"	1 520 5'0"	1 610 5'3"	1 590 5'3"	1 630 5'4"	1 490 4'11"	1 580 5'2"	1 620 5'4"	1 670 5'6"
V	mm ft in	2 500 8'2"	2 500 8'2"	2 500 8'2"	2 500 8'2"	2 500 8'2"	2 500 8'2"	2 500 8'2"	2 550 8'4"	2 550 8'4"	2 650 8'8"
a ₁ clearance circle	mm ft in	11 130 36'6"	11 170 36'8"	11 100 36'5"	11 200 36'9"	11 190 36'9"	11 240 36'10"	11 510 37'9"	11 370 37'4"	11 410 37'5"	11 640 38'2"
Operating weight	kg lb	11 330 24,980	11 570 25,510	11 290 24,890	11 470 25,290	11 270 24,850	11 530 25,420	11 450 25,240	11 510 25,380	11 750 25,900	12 040 26,540

*) at 45° dump angle **) attachment data applies only to original Volvo attachments

BUCKET SELECTION CHART

The choice of bucket is determined by the density of the material and the expected bucket fill factor. The actual bucket volume is often larger than the rated capacity, due to the TP linkage features: • Open bucket design. • Very good roll back in positions. • Good bucket fill performance.

Example: Sand and gravel. Fill factor ~ 105%. Density 2865 lb/yd³. Result: The 2.3 yd³ bucket carries 2.4 yd³. For optimum stability, always consult the bucket selection chart.

Material	Bucket fill %		Material density		ISO/SAE bucket volume		Actual volume	
			t/m ³	lb/yd ³	m ³	yd ³	m ³	yd ³
Earth/Clay	~ 110		~ 1,8	~ 3035	1,6	2.1	~ 1,8	~ 2.3
			~ 1,6	~ 2695	1,8	2.3	~ 2,0	~ 2.6
			~ 1,4	~ 2360	2,0	2.6	~ 2,2	~ 2.9
Sand/Gravel	~ 105		~ 1,9	~ 3200	1,6	2.1	~ 1,7	~ 2.2
			~ 1,7	~ 2865	1,8	2.3	~ 1,9	~ 2.5
			~ 1,5	~ 2530	2,0	2.6	~ 2,1	~ 2.7
Aggregate	~ 100		~ 1,9	~ 3200	1,6	2.1	~ 1,6	~ 2.1
			~ 1,7	~ 2865	1,8	2.3	~ 1,8	~ 2.3
			~ 1,6	~ 2695	2,0	2.6	~ 2,0	~ 2.6
Rock	≤ 100		~ 1,7	~ 2865	1,6	2.1	~ 1,6	~ 2.1

The size of rock buckets is designed for optimal penetration and filling capability rather than the density of the material.

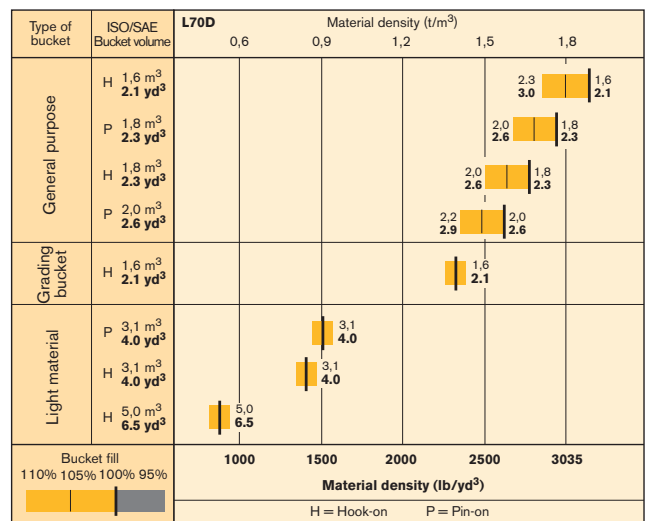

SUPPLEMENTAL OPERATING DATA

No additional counterweight available	Tires				Add extended fenders			
	17.5 R25* L2		17.5-25* L3					
Width over tires	mm	in	-90	3.5	+60	2.4	-	-
Ground clearance	mm	in	-60	2.4	+25	1.0	-	-
Operating weight	kg	lb	-330	730	+160	355	+200	440
Tipping load, full turn	kg	lb	-190	420	+80	175	+245	540

OPERATIONAL DATA & DIMENSIONS

Tires: 20.5 R25* L2

B	3 920 mm	12'10"
C	2 840 mm	9'4"
D	430 mm	1'5"
F	3 210 mm	10'6"
G	2 135 mm	7'0"
J	3 590 mm	11'9"
K	3 880 mm	12'9"
O	56°	
P	45°	
R	44°	
R ₁ *	48°	
S	78°	
T	50 mm	0'2"
U	440 mm	1'5"
X	1 860 mm	6'1"
Y	2 390 mm	7'10"
Z	3 170 mm	10'5"
a ₂	5 100 mm	16'9"
a ₃	2 710 mm	8'11"
a ₄	±40°	

* Carry position SAE

Where applicable, specifications and dimensions are in accordance with ISO 7131, SAE J732, ISO 7546, SAE J742, ISO 5998, SAE J818, and ISO 8313.

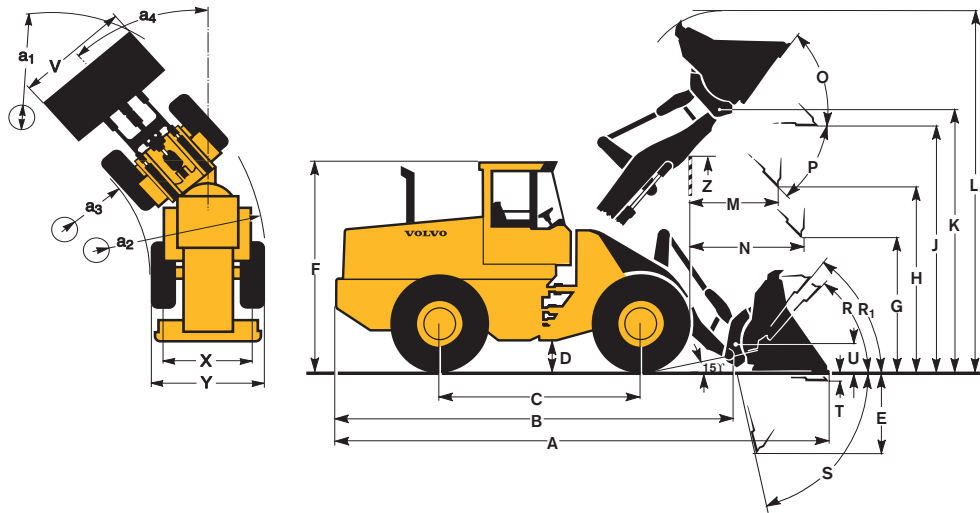

MATERIAL HANDLING ARM (Hook on)

Tires: 20.5 R25* L2

A	1 620 kg	3572 lb
B	1 280 kg	2822 lb
C	1 050 kg	2315 lb
D	2 510 mm	8'3"
E	1 940 mm	6'4"
F	1 410 mm	4'8"
G	3 260 mm	10'8"
H	4 300 mm	14'1"
I	5 430 mm	17'10"
J	1 020 mm	3'4"
K	1 370 mm	4'6"
L	1 760 mm	5'9"
M	2 190 mm	7'2"
N	3 170 mm	10'5"
O	4 230 mm	13'11"
P	1 500 mm	4'11"
Q	5 320 mm	17'5"
R	6 210 mm	20'4"
S	7 190 mm	23'7"

Order No: 92007
Operating weight: 11 200 kg (24,700 lb)

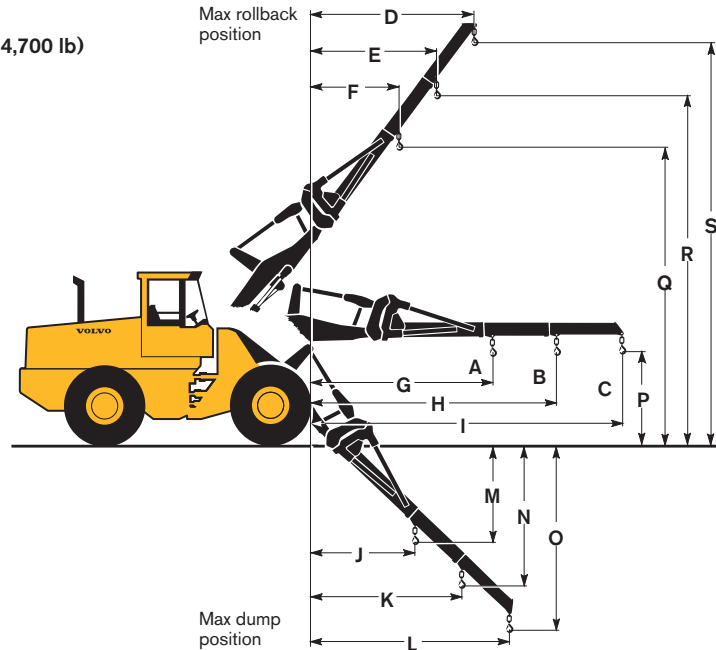

PALLET FORK (Hook on)

Tires: 20.5 R25* L2

A	840 mm	2'9"
B	1 560 mm	5'1"
C	80 mm	0'3"
D	1 830 mm	6'0"
E	3 730 mm	12'3"
F	670 mm	2'2"

Fork tine order no. (R/L): 93525/93526
Length: 1 200 mm 3'11"
Fork frame order no: 80041
Width: 1 500 mm 4'11"
Rated operating load*: 4 290 kg 9,460 lb
at load center distance: 600 mm 2'0"
Operating weight: 11 250 kg 24,800 lb
Incl. optional counterweight

* acc. std EN 474-3, firm and level ground

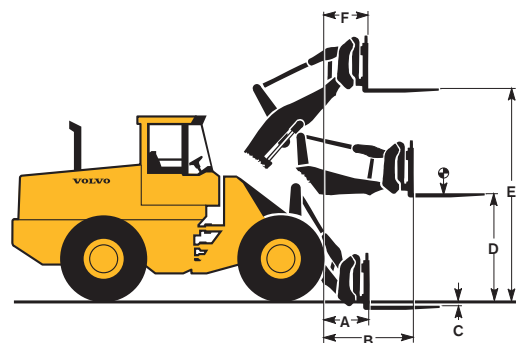



STEERING SYSTEM

Low effort steering provides fast work cycle times. Power-efficient system provides good fuel economy, good directional stability and smooth ride.

Steering system: Load-sensing hydrostatic articulated steering.

System supply: The steering system has priority feed from a load-sensing axial piston pump.

Pump: Double variable-flow axial piston pump.

Cylinders: Two double-acting cylinders.

Steering cylinders	2	
Bore	63 mm	2.48 in
Piston rod diameter	40 mm	1.57 in
Stroke	370 mm	14.57 in
Relief pressure	21 MPa	3046 psi
Max. flow	80 l/min	21.13 US gpm
Articulation	±40°	



CAB

Care Cab II with easy entry and wide door opening. Inside of cab lined with noise-absorbent materials. Sound and vibration suppressing suspension. Good all-round visibility through large glass areas. Curved front windshield of green-tinted glass. Ergonomically positioned controls and instruments permit a comfortable operating position.

Instrumentation: All important information is centrally located in the operator's field of vision. Center console display for Contronic II monitoring system.

Heater and defroster: Heating element with filtered fresh air and fan with four speeds. Defroster vents for all window areas.

Operator's seat: Operator's seat with adjustable suspension and retractable seatbelt. The seat is mounted on a bracket on the rear cab wall. The forces from the retractable seatbelt are absorbed by the seat rails. Meets ISO/DIS 7096-1997.

Standard: Tested and approved according to the following standards: ROPS (ISO/CD 3471, SAE J1040), FOPS (ISO 3449, SAE J231). Complies with "Overhead guards for rider lift trucks" (ISO 6055) and "Operator Restrain System" (SAE J386).

Emergency exits	2	
Sound level in cab ISO 6396	71 dB (A)	
External sound level		
According to ISO 6395	LwA 106 dB (A)	
According to EU 2002 requirements ...	LwA 104 dB (A)	
According to Blue Angel	LwA 101 dB (A)	
Ventilation	9 m ³ /min	318 ft³/min
Heating capacity	11 kW	37,500 Btu/h
Air conditioning (optional)	8 kW	27,300 Btu/h



HYDRAULIC SYSTEM

The Load-Sensing hydraulic system delivers the exact amount of oil required for the function used. At the same time, complete control of the hydraulics is achieved throughout the entire lifting range. The high capacity of the pumps results in quick and smooth movements.

System supply: One load-sensing double axial piston pump with variable displacement. The steering function always has priority.

Valves: Double-acting 2-spool valve. The main valve is controlled by a 2-spool pilot valve.

Lift function: The valve has four positions: raise, hold, lower and float position. Inductive/magnetic automatic boom kickout can be switched on and off and is adjustable to any position between maximum reach and full lifting height.

Tilt function: The valve has three functions: rollback, hold and dump. Inductive/magnetic automatic bucket positioner, can be switched on and off.

Cylinders: Double-acting cylinders for all functions.

Filter: Full-flow filtration through 20 micron (absolute) filter cartridge.

Axial piston pump		
Relief pressure	26,0 MPa	3771 psi
Flow	160 l/min	42.3 US gpm
at	10 MPa	1450 psi
and engine speed	36,7 r/s	2 200 rpm
Pilot system		
Relief pressure	3,0 MPa	435 psi
Cycle times		
Raise*	5,4 s	
Dump*	1,1 s	
Lower, empty	3,0 s	
Total cycle time	9,5 s	

* with load as per ISO 5998 and SAE J818



LIFT-ARM SYSTEM

The TP Linkage combines high breakout torque throughout the working range with parallel lift-arm action. These features together with high lift height and long reach make the lift-arm system equally as good in bucket loading as in work with fork attachments and material handling arms.

Lift cylinder	2	
Bore	100 mm	3.9 in
Piston rod diameter	70 mm	2.8 in
Stroke	734 mm	28.9 in
Tilt cylinder	1	
Bore	150 mm	5.9 in
Piston rod diameter	80 mm	3.1 in
Stroke	440 mm	17.3 in

STANDARD EQUIPMENT

Engine

High performance, low emission
Volvo TD 63 KDE
Dual fuel filters
Cold starting aid
Air cleaner, dry type, dual element,
exhaust-aspirated precleaner
Coolant level, sight gauge
Muffler, spark arresting
Coolant filter
Fan guard
Primary fuel filter with water
separator

Electrical System

24 V – prewired for optional
accessories
Alternator, 24 V, 60 A
Battery disconnect switch
Gauges:
• Fuel gauge
• Engine coolant temperature
gauge
• Transmission oil temperature
gauge
• Hourmeter
Horn, electric
Instrument panel with symbols
Lights:
• Driving (2-front), halogen head
lights with high/low beam
• Parking lights
• Stop/tail combination (2 rear)
• Turn signals with separate hazard
warning switch
• Halogen working lights
(2 front/2 rear)
• Instrument lighting
• Reverse alarm (SAE J994)

Contronic II

Monitoring System, ECU with log and analysis system

Contronic II display
Engine shutdown to idle
• High engine coolant temperature
• Low engine oil pressure
• High transmission oil temperature
Neutral start feature
Brake performance test function
Test function for warning and
indicator lights
Warning and indicator lights:
• Alternator malfunction
• Oil pressure, engine
• Oil pressure, transmission
• Brake pressure
• Parking brake applied
• Hydraulic oil level
• Hydraulic oil temperature
• Axle oil temperature
• Primary steering
• High beams
• Turn signals
• Rotating beacon
• Preheating coil
• Differential lock (front axle)
• Coolant temperature
• Transmission oil temperature
• Brake charging
• Air cleaner restriction
• Hydraulic oil level
• High speed/gear
• Overspeed engine

Drivetrain

Transmission: modulated with single
lever control, Automatic Power
Shift (APS II) with mode selector
and operator-controlled declutch
Forward and reverse switch on
hydraulic control console
Tires 17.5R25 L2
100% differential lock, front axle

Brake System

Wet, internal oil-circulation cooled,
outboard-mounted disc brakes,
4-wheel, dual circuit brake system
Secondary brake system,
accumulator supplied
Parking brake

Cab

ROPS (SAE J1040) (ISO 3471),
FOPS (SAE J231) (ISO 3449).
Acoustical lining
Ashtray
Cigarette lighter
Cab access steps and handrails
Dual service brake pedals
Door lockable (left side)
Heater/defroster/pressurizer
with four speed blower fan
Filtered air
Floor mat
Dome light
2 interior rearview mirrors
2 exterior rearview mirrors
Openable window, right-hand side
Steering wheel, adjustable tilt and
telescopic, adjustable lever
console
Tinted safety glass
Retractable seat belt (SAE J386)
Ergonomically designed operator's

seat with adjustable suspension
Storage compartment
Sun visor
Beverage holder
Windshield wiper, front and rear
Intermittent wiper, front
Windshield washer, front and rear

Hydraulic System

Main valve, 2-spool, pilot-operated
Pilot valve, 2-spool
Boom-lowering, stopped engine
Dual axial piston pump
Bucket lever detent
Hydraulic control lever safety latch
Hydraulic pressure test ports, quick
connect
Hydraulic fluid level, sight gauge
Hydraulic oil cooler
Bucket leveler, automatic with posi-
tion indicator, adjustable
Boom lever detents
Boom kickout, automatic, adjustable
Hydraulic pressure test port, quick
connect

External Equipment

Attachment bracket, hydraulic, with
separate locking system
Isolation mounts: cab, engine, trans-
mission, radiator
Lifting and tie-down lugs
Side panels, engine hood
Steering frame lock
Vandalism lock, provision for:
batteries, engine oil
Drawbar hitch
Fenders front/rear
Fuel fill strainer

OPTIONAL EQUIPMENT *(Standard in certain markets)*

Service and Maintenance

Tool box
Automatic lube system

Engine

Coolant pre-heater (120 V/750 W)
or (240 V/750 W)
Pre-cleaner, oil bath type
Pre-cleaner, turbo type

Electrical System

Alternator 100 A
Working lights front, extra
Working lights rear, extra
Rotating beacon, amber with
collapsible mount

Drivetrain

Transmission, 8-speed
Limited slip differential, rear
Limited slip differential, front and
rear

Cab

Installation kit for radio
AM/FM radio with tape deck

Heated operator seat
Armrest, left side
Seat belt, 3 in, extended length
Sliding window, right side
Hand throttle
Air suspended operator's seat
Air conditioner
Noise reduction kit, cab
Parking brake alarm
Open ROPS version
Sunblinds
Ventilation filter for asbestos
environment

Hydraulic System

Hydraulic control, 3rd function
Hydraulic control, 4th function
Hydraulic controls, 5th/6th function
Hydraulic power take off, heavy duty
Hydraulic single-acting lifting
function
Boom Suspension System
Biodegradeable hydraulic fluid
Lever detent 3rd function
Artic kit
Single lever control

External Equipment

Fenders, axle-mounted rear
Fender wideners

Other Equipment

Comfort Drive Control (CDC)
Slow moving vehicle sign
Secondary steering
Electro-hydraulically operated
parking brake

Tires

20.5-25, 20.5R25*, 555/70 R25

Protective Equipment

Guards for:
• Headlights
• Rear working lights
• Rear lights
• Windshield
• Air cleaner restriction
Cover plate under cab
Belly guards, front and rear

Attachments

Buckets:
• Straight with/without teeth
• Spade nose with/without teeth
• High tip
• Light material
Three piece, reversible bolt-on
cutting edge
Bolt-on and weld-on bucket teeth
Log grapples
Fork equipment
Material handling arm
Diagonal snow blade
Broom
Attachment rib kit

Under our policy of continuous product improvement, we reserve the right to change specifications and design without prior notice. The illustrations do not necessarily show the standard version of the machine.

VOLVO

Volvo Construction Equipment
North America Inc.

One Volvo Drive, Asheville, N.C. 28803-3447

Ref. No. 22 2 669 2319
Printed in USA 03/01- 5,0