

VOLVO WHEEL LOADER

L220E



VOLVO

L220E – BUILT FOR HIGH PRODUCTIVITY

The Volvo L220E is a smart machine. Perhaps the smartest ever. And we're not just referring to all the innovative solutions we've built into it. After all, the point of any wheel loader is moving material as cheaply and quickly as possible. And this is where the L220E excels. Thanks to its low rev engine, perfectly matched drivetrain and wide range of attachments, the L220E can move more material per unit of fuel than any competing wheel loader. Ultimately, it's the machine that allows you to get a lot more done with a lot less effort.

The Volvo L220E features an electronically-controlled, high-performance, low-emission Volvo engine, fully automatic countershaft transmission, a load sensing hydraulic system, Volvo's unique Torque Parallel Linkage (TP Linkage) and the comfortable Volvo Care Cab. The L220E is a concentration of smart solutions, making it an extremely powerful and operator friendly machine. At the end of the day, it's the only choice if you want to move more material for every unit of fuel.

More work, less effort

The interplay between a powerful engine and a smart transmission always ensures rapid response, while the steering system makes maneuvering smooth and precise at all times. TP Linkage, with its superior breakout torque and penetration, allows the L220E to attack the material and fill the bucket to capacity. The result is quicker, more relaxed work cycles. In fact, the L220E is an operator's dream - a truth that becomes immediately apparent as soon as you step into the cab. All the levers and controls are exactly where you expect them to be - ergonomically-designed, easy-to-use and easy-to-read. The air is clean and fresh and noise levels are low. Volvo's Care Cab is quite simply the most advanced operator environment on the loader market today.

A great deal for your investment

Proven reliability, excellent financing, extremely low fuel consumption and a high trade-in value provide the cornerstones of a safe investment. Add to that outstanding handling and productivity, a market-leading operator environment to protect the person in the machine, quick and simple daily maintenance and modest service requirements.

And what do you get? The most cost efficient loader in its class, delivering unparalleled profitability - both now and in years to come.

With the L220E, everybody is a winner. Quite simply, a great deal for your money.



Specifications L220E

Engine:	Volvo D12C LB E2	
Max. power at	26,7 r/s	(1600 r/min)
SAE J1995 gross:	259 kW	(352 hp)
ISO 9249,		
SAE J1349 net:	258 kW	(351 hp)
Breakout force:	222,9 kN*	(50,110 lbf)
Static tipping load		
at full turn:	20 740 kg*	(45,720 lb)
Buckets:	4,5-14,0 m ³	(5.9-18.3 yd³)
Log grapples:	1,7-4,0 m ²	(18.3-43.1 ft²)
Operating weight:	31,0-33,0 t	(68,340-72,750 lb)
Tires:	29,5 R25	
	875/65 R29	

* Bucket: 5,4 m³ **(7.1 yd³)** with bolt-on edges,
Tires: 29,5 R25 L4, Standard boom



THE ART OF MOVING MOUNTAINS AS CHEAPLY AND QUICKLY AS POSSIBLE

Load more tons per hour with the Volvo L220E. Its powerful engine and the fully Automatic Power Shift (APS) gearshifting system provide immediate response even in the toughest conditions. And the Volvo axles are designed to ensure that the rimpull is there when needed. The result is high productivity and unparalleled economy.

Rapid response for high productivity and low operating costs

Even when idling, the 12 liter, high-performance engine delivers an impressive 92% of maximum torque. The machine responds quickly and forcefully with excellent rimpull, full hydraulic power, low fuel consumption and low-emissions. And thanks to the low rpm performance, the service life of the engine is extended. With the L220E, you've got an unbeatable combination of high productivity and low operating costs – both now and in the years ahead.

Fully automatic shifting

The Volvo fully-automatic countershaft transmission provides smooth and effective gearshifting in all gears. All the operator has to do is select forward or reverse and APS automatically selects the right gear according to both engine rpm and ground speed.

Volvo axles keep you on the ground

Volvo's in-house engineered axles and drivetrain are well-matched and designed for top dependability. The front axle features a standard 100% differential lock and the rear axle trunion mount is maintenance-free, meaning less downtime for daily maintenance.

Give yourself a brake

The L220E features oil circulation-cooled wet disc brakes, designed for smooth, effective braking and, of course, a long service life.

The external axle oil cooler* provides additional cooling for tough applications, and furthermore, the axle oil is filtered, which greatly increases the life cycle of the oil.

Engine

- Volvo D12C, a turbocharged, air-to-air intercooled, low-emission engine with electronically-controlled fuel injection, overhead camshaft and 4 valves per cylinder delivers high torque even at low rpm.
- To optimize performance, the engine's computer communicates with all other systems, ensuring quicker response, lower fuel consumption and faster work cycles.
- The electronically-controlled hydrostatic fan is only activated when necessary, thus saving fuel.

Transmission

- With Volvo's third generation of APS, the operator can select between four different operating modes, including the new AUTO function, which adaptively chooses the most convenient shifting program for the job at hand, equally weighing the operator's driving habits together with the operating cycle.
- The third generation APS now has fully automatic shifting 1-4, meaning all the operator has to do is choose forward or reverse.

Axles

- A two-stage axle oil temperature alert provides effective protection of components and a longer service life.
- Standard 100% differential lock on the front axle for easy operation even in tough underfoot conditions.
- Permanently lubricated rear axle trunion mount bearings never require greasing.

Brakes

- Oil circulation-cooled wet disc brakes ensure effective braking and a long service life.
- An electronic brake test in Contronic gives you instant access to the status of the brakes.
- A brake wear indicator on each wheel allows you to easily check the brake pad wear.

* Optional equipment

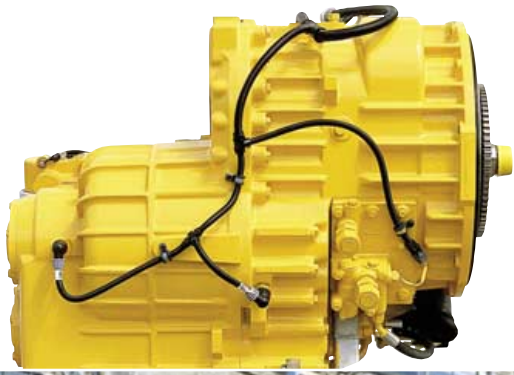

A SMART MACHINE DOESN'T WEAR OUT QUICKLY

Torque Parallel Linkage (TP Linkage), load sensing hydraulics, smooth steering and stable operation help make the L220E a precision performer. No unnecessary energy is wasted pumping excess oil around the hydraulic system, which ultimately means you can load more material per unit of fuel with a L220E than any competing machine in its class.



TP Linkage – a breakthrough in the industry

The reliable TP Linkage, Volvo's patented lift-arm system, delivers high breakout torque and parallel action throughout the entire lifting range. The system is exceedingly user-friendly, and the operator can easily handle heavy materials and maintain full control in all positions.

Hydraulics that make sense

The L220E features an intelligent load sensing hydraulic system. Three variable piston pumps provide the exact flow and pressure required at any given moment, distributing power when and where it's needed. When the hydraulic system isn't being used, the entire engine output is transferred to the drivetrain. In addition to rapid response, the system facilitates smoother operation, lower fuel consumption and precise control, even at low rpm.

Precision steering makes it easy to maneuver

Steering is easy, yet precise, even at low rpm. The load sensing hydrostatic steering system is only activated when the wheel is turned, which means that neither fuel nor power is wasted.

Smooth on rough surfaces

With a long wheelbase, the L220E is smooth and stable even on rough surfaces. Volvo's Boom Suspension System (BSS)* features gas/oil accumulators to help absorb shocks and smooth out rough roads.

TP linkage

- Unique, patented lift-arm system provides two solutions in one: excellent breakout torque and parallel action throughout the entire lifting range.
- Compact geometry keeps the bucket close to the machine, providing stable load and carry work.

Load-sensing hydraulics

- The load sensing hydraulic system ensures that hydraulic oil is pumped around the system only when and where it's needed. This guarantees greater efficiency and lower fuel consumption.
- Pilot-operated hydraulics allow precise control of the attachments, making life easier and safer for the operator.

Steering

- Load sensing steering only uses power when it's needed, thereby saving fuel.
- E-series loaders feature an accumulator system, providing stable, smooth steering and greater safety.

Frame

- Rugged frame design for secure mounting of components reduces vibrations and increases service life.
- Volvo's frame joint bearing design is a well-proven concept that's easy to maintain and renowned for its long service life.

* Optional equipment



AN ALERT OPERATOR IS A PRODUCTIVE OPERATOR

Volvo Care Cab reinforces Volvo's reputation as a leader in operator environments and cab comfort. We never forget the operator inside the machine. A comfortable, operator-friendly and safe environment makes the workday easier and more productive.



A clean and comfortable workplace

The right cab climate does wonders for efficiency, keeping operators sharp during long shifts. In fact, all incoming air is filtered in two stages, making this one of the cleanest cabs on the market. Even the recirculated air is filtered. Furthermore, Volvo's state-of-the-art air-conditioning* provides a pleasant temperature year-round, regardless of outdoor conditions. So even after a long work shift, the air in the cab is still fresh, and the operator's mind is still clear.

Comfort and productivity go hand-in-hand

There is a range of comfortable seats, all of them with multiple adjustment functions for optimal individual comfort. All instruments are visible at a glance, and all important information is right in front of the operator. The forward, reverse and Kick-down functions are situated both on the lever on the left-hand side of the steering wheel and on the hydraulic console to the right. And thanks to Comfort Drive Control (CDC)*, you can steer, change directions and Kick-down to first gear with easy-to-use controls integrated into the left-hand armrest - an excellent way to combat fatigue and static muscle strain. Furthermore, to avoid monotonous arm movements, you can shift at any time from lever steering to using the steering wheel.

Contronic keeps an eye on everything

Contronic, the highly reliable control and monitoring system from Volvo, continuously monitors the machine's operation and performance. The system is an electronic network made up of three computers. Operating at three levels, the system keeps an eye on the machine's various functions in real-time. If a potential problem should occur, the system generates an immediate warning, making the operator aware of the condition. All operating data is saved and can be used to analyze how the machine performs and also to trace its history since the latest service. The machine's functions can be updated for optimal adaptation to new and changing operating conditions via the Contronic service display tool. With VCADS Pro, it's also possible to check and adjust the machine's functions and performance characteristics.

Low noise levels

Thanks to its ingenious rubber mounting system and heavy-duty insulation, the Care Cab is one of the quietest cabs on the market. By reducing tiresome earfuls and annoying vibrations, the operator will stay sharp throughout the shift. In short, it's a great place to work.

Care Cab

- Unrivalled operator environment with one of the market's best cab filtration systems.
- Pleasant interior with superior finish makes it easy-to-maintain and keep clean.
- Adjustable seat, armrest, hydraulic lever console and steering wheel* for optimal operator comfort and high production.
- Contronic, a superior control and monitoring system, designed to increase safety and productivity.
- All service platforms and entry ladders boast improved anti-slip surfaces. Sloped entry ladder for easy cab access.
- Large windscreens, narrow pillars and a sloped engine hood ensure good panoramic visibility, thus further increasing safety.
- Powerful halogen lighting to the front and rear provides good visibility over the entire work area.

* Optional equipment



RAPID SERVICE FOR MAXIMUM AVAILABILITY

Few machines have to work in tougher environments than a wheel loader. And the machine has to keep running day in, day out – without downtime. Naturally, in the event that something occurs, we offer a wide range of service solutions specially adapted to the conditions you work in – the toughest imaginable. Our focus is to deliver what you expect - maximum productivity, year after year.

More time for productive work

Now that you can check your fluid levels electronically, daily maintenance is that much easier. Filters and service points are readily accessible from ground level. The service doors are large, easy-to-open and well supported with gas struts. The radiator grille and fan swing out for easy cleaning, and the pressure check ports and quick connect fittings are grouped together for quick and easy checks.

Contronic keeps an eye on everything

The machine's operation and performance are controlled and monitored by Volvo Contronic, a built-in electronic network made up of three computers. The system works on three levels.

Level 1: The system keeps an eye on the machine's functions in real-time. Should a potential problem occur, Contronic alerts the operator instantly. A service technician can then connect his Contronic service tool to the system and trace the fault on the spot.

Level 2: All operational data is stored and can be used to analyze the machine's performance and trace its history since the latest service. This information is then presented in the Machine Tracking Information System (MATRIS), providing valuable information for fault tracing and service measures.

Level 3: This allows the machine's functions to be optimized according to a change in working conditions via the Contronic service display. Thanks to the VCADS Pro analysis and programming tool, the machine's functions and performance can be monitored and adapted to changing conditions.



MATRIS (MACHINE TRACKING INFORMATION SYSTEM) stores operational data regarding the machine's performance. This is valuable information for troubleshooting and service.

Contronic electronic monitoring system

- Engine and machine data are coordinated for optimum performance and safety.
- Display information in three categories: operational data, warning messages and error messages.
- Available in 13 languages, and monitors fuel consumption data, cycle times and service intervals.
- Electronic level checks of key fluids make it easy for the operator to conduct daily checks from the comfort of his seat.
- Shutdown-to-idle safety function is automatically activated when a major problem occurs.

Maintenance and availability

- Electronic monitoring of fluid levels reduces time for daily checks.
- Long lubrication intervals allow more time for productive work.
- Well-designed platforms and well-positioned hand rails make daily maintenance and service safe and comfortable.

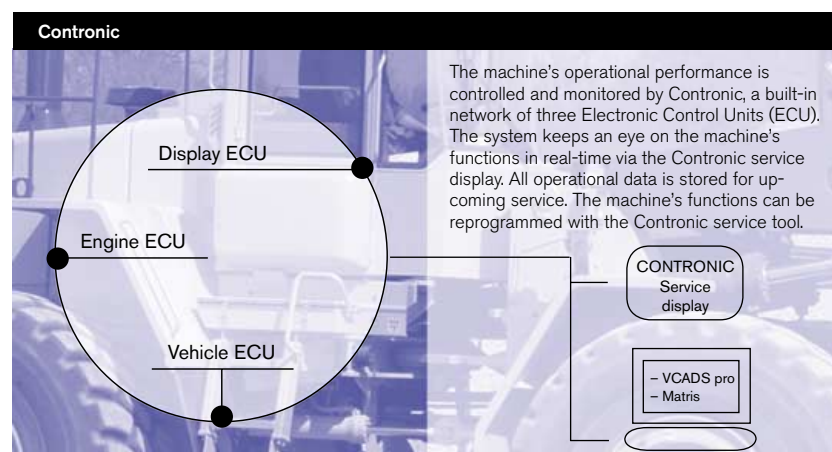



- Besides factory warranties, Volvo also offers extended warranties up to 8,000 hours. This Component Assurance Program (CAP) can be tailored to meet your needs.
- Readily accessible panels and service points simplify service.

VOLVO'S COMMITMENT TO NATURE AND MANKIND

Quality, safety and care for the environment are Volvo's core values. Indeed, we see our commitment as an integral part of our operation. Few machines have to work in tougher conditions. The ultimate goal is maximized productivity and efficiency for the lowest cost per hour, with minimized environmental impact. For instance, plants and manufacturing processes are certified in accordance with ISO 14001. This is but one example of our tangible commitments and high quality standards. And that's why Volvo customers get one of the most environmentally considerate and dependable wheel loaders on the market.

A winner for years to come

Your Volvo L220E has to be a winner – both in day-to-day and long-term operations, always operating economically with maximum consideration of the environment. The machinery has to be trusted in all aspects. It must deliver the anticipations of productivity and economy. High quality and easy maintenance are imperative for keeping up the work process. The high-performance, low-emission engine is both good for your business and for the environment.

Comfortable and quiet operator's environment

The operator inside deserves a comfortable, reliable and safe machine to work with. A good environment helps to spare operator, equipment and nature for years to come. The Volvo L220E is a super competitive wheel loader that puts the operator right in the middle, literally speaking. Tedious vibrations and noise have been heavily reduced. If the operator feels comfortable and secure, it's easier to stay attentive.

More than 95% recyclable

The L220E is almost completely recyclable. We see it as a natural step in our commitment. Components such as the engine, transmission and hydraulics are re-engineered and re-used in our Parts Exchange program. The equipment has to be as trustworthy, service-friendly, productive and as cost-effective as possible. Choose this wheel loader for maximum productivity and minimal impact on operator, machinery and environment. Feel free to feel secure in a Volvo L220E.

Quality

- The air is vented from all major components with easy-to-replace breather filters, used to prevent dirty air from entering the transmission, axles, fuel tank and hydraulic tank.
- All electrical wires are routed through sturdy conduits, protected from water, dust and abrasion with rubberized connectors and terminal caps.
- The L220E is designed from the beginning for easy service and maintenance. Easy access to all components lays the foundation for shorter service and maintenance time and longer life.

Safety

- A dual-circuit service brake system that fulfills all requirements according to ISO 3450, electronic brake test in Contronic and easy-to-check brake wear indicators are all ways to ensure safe and effective braking.
- Volvo Care Cab is tested and approved according to ROPS ISO 3471 and FOPS ISO 3449 standards.
- Optimized panoramic visibility gives effective control over the entire work area.
- The L220E has steps and platforms that are equipped with anti-slip surfaces and well positioned hand rails.

Environment

- The low rpm, high-performance D12C engine meets all current emission requirements according to step 2 legislation.
- The L220E is manufactured in environmentally certified factories according to ISO 14001.
- The L220E is more than 95% recyclable according to material weight.
- Low external and internal sound levels.



VOLVO L220E IN DETAIL

Engine

12 liter, 6-cylinder straight turbocharged diesel engine with 4 valves per cylinder, overhead camshaft and electronically-controlled unit injectors. The engine has wet replaceable cylinder liners and replaceable valve guides and valve seats. The throttle application is transmitted electrically from the throttle pedal or the optional hand throttle. Air cleaning: three-stage. Cooling system: Air-to-air intercooler and hydrostatic, electronically-controlled fan.

Engine	Volvo D12C LB E2
Max. power at	26,7 r/s (1,600 rpm)
SAE J1995 gross	259 kW (352 hp)
ISO 9249, SAE J1349	258 kW (351 hp)
Max. torque at	20,0 r/s (1,200 rpm)
SAE J1995 gross	1765 Nm (1,301 lbf ft)
ISO 9249, SAE J1349	1760 Nm (1,298 lbf ft)
Economic working range	1100–1600 rpm
Displacement	12 l (732 in ³)

Electrical system

Central warning system: Central warning light for the following functions (buzzer with gear engaged): Engine oil pressure, charge air temperature, transmission oil pressure, brake pressure, parking brake applied, hydraulic oil level, steering pressure, low coolant level, coolant temperature, transmission oil temperature, hydraulic oil temperature, overspeeding in engaged gear, brake charging, axle oil temperature, fuel temperature.

Voltage	24 V
Batteries	2x12 V
Battery capacity	2x170 Ah
Cold cranking capacity, approx	1150 A
Reserve capacity, approx	350 min
Alternator rating	1540 W/55 A
Starter motor output	7,0 kW (10.0 hp)

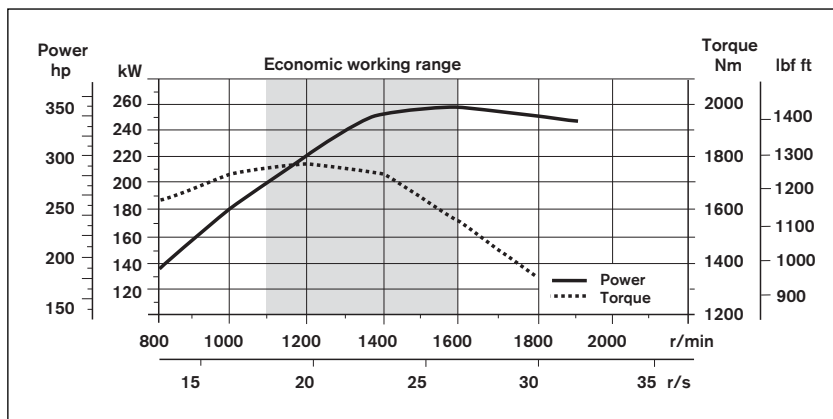

Drivetrain

Torque converter: single-stage. Transmission: Volvo countershaft transmission with single lever control. Fast and smooth shifting of gears between forward and reverse with Pulse Width Modulation (PWM) valve. Gear-shifting system: Volvo Automatic Power Shift (APS) with fully automatic shifting 1-4 and mode selector with four different gear shifting programs, including AUTO. Axles: Volvo fully-floating axle shafts with planetary hub reductions and cast steel axle housings. Fixed front axle and oscillating rear axle. 100% differential lock on the front axle.

Transmission	Volvo HTE 305
Torque multiplication	2,1:1
Maximum speed, forward/reverse	
1	6,8 km/h (4.2 mph)
2	11,0 km/h (6.8 mph)
3	22,2 km/h (13.8 mph)
4	32,8 km/h (20.4 mph)
Measured with tires	29.5 R25 L3
Front axle/rear axle	Volvo/AWB 50/41
Rear axle oscillation	±15°
Ground clearance at 15° osc.	620 mm (24.2 in)

Brake system

Service brake: Volvo dual-circuit system with nitrogen charged accumulators. Outboard-mounted, hydraulically-operated, fully sealed, oil circulation-cooled wet disc brakes. The operator can select automatic declutch of the transmission when braking through Contronic. Parking brake: Fully sealed, wet multi-disc brake built into the transmission. Applied by spring force and electro-hydraulically released with a switch on the instrument panel. Secondary brake: Dual brake circuits with rechargeable accumulators. Either one circuit or the parking brake fulfills all safety requirements. Standard: The brake system complies with the requirements of ISO 3450.

Number of brake discs per wheel front/rear	2/1
Accumulators	2x1,0 l (2x0.26 US gal)
	1x0,5 l (1x0.13 US gal)
Accumulators for parking brake	1x0,5 l (1x0.13 US gal)

Steering system

Steering system: Load sensing hydrostatic articulated steering. System supply: The steering system has priority feed from a load sensing axial piston pump with variable displacement. Steering cylinders: Two double-acting cylinders.

Steering cylinders	2
Cylinder bore	100 mm (3.94 in)
Piston rod diameter	60 mm (2.36 in)
Stroke	502 mm (19.76 in)
Working pressure	21 MPa (3,046 psi)
Maximum flow	234 l/min (61.8 US gpm)
Maximum articulation	±37°

Cab

Instrumentation: All important information is centrally located in the operator's field of view on the Contronic monitoring system's display unit. Heater and defroster: Heater coil with filtered fresh air and fan with four speeds. Defroster vents for all window areas. Operator seat: Ergonomic seat with adjustable suspension and retractable seatbelt. The seat is mounted on a bracket, which is mounted on the rear cab wall. The forces from the retractable seat belt are absorbed by the seat rail. Standard: The cab structure is tested and approved according to ROPS (ISO 3471) and FOPS (ISO 3449). The cab meets all requirements according to ISO 6055 (Operator Overhead Protection - Industrial Trucks) and SAE J386 (Operator Restraint System).

Emergency exits	1
Sound level in cab according to ISO 6396	LpA 75 dB (A)
External sound level according to ISO 6395 (Directive 2000/14/EC)	LwA 108 dB (A)
Ventilation	9 m ³ /min (318 ft ³ /min)
Heating capacity	11 kW (37,500 Btu/h)
Air-conditioning (optional)	8 kW (27,300 Btu/h)

Hydraulic system

System supply: Two load sensing axial piston pumps with variable displacement. The steering system always has priority. Valves: Double-acting 2-spool valve. The main valve is controlled by a 2-spool pilot valve. Lift function: The valve has four positions including raise, hold, lower and float. Inductive/magnetic automatic boom kickout can be switched on and off and is adjustable to any position between maximum reach and full lifting height. Tilt function: The valve has three functions including rollback, hold and dump. Inductive/magnetic automatic tilt can be adjusted to the desired bucket angle. Cylinders: Double-acting cylinders for all functions. Filter: Full-flow filtration through 20 micron (absolute) filter cartridge.

Working pressure maximum, pump 1	25,0 MPa (3,625 psi)
Flow at and engine speed	234 l/min (61.2 US gpm) at 10 MPa (1,450 psi) and 32 r/s (1,900 rpm)
Working pressure, pump 2	26,0 MPa (3,771 psi)
Flow at and engine speed	234 l/min (61.2 US gpm) at 10 MPa (1,450 psi) and 32 r/s (1,900 rpm)
Pilot system Working pressure	3,5 MPa (508 psi)
Cycle times	
Raise*	5,8 s
Tilt*	1,6 s
Lower, empty	3,2 s
Total cycle time	10,6 s

* with load as per ISO 14397 and SAE J818

Lift-arm system

Torque Parallel Linkage (TP Linkage) with high breakout torque and parallel action throughout the entire lifting range.

Lift cylinders	2
Cylinder bore	190 mm (7.5 in)
Piston rod diameter	90 mm (3.5 in)
Stroke	768 mm (30.2 in)
Tilt cylinder	1
Cylinder bore	260 mm (10.2 in)
Piston rod diameter	120 mm (4.7 in)
Stroke	455 mm (17.9 in)

Service

Service accessibility: Large, easy-to-open service doors with gas struts. Swing-out radiator grille and cooling fan. Possibility to log and analyze data to facilitate troubleshooting.

Refill capacities

Fuel tank	370 l (97.7 US gal)
Engine coolant	70 l (18.5 US gal)
Hydraulic oil tank	343 l (90.6 US gal)
Transmission oil	48 l (12.7 US gal)
Engine oil	48 l (12.7 US gal)
Axles front/rear	77/75 l (20.3/19.8 US gal)

SPECIFICATIONS

Tires: 29.5 R25 L4

Standard boom		Long boom	
B	7440 mm 24'5"	7750 mm	25'5"
C	3700 mm 12'2"	—	—
D	510 mm 1'8"	—	—
F	3730 mm 12'3"	—	—
G	2130 mm 7'0"	—	—
J	4260 mm 14'0"	4620 mm	15'2"
K	4680 mm 15'4"	5050 mm	16'7"
O	56 °	—	—
P _{max}	47 °	—	—
R	43 °	44 °	—
R ₁ *	47 °	—	—
S	65 °	62 °	—
T	90 mm 0'3.6"	—	—
U	590 mm 1'11"	—	—
X	2400 mm 7'10"	—	—
Y	3170 mm 10'5"	—	—
Z	4060 mm 13'4"	4400 mm	14'5"
a ₂	7110 mm 23'4"	—	—
a ₃	3940 mm 12'11"	—	—
a ₄	±37 °	—	—

* Carry position SAE

Tires: 875/65 R29 L4

A	4,0 m ²	43,1 ft ²
B	3900 mm	12'9"
C	2280 mm	7'6"
D	3140 mm	10'4"
E	1780 mm	5'9"
F	1620 mm	5'4"
G	3230 mm	10'7"
H	5330 mm	17'6"
I	7700 mm	25'3"
J	3620 mm	11'11"
K	3940 mm	12'11"
L	2650 mm	8'8"
M	10 380 mm	34'1"

Operating weight (incl. logging cw 800 kg (1,764 lb)):
32 490 kg (71,628 lb)
Operating load: 10 080 kg (22,222 lb)

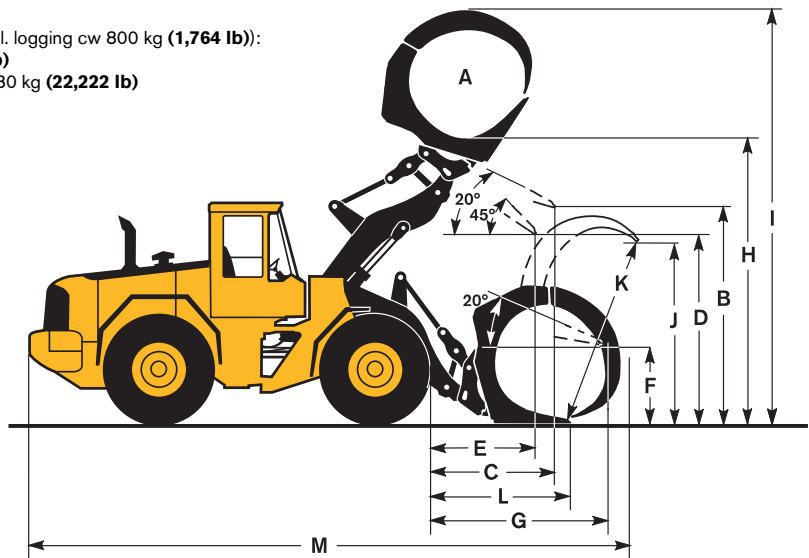



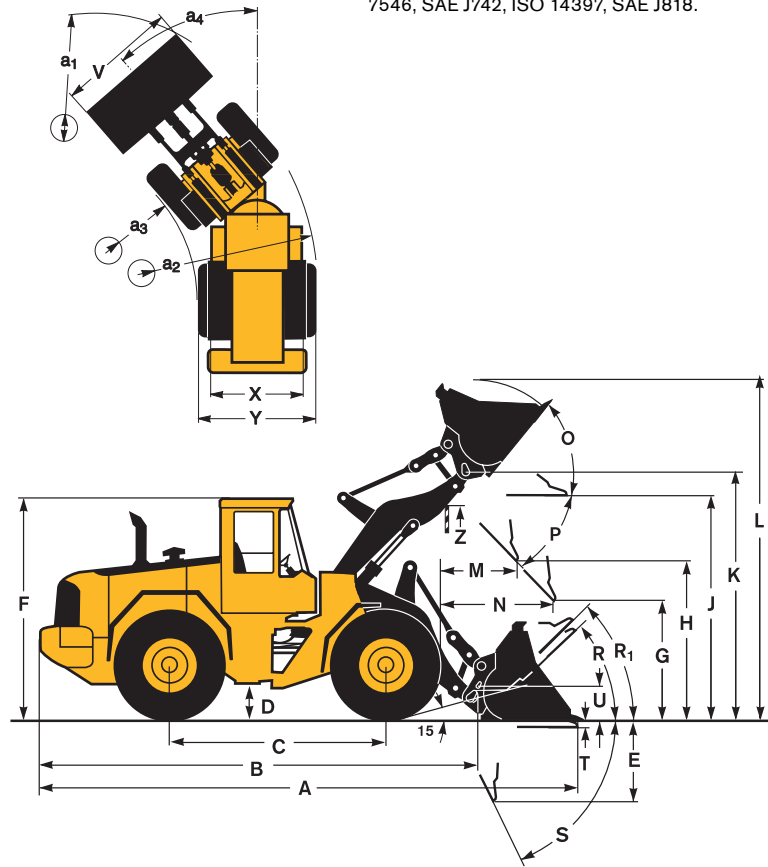





Where applicable, specifications and dimensions are in accordance with ISO 7131, SAE J732, ISO 7546, SAE J742, ISO 14397, SAE J818.



Supplemental Operating Data

Tires 29.5 R25 L4	Standard Boom						Long Boom							
	29.5 R25 L3		29.5 R25 L5		875/65 R29		29.5 R25 L3		29.5 R25 L5		875/65 R29			
Width over tires	mm	in	-20	-0.8	+35	+1.4	+95	+3.7	-20	-0.8	+35	+1.4	+95	+3.7
Ground clearance	mm	in	-20	-0.8	+35	+1.4	-25	-1.0	-20	-0.8	+35	+1.4	-25	-1.0
Tipping load, full turn	kg	lb	-240	-530	+855	+1,880	+65	+140	-230	-510	+780	+1,720	+70	+150
Operating weight	kg	lb	-445	-980	+1130	+2,490	+290	+640	-445	-980	+1130	+2,490	+290	+640

Tires 29.5 R25 L4	GENERAL PURPOSE					ROCK*		LIGHT MATERIAL		LONG BOOM
										
	Bolt-on edges	Bolt-on edges	Bolt-on edges	Teeth & Segments	Teeth & Segments	Teeth & Segments	Teeth & Segments	Bolt-on edges	Bolt-on edges	
Volume, heaped ISO/SAE	m ³ 7.3	5,6 5,4 7.1	5,2 5,2 6.8	5,2 5,2 6.8	4,9 4,9 6.4	4,5 4,5 5.9	4,5 4,5 5.9	8,2 10,7 12.4	9,5 12,4 13.7	—
Volume at 110% fill factor	m ³ 8.1	6,2 7,7 8.1	5,9 5,7 7.5	5,7 5,7 7.5	5,4 5,4 7.1	—	—	9,0 11,8 13.7	10,5 13,7 15.2	—
Static tipping load, straight	kg 51,790	23 490 23 650 52,140	23 630 23 630 52,100	23 500 23 500 51,810	23 600 23 600 52,030	23 920 23 920 52,730	24 420 24 420 53,840	22 490 22 490 49,580	22 950 22 950 50,600	-2820 -6,217
at 35° turn	kg 46,010	20 870 21 030 46,360	21 020 21 020 46,340	20 890 20 890 46,050	20 990 20 990 46,280	21 260 21 260 46,870	21 750 21 750 47,950	19 930 19 930 43,940	20 390 20 390 44,950	-2580 -5,688
at full turn	kg 45,350	20 570 20 740 45,720	20 730 20 730 45,700	20 590 20 590 45,390	20 690 20 690 45,610	20 960 20 960 46,210	21 440 21 440 47,270	19 640 19 640 43,300	20 100 20 100 44,310	-2550 -5,622
***Operating Load	kg 17,550	7960 7800 17,200	7860 7860 17,330	6390 6390 14,080	7790 7790 17,170	8260 8260 18,200	7400 7400 16,310	6620 6620 14,590	6240 6240 13,760	—
Maximum Material Density (100% Fill Factor)	kg/cm 2,400	1430 1440 2,420	1510 1510 2,550	1230 1230 2,070	1590 1590 2,680	1830 1830 3,080	1640 1640 2,760	810 810 1,360	660 660 1,110	—
Breakout force	kN 49,080	218,3 222,9 50,110	222,9 222,9 50,110	223,2 223,2 50,180	229,7 229,7 51,640	191,4 191,4 43,030	239,2 239,2 53,770	171,3 171,3 38,510	166,8 166,8 37,500	—
A	mm 29'11"	9120 9080 29'9"	9080 9080 29'9"	9300 9300 30'6"	9250 9250 30'4"	9570 9570 31'5"	9200 9200 30'2"	9450 9450 31'0"	9600 9600 31'6"	+320 +1'1"
E	mm 4'5"	1340 1310 4'4"	1310 1310 4'4"	1500 1500 4'11"	1450 1450 4'9"	1730 1730 5'8"	1410 1410 4'8"	1710 1710 5'7"	1750 1750 5'9"	-20 -0'1"
H*)	mm 10'9"	3270 3290 10'10"	3290 3290 10'10"	3150 3150 10'4"	3180 3180 10'5"	3040 3040 10'0"	3210 3210 10'6"	2960 2960 9'9"	2920 2920 9'7"	+360 +1'2"
L	mm 21'6"	6550 6510 21'4"	6470 6470 21'3"	6470 6470 21'3"	6410 6410 21'0"	6420 6420 21'1"	6480 6480 21'3"	6490 6490 21'3"	6580 6580 21'7"	+360 +1'2"
M*)	mm 4'2"	1280 1250 4'1"	1250 1250 4'1"	1400 1400 4'7"	1370 1370 4'6"	1700 1700 5'7"	1330 1330 4'4"	1570 1570 5'2"	1600 1600 5'3"	-30 -0'1.2"
N*)	mm 6'8"	2030 2020 6'8"	2020 2020 6'8"	2110 2110 6'11"	2090 2090 6'10"	2230 2230 7'4"	2060 2060 6'9"	2150 2150 7'1"	2160 2160 7'1"	+270 0'11"
V	mm 11'2"	3400 3400 11'2"	3400 3400 11'2"	3430 3430 11'3"	3430 3430 11'3"	3430 3430 11'3"	3430 3430 11'3"	3700 3700 12'2"	3700 3700 12'2"	—
a, clearance circle	mm 50'10"	15 500 15 490 50'9"	15 490 15 490 50'9"	15 620 15 620 51'3"	15 600 15 600 51'2"	15 760 15 760 51'8"	15 570 15 570 51'1"	16 000 16 000 52'6"	16 030 16 030 52'7"	—
Operating weight	kg 69,230	31 400 31 260 68,920	31 180 31 180 68,740	31 280 31 280 68,960	31 190 31 190 68,760	32 660 32 660 72,000	32 450 32 450 71,540	31 660 31 660 69,800	31 190 31 190 68,760	+210 +460

*) With L5 tires

Note: This only applies to Volvo original attachments.





**) Measured to the tip of the bucket teeth or bolt-on edge. Dump height to bucket edge. Measured at 45° dump angle. (Spade nose buckets at 42°.)

***) Rated at Volvo's recommended maximum utilization for L220E.

Bucket Selection Chart

The chosen bucket is determined by the density of the material and the expected bucket fill factor. The actual bucket volume is often larger than the rated capacity, due to the features of the TP Linkage, including an open bucket design, good rollback angles in all positions and good bucket filling performance. The example represents a standard boom configuration.

Example: Sand and gravel. Fill factor ~ 105%. Density 2,780 lb/yd³. Result: The 6.0 yd³ bucket carries 6.3 yd³. For optimum stability, always consult the bucket selection chart.

Material	Bucket fill, %		Material density,		ISO/SAE bucket volume,		Actual volume,	
			t/m ³	lb/yd ³	m ³	yd ³	m ³	yd ³
Earth/Clay	~ 110		~ 1,65	~ 2,780	4,9	6.4	~ 5,4	~ 7.1
			~ 1,55	~ 2,610	5,2	6.8	~ 5,7	~ 7.5
			~ 1,45	~ 2,445	5,4	7.1	~ 5,9	~ 7.7
Sand/Gravel	~ 105		~ 1,75	~ 2,950	4,9	6.4	~ 5,1	~ 6.7
			~ 1,65	~ 2,780	5,2	6.8	~ 5,5	~ 7.2
			~ 1,55	~ 2,610	5,4	7.1	~ 5,7	~ 7.5
Aggregate	~ 100		~ 1,80	~ 3,035	4,9	6.4	~ 4,9	~ 6.4
			~ 1,70	~ 2,865	5,2	6.8	~ 5,2	~ 6.8
			~ 1,65	~ 2,780	5,4	7.1	~ 5,4	~ 7.1
Rock	≤ 100		~ 1,70	~ 2,865	4,5	5.9	~ 4,5	~ 5.9

The size of rock buckets is optimized for optimal penetration and filling capability rather than the density of the material.

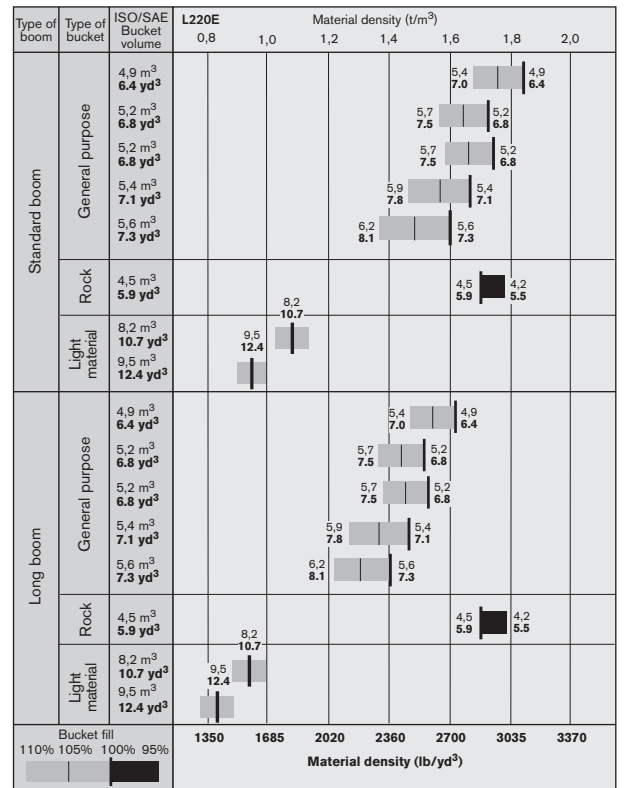

STANDARD EQUIPMENT

Service and maintenance

Toolbox, lockable

Engine

Three-stage air cleaner with ejector and inner filter
Indicator glass for coolant level
Preheating of induction air
Two fuel filters
Fuel fill strainer
Coolant filter
Oil trap

Electrical system

24 V, prewired for optional accessories
Alternator, 24 V/55 A
Air filter for alternator
Battery disconnect switch
Fuel gauge
Hour meter
Electric horn
Reverse alarm
Instrument panel with symbols
Lighting:

- Twin halogen front headlights with high and low beams
- Parking lights
- Double brake and tail lights
- Turn signals with flashing hazard light function
- Halogen working lights (2 front and 2 rear)
- Instrument lighting

Conronic monitoring system

ECU with log and analysis system
Conronic display
Fuel consumption
Ambient temperature
Engine shutdown to idle in case of malfunction indication:

- High engine coolant temperature
- Low engine oil pressure
- High transmission oil temperature

Start interlock when gear is engaged
Brake test
Test function for warning and indicator lights
Warning and indicator lights:

- Charging
- Oil pressure engine
- Oil pressure transmission
- Brake pressure
- Parking brake

- Hydraulic oil level
 - Axle oil temperature
 - Primary steering
 - Secondary steering
 - High beams
 - Turn signals
 - Rotating beacon
 - Preheating coil
 - Differential lock
 - Coolant temperature
 - Transmission oil temperature
 - Brake charging
- Level warnings:
- Engine oil level
 - Coolant level
 - Transmission oil level
 - Hydraulic oil level
 - Washer fluid level

Drivetrain

Automatic Power Shift with operator-controlled declutch function for transmission cut-out when braking and mode selector with AUTO function
Fully automatic shifting gears 1-4
PWM-control between different gear positions
Forward and reverse switch by lever console
Differentials:

- front: 100% hydraulic diff. lock
- rear: conventional

Tires

29.5 R25

Brake system

Wet oil circulation cooled disc brakes on all four wheels
Dual brake circuits
Dual service brake pedals
Secondary brake system
Parking brake, el.-hydraulic
Brake wear indicator

Cab

ROPS (ISO 3471), FOPS (ISO 3449)
Lock kit, one combination
Acoustic inner lining
Ashtray
Cigarette lighter
Lockable door
Cab heating with filter, fresh-air inlet and defroster
Floor mat

Interior light
Interior rearview mirror
Two exterior rearview mirrors
Openable window right-hand side
Sliding window, right
Sliding window, door
Tinted safety glass
Hip retractable seatbelt (SAE J386)
Adjustable steering wheel
Adjustable lever console
Operator's seat air suspended with high backrest and electrical heating
Storage compartment
Sun visor
Beverage holder
Windshield washers front and rear
Windshield wipers front and rear
Interval function for front and rear windshield wipers
Service platforms with anti-slip surfaces on front and rear fenders
Speedometer
Air conditioning with corrosion prot. condenser

Hydraulic system

Main valve, 2-spool
Pilot valve, 2-spool
Variable displacement axial piston pumps (3) for:

- working hydraulics
- steering system, pilot hydraulics and brakes
- fan motor

Boom lowering system
Boom kickout, automatic, adjustable
Bucket positioner, automatic with position indicator, adjustable
Hydraulic oil cooler
Hydraulic oil cooler, extra

External equipment

Noise and vibration dampening suspension of cab, engine and transmission
Lifting lugs
Easy-to-open side panels
Frame steering, joint lock
Vandalism lock prepared for batteries and engine compartment
Towing hitch

Other equipment

Decals, USA

OPTIONAL EQUIPMENT

(Standard in certain markets)

Service and maintenance

Tool kit
Automatic lubrication system
Automatic lubrication system inclusive long boom
Automatic lubrication system for attachment bracket, welded
Refill pump for automatic lubrication system
Wheel nut wrench kit
Grease nipple guards
Oil sampling valve

Engine equipment

Engine block heater, 120 V
Engine block heater, 230 V
Air pre-cleaner, oil-bath type
Air pre-cleaner, turbo type
Air pre-cleaner, Sy-Klone type
Hand throttle control
Fuel filter, extra large with water trap
Fuel filter, with water trap and heating
Radiator, corrosion protected
Fan air intake protection
Reversible cooling fan
Reversible cooling fan in combination with axle oil cooler

Electrical system

Alternator, 80 A
Working light, attachments
Working lights front, extra
Working lights rear, extra
Working lights front, on cab, dual
Working lights front, high intensity
Assymetrical lights for left-hand traffic
Reverse light
Shortened headlight support brackets
Warning beacon, flashing strobe light
Warning beacon, rotating, collapsible
Battery disconnect switch, additional in cab
Fire suppression system

Cab

Installation kit for radio
Radio with tape recorder

Radio with CD-player
Sun blinds, front and rear windows
Sun blinds, side windows
Retractable hipbelt, longer and wider than standard
Air-conditioning with corrosion prot. condenser and automatic temp. control (ATC)
Ventilation air filter for work in asbestos environment
Operator's seat with low backrest
Operator's seat with low backrest and electrical heating
Operator's seat with high backrest and electrical heating
Instructor's seat
Armrest (left) for operator seat
Steering wheel knob
Noise reduction kit
Rearview camera incl. monitor
Rearview mirrors, el. heated
Cab ladder, rubber suspended

Drivetrain

Limited slip rear
Limited slip front and rear
Speed limiter 20 km/h
Speed limiter 30 km/h
Wheel/axle seal guards

Brake system

Oil cooler for front and rear axle
Oil cooler for front and rear axle in comb. with reversible fan

Hydraulic system

Single lever control
Single lever control for 3rd hydraulic function
3rd hydraulic function
3rd hydraulic function for long boom
3rd-4th hydraulic function
Boom Suspension System
Biodegradable hydraulic fluid
Attachment bracket, welded
Artic kit, attachment locking hoses and 3rd hydraulic function
Artic kit, pilot hoses and brake accum. incl. hydraulic oil
Separate attachment locking, standard boom
Separate attachment locking, long boom
Return-to-dig
Hydraulic oil cooler, extra, in combination with axle oil cooler

External equipment

Long boom
Mudguards widener front/rear
Mudguards, fixed front and swing out rear
Deleted front mudguards and rear wideners
Logging counterweight

Protective equipment

Guards for front headlights
Guards for taillights
Guards for taillights, heavy-duty
Guards for side and rear windows
Guards for radiator grille
Windshield guard
Bellyguard front
Bellyguard rear
Bellyguard, oil pan
Cover plate front frame, heavy-duty
Cover plate, under cab
Guards for steer cylinder
Guards for boom cylinder hose and tube
Corrosion protection, painting of machine

Other equipment

Comfort Drive Control, CDC
Secondary steering
CE-marking
Noise reduction kit, exterior

Tires

875/65 R29

Attachments

Buckets:

- Straight with/without teeth
- Spade nose with/without teeth
- High tipping
- Light materials

Bolt-on and weld-on bucket teeth
Cutting edge in three sections, bolt-on
Fork equipment
Material handling arm
Log grapples

Boom Suspension System (BSS)*

BSS utilizes gas/oil accumulators connected to the lift cylinders to absorb shocks and smooth out rough roads for faster cycle times, less spillage and increased operator comfort.



Automatic Lubrication System*

Our factory-fitted Automatic Lubrication System takes care of greasing while the machine is in operation. This means less downtime for scheduled maintenance and more time for productive work.



Comfort Drive Control (CDC)*

CDC significantly reduces repetitive and tiring steering wheel movements. The operator can shift and steer easily with the aid of controls integrated in the left armrest.



3rd and 4th hydraulic functions*

Volvo wheel loaders can be equipped with third and fourth hydraulic functions, which are operated with additional control levers. These functions are necessary when there's a need to operate a third and fourth hydraulic function at the same time, such as when using a timber grapple with hydraulic heel kick-out.

Genuine Volvo attachments

Volvo offers a wide range of bucket wear parts, including the new Volvo Tooth System. Volvo genuine wear parts are designed for all types of applications, from handling easily broken bank materials to breaking out hard and rocky materials, such as shot rock.

* Optional equipment.



Spade nose rock bucket with teeth



Standard bucket with teeth



Standard bucket with edge savers



Timber grapple/Sorting grapple



Volvo Construction Equipment is different. It's designed, built and supported in a different way. That difference comes from our 170-year engineering heritage. A heritage of thinking first about the people who actually use the machines. About how to help them be safer, more comfortable, more productive. About the environment we all share. The result of that thinking is a growing range of machines and a global support network dedicated to helping you do more. People around the world are proud to use Volvo. And we're proud of what makes Volvo different – **More care. Built In.**



All products are not available in all markets. Under our policy of continuous improvement, we reserve the right to change specifications and design without prior notice. The illustrations do not necessarily show the standard version of the machine.

VOLVO

**Volvo Construction Equipment
North America, Inc.**

One Volvo Drive, Asheville, NC 28803-3447
www.volvoce.com

Ref. No. 22 A 100 1566
Printed in USA 02/05 – 5,0
Volvo, Asheville

English
GMC