

# VOLVO WHEEL LOADER

# L180C

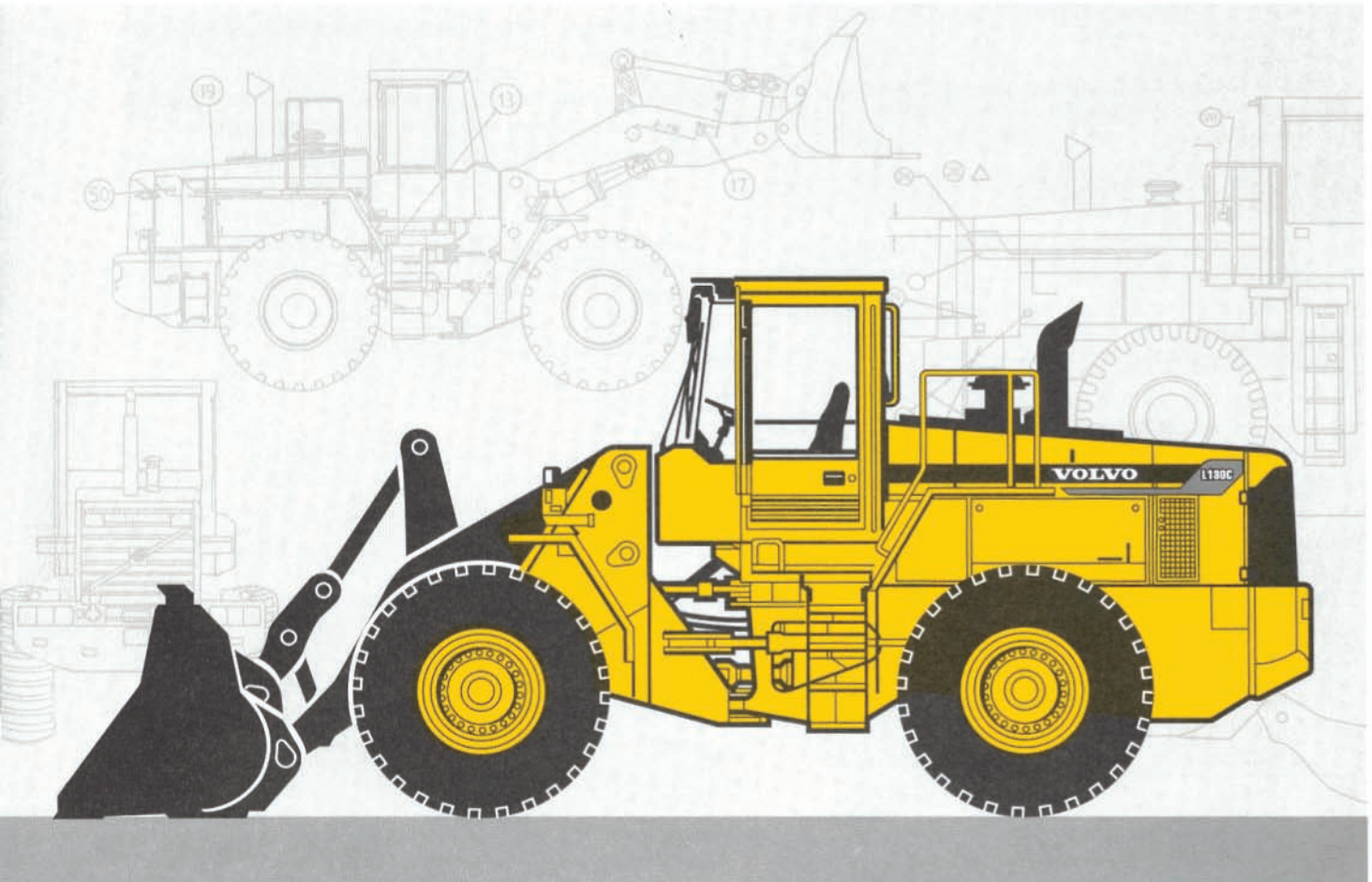

- **Engine output SAE J1349:**  
gross 209 kW 284 hp  
net 198 kW 269 hp
  - **Operating weight:** 24,9-28,2 t  
54,890 - 62,170 lb
  - **Buckets:** 4,2 - 14,0 m<sup>3</sup>  
5.5 - 18.3 yd<sup>3</sup>
  - **Volvo high-performance, low-emission engine** with excellent low rpm performance. The engine meets all known regulations regarding exhaust emissions for off-road machines until year 2001. Hydraulically driven, cooling fan.
  - **Volvo transmission with APS II**, 2nd generation of Automatic Power Shift with mode (shift pattern) selector for optimum performance and fuel consumption
  - **Wet disc brakes**  
– fully sealed oil circulation-cooled wet disc brakes
  - **Torque Parallel Linkage**  
– high breakout torque throughout the working range  
– excellent parallel lift-arm action
  - **Care Cab**  
– pressurized cab with high comfort and safety
  - **Contronic** monitoring system
  - **Load sensing steering system**
  - **Pilot-operated working hydraulics**
- Optional Equipment**
- Boom Suspension System
  - Comfort Drive Control
  - Long Boom
  - Hydraulic attachment bracket
- Other options, see back page**

## VOLVO



## SERVICE

Contronic monitoring system provides information on machine condition, routine maintenance schedules and minimizes time required for troubleshooting.

**Service accessibility:** Large, easy-to-open engine access doors with gas struts. Hinged radiator grill, swing-out radiator, and swing-out fan.

| Refill capacities     | l     | USgal     |
|-----------------------|-------|-----------|
| Fuel tank .....       | 318   | 84.0      |
| Engine coolant .....  | 70    | 18.5      |
| Hydraulic tank .....  | 165   | 43.6      |
| Transmission .....    | 35    | 9.2       |
| Engine oil .....      | 34    | 9.0       |
| Axle front/rear ..... | 55/54 | 14.5/14.3 |



## ENGINE

Engine delivers high torque and quick response at low rpm even under full load. The machine can work at low engine speeds, which contributes to good fuel economy, less noise, less wear and longer life.

**Engine:** High-performance, low-emission, 6-cylinder, in-line, direct-injected, turbocharged, intercooled 4-stroke diesel engine with wet replaceable cylinder liners.

**Air cleaning:** three-stage.

**Cooling system:** Hydraulically driven fan. Twin pump system for the intercooler circuit.

|                       |                  |                     |
|-----------------------|------------------|---------------------|
| Engine .....          | Volvo TD 122 KHE |                     |
| output at .....       | 35 r/s           | 2100 rpm            |
| SAE J1349 gross ..... | 209 kW           | 284 hp              |
| (flywheel) net .....  | 198 kW           | 269 hp              |
| Max. torque at .....  | 15 r/s           | 900 rpm             |
| SAE J1349 gross ..... | 1580 Nm          | 1166 lb ft          |
| (flywheel) net .....  | 1570 Nm          | 1159 lb ft          |
| Displacement .....    | 12,0 l           | 733 in <sup>3</sup> |

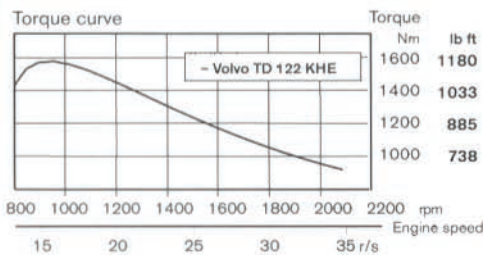

## ELECTRICAL SYSTEM

Contronic monitoring system with complete information on the status of the machine's various systems is standard. Electrical system with circuit board is well protected by fuses. Prewired for optional equipment.

**Central warning:** Central warning lamp for the following functions: engine oil pressure, engine coolant temperature (with buzzer), transmission oil pressure, transmission oil temperature, brake pressure, parking brake (buzzer), high speed/gear, transmission oil filter, and axle oil temperature. Shut down to idle is standard.

|                                  |               |
|----------------------------------|---------------|
| Voltage .....                    | 24 V          |
| Batteries .....                  | 2x12 V        |
| Battery capacity .....           | 2x160 Ah      |
| Cold cranking capacity, ea ..... | 1050 A        |
| Reserve capacity, ea .....       | 290 min       |
| Alternator rating .....          | 1680 W / 60 A |
| Starter-motor output .....       | 6,6 kW 9.0 hp |



## DRIVETRAIN

Drivetrain and working hydraulics well-matched to each other. Dependable design. Quick acceleration boosts productivity. Volvo system-compatible design facilitates servicing.

**Torque converter:** Single-stage.

**Transmission:** Volvo Automatic Power Shift transmission of countershaft type with single-lever control. Fast and smooth forward/reverse shifting.

**Shifting system:** Volvo Automatic Power Shift (APS II) with mode selector.

**Axles:** Volvo, fully floating axle shafts with planetary-type hub reductions. Cast-steel axle housing. Fixed front axle and oscillating rear axle. 100% differential lock on front axle.

|                              |              |      |
|------------------------------|--------------|------|
| Transmission .....           | Volvo HT 220 |      |
| Torque multiplication .....  | 2,27:1       |      |
| Speeds, max. forward/reverse | km/h         | mph  |
| 1 .....                      | 6,5          | 4.0  |
| 2 .....                      | 12,1         | 7.5  |
| 3 .....                      | 24,0         | 14.9 |
| 4 (forward only) .....       | 35,1         | 21.8 |

|                                |                |       |
|--------------------------------|----------------|-------|
| Measured with tires .....      | 26.5 R25** L3  |       |
| Front axle and rear axle ..... | Volvo / AWB 40 |       |
| Oscillation, rear axle .....   | ±15 °          |       |
| Ground clearance at            |                |       |
| 15° oscillation .....          | 610 mm         | 24 in |



## BRAKE SYSTEM

Simple, reliable system with few parts ensures high availability and safety. Self-adjusting internal oil circulation-cooled disc brakes give long service intervals.

**Service brakes:** Volvo, dual-circuit system with nitrogen-charged accumulators. Fully hydraulically operated, enclosed, internal oil circulation-cooled, outboard-mounted disc brakes. Transmission declutch during braking can be preselected by a switch on the instrument panel.

**Parking brake:** Enclosed wet multi-disc brake built into the transmission. Spring applied, electro-hydraulic released via a switch on the instrument panel. Applies automatically when the key is turned off.

**Secondary brake:** Dual-circuit system with rechargeable accumulators. One circuit or the parking brake fulfills the requirements.

Brake performance test provided by the Contronic system.

**Standards:** The brake system complies with the requirements of ISO 3450, SAE J1473

|                                 |                                |
|---------------------------------|--------------------------------|
| Number of discs/wheel .....     | 1                              |
| Accumulators, volume each ..... | 3x1,0 l 3x61.0 in <sup>3</sup> |



## STEERING SYSTEM

Low-effort steering gives short work cycle times. Power-efficient system provides good fuel economy, good directional stability and easy steering in all conditions.

**Steering system:** Load-sensing hydrostatic articulated steering with power amplification.

**System supply:** The steering system is supplied by a separate steering pump.

**Pump:** Variable-flow axial piston pump.

**Cylinders:** Two double-acting cylinders.

|                           |           |            |
|---------------------------|-----------|------------|
| Steering cylinder .....   | 2         |            |
| Bore .....                | 100 mm    | 3.9 in     |
| Piston rod diameter ..... | 50 mm     | 2.0 in     |
| Stroke .....              | 418 mm    | 16.5 in    |
| Relief pressure .....     | 21 MPa    | 3046 psi   |
| Max. flow .....           | 116 l/min | 30.6 USgpm |
| Articulation .....        | ± 37°     |            |



## CAB

Care Cab with easy entry and wide door opening. Lined with sound-absorbent material. Sound and vibration-suppressing suspension. Good all-round visibility, large glass areas. Curved windshield of laminated, green-tinted glass. Ergonomically located controls and instruments permit a comfortable operating position.

**Instrumentation:** All important information is readily visible to the operator. Cab display for Contronic monitoring system.

**Heater and defroster:** Heating element with filtered fresh air and four-speed fan. Defroster outlets for all windows.

**Operator's seat:** Spring suspended, adjustable operator's seat with retractable seat belt. The seat is mounted on a bracket on the rear wall. The force from the belt is absorbed by the seat rails.

**Standards:** Tested and approved according to the following standards: ROPS (ISO/CD 3471, SAE J1040), FOPS (ISO 3449, SAE J231). Complies with "Overhead guards for rider lift trucks" (ISO 6055) and "Operator Restraint System" (SAE J386).

|  |                        |                          |
|--|------------------------|--------------------------|
| Emergency exits .....                                    | 2                      |                          |
| Sound level in cab<br>as per ISO 6394,<br>SAE J919 ..... | 75 dB (A)              |                          |
| Fan position 2 .....                                     | 73 dB (A)              |                          |
| Exterior sound level<br>ISO 6393, SAE J2104 .....        | LwA 110 dB (A)         |                          |
| Ventilation .....  | 10 m <sup>3</sup> /min | 353 ft <sup>3</sup> /min |
| Heating capacity .....                                   | 11 kW                  | 37 500 Btu/h             |
| Air-conditioning (optional) .....                        | 8 kW                   | 27 300 Btu/h             |



## HYDRAULIC SYSTEM

Open-center hydraulics with high-capacity vane pumps allows precise control and quick movements, even at low rpm.

**Pump:** A double vane pump mounted on a power takeoff on the transmission. Pump 1 works with all tilt and lift movements. Pump 2 works with tilt out and lift up to 20 MPa (2900 psi). A pilot-controlled selector valve cuts-in flow to the system.

**Valve:** Double-acting 3-spool valve actuated by a 3-spool pilot valve.

**Lift function:** The valve has four functions: raise, hold, lower and float. Inductive/magnetic automatic boom kickout can be switched on and off and is adjustable to any position between maximum reach and full lift height.

**Tilt function:** The valve has three functions: rollback, hold and dump. Inductive/magnetic automatic bucket positioner, that can be switched on and off.

**Cylinders:** Double-acting

**Filter:** Full-flow filtration through 20 micron (absolute) filter cartridge.

|                               |             |             |
|-------------------------------|-------------|-------------|
| Vane pump                     |             |             |
| Relief pressure, pump 1 ..... | 22,5 MPa    | 3363 psi    |
| Flow .....                    | 313 l/min   | 82.8 USgpm  |
| at .....                      | 10 MPa      | 1450 psi    |
| and engine speed .....        | 35 r/s      | 2100 rpm    |
| Relief pressure, pump 2 ..... | 20 MPa      | 2900 psi    |
| Flow .....                    | 91,5 l/min  | 24.2 USgpm  |
| at .....                      | 10 MPa      | 1450 psi    |
| and engine speed .....        | 35 r/s      | 2100 rpm    |
| Pilot system                  |             |             |
| Relief pressure               | 3,0-4,5 MPa | 435-653 psi |
| Cycle times                   | s           |             |
| Raise* .....                  | 6,6         |             |
| Dump* .....                   | 2,5         |             |
| Lower, empty .....            | 3,5         |             |
| Total cycle time .....        | 12,6        |             |

\* with load as per ISO 5998 and SAE J818













## LIFT ARM SYSTEM

TP Linkage combines high breakout torque throughout the working range with parallel lift-arm action. These features, together with high lift height and long reach, make the lift-arm system equally good in bucket loading and work with fork attachments and material-handling arms.

|                           |        |         |
|---------------------------|--------|---------|
| Lift cylinder .....       | 2      |         |
| Bore .....                | 190 mm | 7.5 in  |
| Piston rod diameter ..... | 90 mm  | 3.5 in  |
| Stroke .....              | 788 mm | 31.0 in |
| Tilt cylinder .....       | 1      |         |
| Bore .....                | 260 mm | 10.2 in |
| Piston rod diameter ..... | 120 mm | 4.7 in  |
| Stroke .....              | 480 mm | 18.9 in |

# OPERATIONAL DATA VOLVO L180C

|                                 |                 | STANDARD BOOM   |   |   |   |   |  |   | LONG BOOM   |   |   |
|---------------------------------|-----------------|---|---|---|---|---|--|---|---|---|---|
|                                 |                 | GENERAL PURPOSE   |   |   |   |   | ROCK*  | LIGHT MTL.  | GEN. PUR.   | LIGHT MTL.  |   |
|                                 |                 |  |  |  |  |  |  |  |  |  |  |
| Tires 26.5 R25** L3             |                 | Bolt-on edges   | Bolt-on edges   | Teeth   | Teeth & Segm.   | Teeth   | Bolt-on edges  | Teeth & Segm.   | Bolt-on edges   | Bolt-on edges   | Bolt-on edges   |
| Volume, heaped                  | m <sup>3</sup>  | 4,8   | 4,8   | 4,4   | 4,4   | 4,2   | 4,6  | 4,2   | 7,8   | 3,7   | 6,8   |
| ISO/SAE                         | yd <sup>3</sup> | 6,3   | 6,3   | 5,8   | 5,8   | 5,5   | 6,0  | 5,5   | 10,2  | 4,8   | 8,9   |
| Volume at 110% fill factor      | m <sup>3</sup>  | 5,3   | 5,3   | 4,8   | 4,8   | 4,6   | 5,1  | -   | -   | 4,1   | -   |
|                                 | yd <sup>3</sup> | 6,9   | 6,9   | 6,3   | 6,3   | 6,0   | 6,6  | -   | -   | 5,3   | -   |
| Static tipping load, straight   | kg              | 19820   | 19100   | 20330   | 19860   | 20350   | 20040  | 20720   | 19420   | 20770   | 19900   |
|                                 | lb              | 43,700  | 42,110  | 44,830  | 43,780  | 44,870  | 44,180   | 45,680  | 42,800  | 45,790  | 43,870  |
| at 35° turn                     | kg              | 17430   | 16750   | 17930   | 17480   | 17970   | 17560  | 18290   | 17080   | 18430   | 17570   |
|                                 | lb              | 38,430  | 36,920  | 39,540  | 38,530  | 39,610  | 38,900   | 40,320  | 37,660  | 40,630  | 38,730  |
| at full turn                    | kg              | 17150   | 16470   | 17650   | 17200   | 17690   | 17370  | 18010   | 16810   | 18160   | 17300   |
|                                 | lb              | 37,810  | 36,310  | 38,920  | 37,920  | 39,000  | 38,280   | 39,700  | 37,060  | 40,035  | 38,140  |
| Breakout force                  | kN              | 192,9   | 182,3   | 211,5   | 201,2   | 211,5   | 201,1  | 181,6   | 145,7   | 218,0   | 153,2   |
|                                 | lbf             | 43,360  | 40,980  | 47,550  | 45,230  | 47,550  | 45,210   | 40,690  | 32,750  | 49,010  | 34,440  |
| A                               | mm              | 8550  | 8640  | 8690  | 8720  | 8690  | 8480   | 8850  | 9030  | 8350  | 8950  |
|                                 | ft in           | 28'1"   | 28'4"   | 28'6"   | 28'7"   | 28'6"   | 27'10"   | 29'0"   | 29'7"   | 27'4"   | 29'3"   |
| E                               | mm              | 1420  | 1500  | 1270  | 1360  | 1270  | 1360   | 1470  | 1860  | 1240  | 16790   |
|                                 | ft in           | 4'8"  | 4'11"   | 4'2"  | 4'5"  | 4'2"  | 4'5"   | 4'10"   | 6'1"  | 4'4"  | 5'10"   |
| H**)                            | mm              | 3070  | 3010  | 2990  | 2960  | 2990  | 3120   | 2890  | 2700  | 3200  | 2770  |
|                                 | ft in           | 10'1"   | 9'11"   | 9'10"   | 9'8"  | 9'10"   | 10'3"  | 9'6"  | 8'10"   | 10'5"   | 9'5"  |
| L                               | mm              | 6180  | 6230  | 6170  | 6130  | 6130  | 6170   | 6230  | 6300  | 5950  | 6230  |
|                                 | ft in           | 20'3"   | 20'5"   | 20'3"   | 20'1"   | 20'1"   | 20'3"  | 20'9"   | 20'8"   | 19'5"   | 20'2"   |
| M**)                            | mm              | 1330  | 1390  | 1480  | 1460  | 1480  | 1280   | 1560  | 1620  | 1200  | 1580  |
|                                 | ft in           | 4'4"  | 4'7"  | 4'10"   | 4'9"  | 4'10"   | 4'2"   | 5'1"  | 5'4"  | 3'9"  | 5'2"  |
| N**)                            | mm              | 1960  | 2000  | 2080  | 2040  | 2080  | 1930   | 2110  | 2060  | 1880  | 2060  |
|                                 | ft in           | 6'5"  | 6'7"  | 6'10"   | 6'8"  | 6'10"   | 6'4"   | 6'11"   | 6'9"  | 6'2"  | 6'8"  |
| V                               | mm              | 3200  | 3200  | 3230  | 3230  | 3230  | 3200   | 3230  | 3400  | 3200  | 3200  |
|                                 | ft in           | 10'6"   | 10'6"   | 10'7"   | 10'7"   | 10'7"   | 10'6"  | 10'7"   | 11'2"   | 10'6"   | 10'6"   |
| a <sub>1</sub> clearance circle | mm              | 14980   | 15030   | 15150   | 15150   | 15150   | 14940  | 15230   | 15430   | 14870   | 15200   |
|                                 | ft in           | 49'2"   | 49'4"   | 49'9"   | 49'9"   | 49'9"   | 49'0"  | 50'0"   | 50'8"   | 48'8"   | 49'9"   |
| Operating weight                | kg              | 26020   | 26330   | 25910   | 26080   | 25860   | 25970  | 27390   | 26020   | 25540   | 25880   |
|                                 | lb              | 57,370  | 58,040  | 57,120  | 57,490  | 57,020  | 52,260   | 60,390  | 57,350  | 56,300  | 57,050  |

\*) with L5 tires  
\*\*) at dump angle 45°

Including counterweight 1

## Bucket selection chart

The choice of bucket is determined by the density of the material and the bucket fill factor. The TP-linkage uses a more open bucket design, has very good rollback in all positions and fills the bucket very well. This means that the actual volume carried is often larger than the rated capacity of the bucket. Bucket fill factor in different materials and how they affect the actual bucket volume are shown below. **Example: Sand and gravel. Fill factor ~105%. Density 2870 lb/yd<sup>3</sup>. Result: The 4,2 m<sup>3</sup>/5,5 yd<sup>3</sup> bucket carries 4,4 m<sup>3</sup>/5,8 yd<sup>3</sup>. For optimum stability always consult the bucket selection chart.**

| Material    | Bucket fill, % | Material density, ton/m <sup>3</sup> |                    | ISO/SAE bucket volume, m <sup>3</sup> yd <sup>3</sup> |                 | Actual volume, m <sup>3</sup> yd <sup>3</sup> |                 |
|-------------|----------------|--------------------------------------|--------------------|---|-----------------|---|-----------------|
|             |                | lb/ft <sup>3</sup>                   | lb/yd <sup>3</sup> | m <sup>3</sup>  | yd <sup>3</sup> | m <sup>3</sup>                                | yd <sup>3</sup> |
| Earth/Clay  | 110            | 1,60                                 | 2700               | 4,2   | 5,5             | 4,6   | 6,0             |
|             |                | 1,55                                 | 2620               | 4,4   | 5,8             | 4,8   | 6,3             |
|             |                | 1,45                                 | 2450               | 4,6   | 6,0             | 5,1   | 6,6             |
| Sand/Gravel | 105            | 1,70                                 | 2870               | 4,2   | 5,5             | 4,4   | 5,8             |
|             |                | 1,60                                 | 2700               | 4,4   | 5,8             | 4,6   | 6,0             |
|             |                | 1,50                                 | 2535               | 4,6   | 6,0             | 4,8   | 6,3             |
| Aggregate   | 100            | 1,80                                 | 3040               | 4,2   | 5,5             | 4,2   | 5,5             |
|             |                | 1,70                                 | 2870               | 4,4   | 5,8             | 4,4   | 5,8             |
|             |                | 1,60                                 | 2700               | 4,6   | 6,0             | 4,6   | 6,0             |
| Rock        | ≤100           | 1,70                                 | 2870               | 4,2   | 5,5             | 4,2   | 5,6             |

The size of rock buckets is optimized for penetration and filling capability rather than the density of the material.

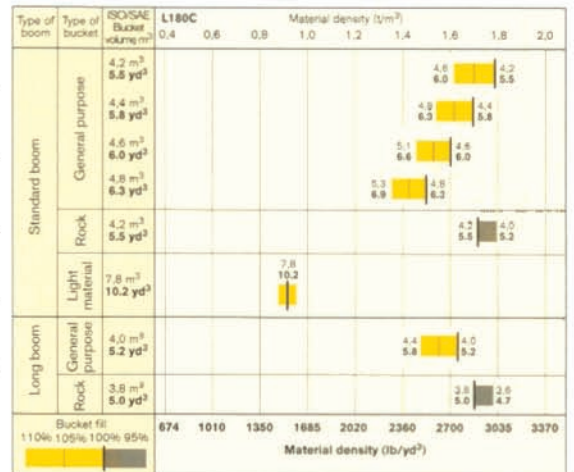

## Supplemental operating data

|                         |       | Standard Boom |       |            |       | Long Boom |       |            |       |      |       |
|-------------------------|-------|---------------|-------|------------|-------|-----------|-------|------------|-------|------|-------|
|                         |       | 26.5 R25*     |       | 30/65 R29* |       | 26.5 R25* |       | 30/65 R29* |       | Cw 2 |       |
|                         |       | L5            |       | L3         |       | L5        |       | L3         |       |      |       |
| Width over tires        | mm in | +30           | +1'2" | +175       | +6'9" | -         | -     | +30        | +1'2" | +175 | +6'9" |
| Ground clearance        | mm in | +30           | +1'2" | +5         | +0'2" | -         | -     | +30        | +1'2" | +5   | +0'2" |
| Tipping load, full turn | kg lb | +900          | +1980 | +510       | +1120 | -900      | -1980 | +1375      | +3020 | +750 | +1650 |
| Operating weight        | kg lb | +980          | +2160 | +600       | +1320 | -470      | -1040 | +720       | +1590 | +980 | +2160 |

Counterweight 1 may be used in rehandling and material-handling. Counterweight 2, and combinations of counterweight 1 and 2, may be used in pallet fork and material-handling arm applications for stabilizing purposes on firm and level ground.

Counterweight 2 replaces hydroinflation of rear tires. Counterweight 2 must never be combined with tire chains. Combinations of L4 and L5 tires and chains are strictly forbidden.

## OPERATIONAL DATA & DIMENSIONS

Tires: 26.5 R25\*\* L3

|                  | Standard Boom    | Long Boom         |
|------------------|------------------|-------------------|
| B                | 6860 mm<br>22'5" | 7290 mm<br>23'11" |
| C                | 3550 mm<br>11'8" | 3550 mm<br>11'8"  |
| D                | 480 mm<br>1'7"   | 480 mm<br>1'7"    |
| F                | 3560 mm<br>11'8" | 3560 mm<br>11'8"  |
| G                | 2135 mm<br>7'0"  | 2135 mm<br>7'0"   |
| J                | 4090 mm<br>13'5" | 4600 mm<br>15'1"  |
| K                | 4480 mm<br>14'8" | 4970 mm<br>16'4"  |
| O                | 57 °             | 55 °              |
| P**              | 45 °             | 45 °              |
| R                | 44 °             | 48 °              |
| R <sub>1</sub> * | 48 °             | 53 °              |
| S                | 71 °             | 63 °              |
| T                | 100 mm<br>3.9"   | 170 mm<br>6.7"    |
| U                | 520 mm<br>1'8"   | 630 mm<br>2'1"    |
| X                | 2280 mm<br>7'6"  | 2280 mm<br>7'6"   |
| Y                | 2950 mm<br>9'8"  | 2950 mm<br>9'8"   |
| Z                | 4030 mm<br>13'3" | 4180 mm<br>13'9"  |
| a <sub>2</sub>   | 6780 mm<br>22'3" | 6780 mm<br>22'3"  |
| a <sub>3</sub>   | 3830 mm<br>12'7" | 3830 mm<br>12'7"  |
| a <sub>4</sub>   | ±37 °            | ±37 °             |

\* Carry position SAE  
\*\* P max 49°

Where applicable, specifications and dimensions are in accordance with ISO 7131, SAE J732, ISO 7546, SAE J742, ISO 5998, SAE J818, ISO 8313.

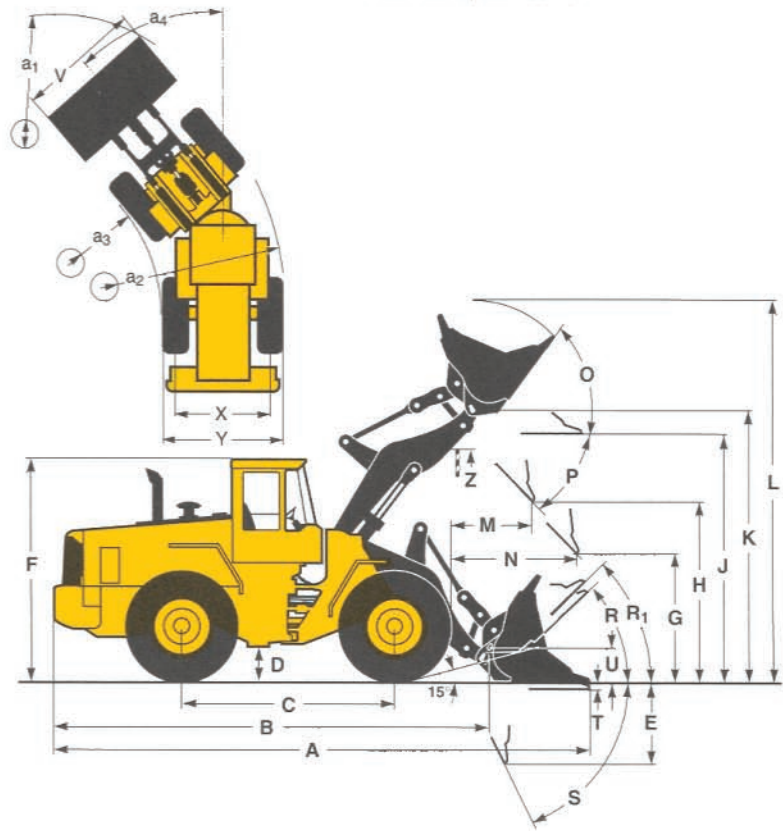

## LOG GRAPPLE (hook on)

Tires: 26.5 R25\*\* L3

|   |  |
|---|--|
| A | 3,5 m <sup>2</sup><br>37,7 ft <sup>2</sup> |
| B | 3780 mm<br>12'5"                           |
| C | 2130 mm<br>7'0"                            |
| D | 3090 mm<br>10'1"                           |
| E | 1620 mm<br>5'6"                            |
| F | 1620 mm<br>5'4"                            |
| G | 3020 mm<br>9'11"                           |
| H | 5120 mm<br>16'9"                           |
| I | 7800 mm<br>25'7"                           |
| J | 3400 mm<br>11'2"                           |
| K | 3650 mm<br>12'0"                           |
| L | 2410 mm<br>7'11"                           |
| M | 9880 mm<br>32'5"                           |

Operating weight: 27000 kg including counterweight 1+2  
59,510 lb  
Operating load: 8800 kg with counterweight 1+2  
19,400 lb

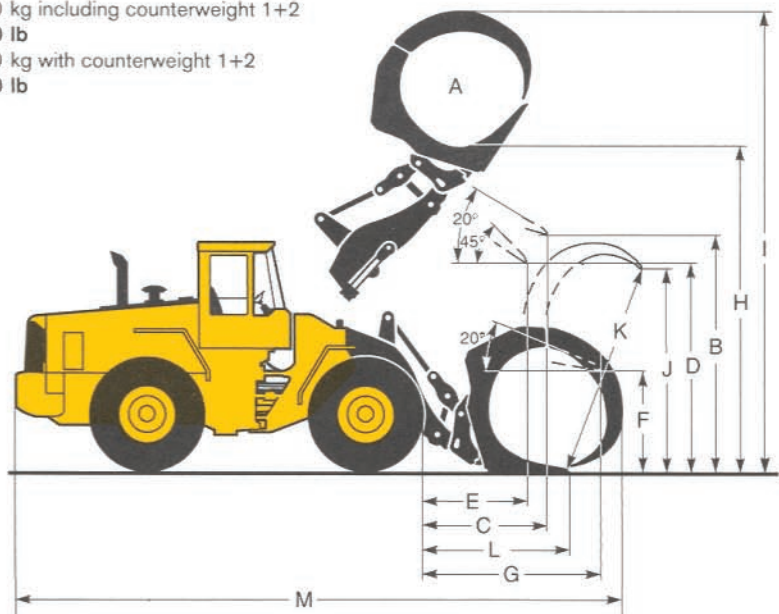

## STANDARD EQUIPMENT

### Engine

High-performance, low-emission  
Air cleaner, dry type, dual element,  
exhaust-aspirated precleaner  
Coolant level, sight gauge  
Coolant filter water drop  
Engine intake manifold preheater  
Dual fuel filter  
Water trap  
Muffler, spark-arresting  
Fan guard  
Hydraulically driven radiator fan

### Electrical System

24 V – prewired for optional  
accessories  
Alternator, 24 V, 60 A  
Battery disconnect switch  
Fuel gauge  
Engine coolant temperature gauge  
Transmission oil temperature gauge  
Hour meter  
Horn, electric  
Instrument panel with symbols  
Reverse alarm  
Contronic display  
Lights:  
• driving (2-Front), halogen with  
• high/low beam  
• parking lights  
• stop/tail combination (2 rear)  
• turn signals with hazard  
warning switch  
• working lights, halogen  
(2 front, 2 rear)  
• instrument lighting

### Contronic Monitoring System, ECU

Engine shut down to idle  
Brake test  
Neutral start feature  
Test function for warning &  
monitoring lights  
Information panel (Contronic):  
start configuration, setting  
language and units, operating  
hours, general operating informa-  
tion, stopwatch/trip meter, cycle  
counter, service interval  
engine  
electrical system  
transmission  
axles/brakes  
Warning & monitoring lights:  
• air cleaner restriction  
• engine preheater  
• alternator malfunction  
• working lights  
• high beam driving lights  
• direction indicator, hazard  
• differential lock  
Central warning:  
• engine oil pressure  
• engine coolant temperature  
(buzzer)  
• transmission oil pressure  
• transmission oil temperature  
• brake system pressure (buzzer)  
• parking brake applied (buzzer)  
• steering pressure  
• axle oil temperature (buzzer)  
• transmission oil filter  
• engine/transmission overspeed  
(buzzer)

### Drivetrain

Transmission: modulated with  
single lever control, Automatic  
Power Shift generation II, and  
operator controlled declutch  
Forward and reverse switch on  
hydraulic console  
Differentials:  
front 100%, hydraulic  
differential lock  
rear, conventional  
Tires 26.5 R25\* L2

### Brake System

Wet, internal oil circulation-cooled,  
outboard-mounted disc brakes,  
4-wheel, dual circuit  
Brake system, secondary

### Cab

ROPS (SAE J1040CC) (ISO 3471),  
FOPS (SAE J 231) (ISO 3449).  
Acoustical lining  
Ashtray  
Cigarette lighter  
Door lockable (left side access)  
Dual service brake pedals  
Heater/defroster/pressurizer 11 kW  
37500 Btu/h with four-speed  
blower fan  
Filtered air  
Floor mat  
Interior light  
Mirror rearview interior  
Mirrors rearview (2), exterior  
Openable window, right side  
Safety glass, tinted

Tilttable and telescoping steering  
wheel  
Retractable seat belt (SAE J386)  
Seat, heated, ergonomically  
designed, suspension adjustable  
Sliding window door  
Storage compartment  
Sun visor  
Windshield wiper, front & rear  
Intermittent wiper, front  
Washer, front and rear  
Cab access steps and handrails  
Fenders, front & rear with anti-skid-  
tape

### Hydraulic System

Main valve, 3-spool  
Pilot valve, 3-spool  
Vane pump  
Bucket lever detent  
Bucket leveler, automatic with  
position indicator, adjustable  
Boom lever detents  
Boom kickout, automatic, adjustable  
Hydraulic control lever safety latch  
Hydraulic oil cooler  
Boom lowering, stopped engine  
Power-down/float, detent

### External Equipment

Isolation mounts: cab, engine,  
transmission, radiator  
Lifting lugs  
Side panels, engine hood  
Steering frame lock  
Vandalism lock, provision for:  
batteries, engine oil  
Fuel strainer  
Drawbar hitch

## OPTIONAL EQUIPMENT

### Service and maintenance equipment

Toolbox  
Auto lube system

### Engine

Cold starting aid, engine  
coolant preheater (110 V/1500 W)  
Pre-cleaner, oil bath type  
Pre-cleaner, turbo type  
Radiator, corrosion-protected

### Electrical System

Attachment lights (halogen)  
Working lights front, extra  
Working lights rear, extra  
Rotating beacon, amber with  
collapsible mount  
Loud horn, electrical  
Alternator, 100A

### Drivetrain

Limited slip differential, rear axle

### Cab

Installation kit for radio  
Hand throttle  
Sliding Window, right side  
Seat, air-suspended, heated  
Seat belt, 3 in.  
Speedometer  
Air-conditioner  
Left-hand armrest

### Hydraulic System

Hydraulic control, 3rd function  
Hydraulic control, 4th function,  
electrical  
Boom Suspension System  
Hydraulic function 3rd, hydraulic  
pilot hoses preinstalled  
Return line 3rd hydraulic control  
Attachment bracket with separate  
locking system  
Biodegradable hydraulic fluid

### External Equipment

Counterweight 1: 470 kg **1040 lb**  
Counterweight 2: 720 kg **1590 lb**  
Fenders, axle-mounted  
Fenders, rubber extensions

### Other Equipment

Comfort Drive Control (CDC)  
Secondary steering  
External brake oil cooling system  
Long Boom  
Arctic kit

### Protective Equipment

Guards for headlights  
Guards for rear working lights  
Guards for side and rear window  
Windshield guard  
Guards for rear lights  
Bellyguard, front and rear  
Protection plate under cab  
Protection plate, valve front frame

### Tires

26.5-25  
26.5 R25\*  
30/65 R29

### Attachments

Buckets  
• straight edge, rock  
• spade nose, rock  
• general purpose  
• light material  
• hi-dump  
Bucket teeth, bolt-on  
Wear segments between teeth,  
bolt-on  
Cutting edge, 3 pc. reversible,  
bolt-on  
Rock bucket spillguard  
Fork equipment  
Material-handling arm  
Timber grapples  
Rib kits

*Under our policy of continuous product improvement, we reserve the right to change specifications and design without prior notice. The illustrations do not necessarily show the standard version of the machine.*

# VOLVO

Volvo Construction Equipment Group

Ref. No. 22 2 669 2265  
Printed in USA 5/98 - 10.0  
Biltmore Press, Asheville

WLO