

VOLVO WHEEL LOADERS

BLOCK HANDLING



MORE CARE. BUILT IN.



VOLVO'S BEEN AROUND THE BLOCK

With Volvo on the job, moving large, heavy blocks quickly and efficiently is easy. That's because Volvo block handlers are specially equipped with features that ensure heavy lifting and high breakout forces. In combination with a full range of attachments and equipment adapted for block handling, even the largest rocks are no match for Volvo's block handlers.

Volvo knows block handling

Volvo's large wheel loaders have all the features required for continuous operation in tough block handling and demanding rock quarries. High capacity and outstanding rimpull is the result of well-matched components working together in perfect harmony. A wide range of genuine Volvo attachments and optional equipment allows you to tailor the block handler to the job site, making sure that it meets all the demands for efficiency, productivity, and comfort. Together with our well-established service and support network, Volvo Wheel Loaders offers the complete package solution for all your business needs.

Powerful advantages in a heavy-duty application

Volvo's high-performance, low-emission engines develop high torque already at low revs, giving outstanding rimpull and low fuel consumption. The compact design contributes to a tight turning circle, stability, and safety – important features whatever the job.

A global company with local presence

When you buy an F-series Volvo wheel loader, you get not only one of the market's most durable and reliable block handlers. Our global dealer and service network also makes Volvo Construction Equipment your reliable and committed partner. We provide fast access to skilled service personnel and the right spare parts – worldwide. All to optimize your machine's productivity and profitability.





BORN TOUGH. BUILT FOR BLOCK HANDLING FROM THE BEGINNING – VOLVO STANDARD FEATURES

Many standard features built into today's Volvo wheel loaders are specifically developed to withstand tough applications like block handling.

Get more done

High-performance engines with Volvo Advanced Combustion Technology (V-ACT) make Volvo's block handlers both powerful and easy to operate. The V-ACT engines use every drop of fuel, providing high power already at low revs, while meeting all known standards for reduced emissions. The load-sensing hydraulics contributes to low fuel consumption by only using the power that's needed.

Volvo's linkage systems feature excellent rollback angles, keeping the load close to the front axle in the carry position, for good load retention and better stability. Volvo block handlers utilize the same linkage systems as the standard machines, which mean that they can easily be used as bucket handlers to load trucks. This is a distinct advantage over competitive block handlers equipped with shortened booms.

Smooth and safe operation

Volvo Automatic Power Shift (APS) contributes to fast and effective work cycles. The system is dependent on ground speed and engine rpms. All the operator has to do is select forward or reverse.

Volvo's block handlers feature Volvo's all-hydraulic, circulation-cooled, wet disc brakes. They combine long operating life with smooth and effective braking performance.

Keep it running

The Contronic electronic monitoring system continuously controls, monitors, informs, and warns the operator of the machine's status. Other features include monitoring of oil and fluid levels, fuel consumption data, and service intervals.

Operating economy

All systems and components are perfectly matched for operator efficiency, quality and reliability, and low fuel consumption. Lifetime-lubed rear axle suspension, heavy-duty frames and widely spaced, well-sealed center hinge bearings contribute to long life and low operating costs.





TAKING CARE OF BUSINESS

Volvo Care Cab is a safety-conscious work place, stress and vibrations reduced. Climate control and fingertip operation of the load-sensing hydraulics actually make the hard work of block handling quite comfortable. That's why Care Cab helps you to get more done.

A great workplace

You really feel welcome in Volvo's latest cab. It's both wider and deeper than it's predecessor. There is lots of space to stretch out your legs, and ample space for storage boxes, boots, and cups. The large, swept windshield gives excellent visibility in all directions. The Boom Suspension System, (BSS)*, effectively absorbs shocks and reduces the bouncing and rocking that often arises when running on rough ground with a heavy load. BSS improves cycle times and operator comfort. Seat adjustments make it easy to find a comfortable operating position.

Always a comfortable climate

Volvo's unique and patented two-stage cleaning recirculates up to 90 percent of the air, and only 10 percent comes from the outside. The air in the cab is cleaned to 98 percent. Automatic Heat Control (AHC) is standard and ensures a comfortable temperature in the cab. And if the operator needs a break, the timer cab heating* can be left on even with the engine off, which both saves fuel

and protects the environment. Automatic climate control (ACC) is available as an option for L150F-L220F and is standard on L350F.

Block handling at your fingertips

With lever steering Comfort Drive Control (CDC)* (std. on L350F), the operator can handle steering and shifting forward/reverse with controls in the left armrest to avoid static muscle loads. For using hydraulically controlled attachments, Volvo wheel loaders can be equipped with third and fourth hydraulic functions*, which are operated with additional control levers. Pilot-operation with electro-servo hydraulics* (std. on L350F) increases both comfort and control.

* Optional equipment





TAILORED TO YOUR APPLICATION - VOLVO BLOCK HANDLER

Volvo offers a full range of equipment and attachments that have been purpose-designed for your business. You choose the options that are right for you and your operation.

Tailored for effective block handling

Volvo L350F block handlers are available in two versions, standard and heavy-duty. Both are modified for extremely heavy lifting and to handle rough operating conditions when running long shifts in demanding rock quarries. They are just as smooth, operator-friendly, and easy on fuel as a standard Volvo L350F – even with their massive counterweights.

Standard Volvo L350F block handler kit

This equipment package modifies Volvo's L350F block handlers to boost capacity for lifting and carrying big, heavy blocks, and to withstand the rugged conditions in block handling.

- Additional counterweight 2,426 kg
- Larger lift cylinders
- Tires: GoodYear 875/65 R33** RL-5K*
- Tires: GoodYear 875/65 R33** RL-4K*

Heavy-duty Volvo L350F block handler kit

With equipment for 'heavy-duty', the Volvo L350F can take on even more demanding conditions and jobs. Larger lift cylinders provide greater lifting capacity. The extra counterweight contributes to a significant increase in tipping load.

- Additional counterweight 7,769 kg
- Larger lift cylinders
- Tires: GoodYear 875/65 R33** RL-5K*
- Tires: GoodYear 875/65 R33** RL-4K*

* Recommended optional tires





BUILT TO RUN. SUPPORTED FOR LIFE

When you invest in a Volvo wheel loader, you get a block handler of the very highest quality. But of course, even the best machines need service and maintenance to be as productive tomorrow as they are today. Customer Support will help you to keep an eye on your owning and operating costs.

We care about your operation - anywhere, anytime

Volvo Construction Equipment and Volvo Wheel Loaders center around a professional Customer Support organization, providing parts supply, after sales services and training. All this gives customer benefits through controlled owning and operating costs. When you invest in a Volvo wheel loader, the availability of good service and access to genuine Volvo parts are just as important as the price. After all, it is the total cost during the machine's entire life that's interesting. With all the products and resources we have at our disposal, we can offer you the best support. Anywhere, anytime.

Four levels of support, one level of care

The best way to get the most out of your Volvo wheel loader is to invest in a Volvo Customer Support Agreement. There are four levels of agreements designed to give

you total peace of mind; white, blue, silver, and – of course – gold, which includes all service, maintenance, and repairs during the whole contract period at a fixed price. From this completely flexible starting point, we can create an agreement uniquely tailored to the needs of your business and the age of your loaders.

Genuine Volvo parts leave nothing to chance

Each genuine Volvo part is developed for and manufactured together with all other machine components. It's a complete system where each part works in perfect harmony with other parts. Only by using genuine parts can you be sure that your machine retains the qualities and features we gave it from the beginning.

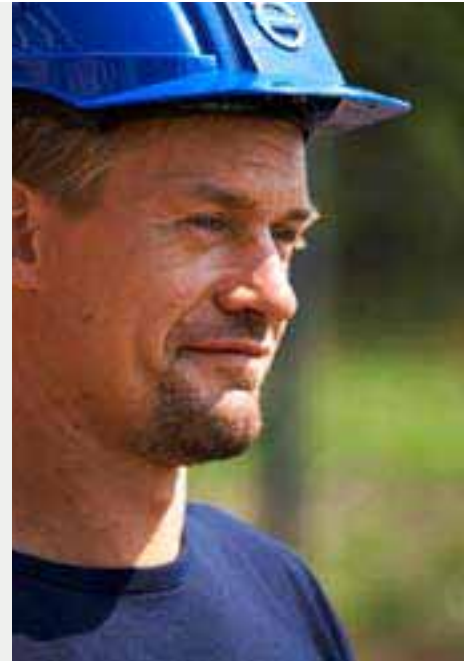

OPTIONS TO BOOST YOUR MACHINE PERFORMANCE AND TO PROTECT YOUR INVESTMENT



Boom Suspension System (BSS)

BSS effectively absorbs shocks and reduces the bouncing and rocking that often occurs when operating on rough ground. Volvo's Boom Suspension System offers improved operator comfort in all types of block handling applications.

Electro-hydraulic control

Pilot-operation with electric-servo hydraulics increases comfort with lighter lever forces and high precision. Adjustable lift and bucket angles, Return-to-dig, and end-position damping are built-in functions (std on L350F).

External Axle Oil Cooling

Provides effective cooling of the axle oil and brakes in applications where heavy loads and constant braking are common. Optional axle oil cooling provides maximized cooling capacity.

Comfort Drive Control (CDC)

When operating with CDC, there is a significant reduction of repetitive and tiring steering wheel movements. Comfort Drive Control provides comfortable operation of steering and shifting with user-friendly controls integrated in the left armrest (std. on L350F). When operating on public road – always use the steering wheel.

Rear-view Camera System

Rear-view camera system reduces blind spots and increases site when reversing and also improves operator comfort. Standard in certain market.

Mudguards

Swing-out rear mudguards – to protect the machine in extreme conditions.

CareTrack Telematics System

Remote monitoring of the machine's position, utilization, and performance. Forwarding of error codes, alarms, and service reminders. Position on map plus Geo- & Time-fence functions.

Automatic Lubrication System

Volvo's factory-installed central lubrication system automatically lubricates service points on the machine so you don't have to. It cuts maintenance costs and downtime, which means higher productivity and lower operating costs.

PURPOSE-BUILT FOR BLOCK HANDLING - GENUINE VOLVO ATTACHMENTS



L150F-220F Hydraulic attachment bracket



L350F Hydraulic attachment bracket



L150F-L220F Spade nose rock bucket



L350F Spade nose rock bucket



L150F-L180F Block forks



L220F-L350F Block forks



L150-L350F Breaker tine



L150-L350F Clearing rake

Attachment Bracket

The hydraulic attachment bracket makes it quick and easy to change between different block handling attachments depending on the job at hand.

Block Forks

Heavy-duty fork tines are designed for lifting and moving blocks in quarry operations. The fork tine geometry keeps the load close to the front axle in carry position for good load retention and safe handling.

Hook-on Spade Nose Rock Bucket for Block Applications

With its strength and performance, the hook-on spade nose rock bucket is the best choice for loading out rock or overburden in block quarries. It features wear resistant steel to give maximum strength for long life.

Breaker Tine

The heavy-duty single fork tine is designed for breaking out loose blocks from the face and moving raw blocks. The center-mounted tine allows forces acting on the machine to be evenly distributed and also maximizes the usable force. A notch at the end of the extra thick tine gives better leverage.

Clearing Rake

The clearing rake is used for moving objects or clearing debris.

Attachment	Volvo L150F				Volvo L180F				Volvo L220F				Volvo L350F			
	Width	Length	Weight	Volume	Width	Length	Weight	Volume	Width	Length	Weight	Volume	Width	Length	Weight	Volume
	mm	mm	kg	m ³	mm	mm	kg	m ³	mm	mm	kg	m ³	mm	mm	kg	m ³
Attachment bracket	1 340	-	580	-	1 340	-	580	-	1 307	-	615	-	1 990	-	1 830	-
Spade nose rock bucket*	3 030	1 610	2 270	3,6	3 230	1 620	2 530	4,1	3 430	1 740	2 630	4,4	3 960	2 020	5 120	6,2
Block forks	1 420	1 990	1 800	-	1 420	1 990	1 800	-	1 420	1 990	1 800	-	2 100	2 060	3 000	-
Breaker tine	1 450	1 470	1 800	-	1 450	1 470	1 800	-	1 450	1 470	1 800	-	2 100	1 430	2 700	-
Clearing rake	2 500	8 730	5 000	-	2 500	8 730	5 000	-	2 500	8 730	5 000	-	2 500	8 530	5 400	-

* L180F, L220F, L350F Hook-on bucket, dimensions based on L5 tires. L150F Pin-on bucket, based on L5 tires.

Option**Block handling equipment kit****L150F L180F L220F L350F**

	L150F	L180F	L220F	L350F
Block handler kit				•
Block handler, heavy-duty				•
Counterweight, block handling			•	
Counterweight, log handling	•	•		

Block Handling attachment

Block Fork	•	•	•	•
Breaker Tine	•	•	•	•
Clearing Rake	•	•	•	•
Hook-on Spade Nose Rock Bucket for Block Application				•
Hook-on Straight or Spade Nose Rock Bucket, 150 pin-on	•	•	•	

Optionals to boost your machine performance

Boom Suspension, BSS	•	•	•	•
Comfort Drive Control, CDC	•	•	•	
Comfort Drive Control, CDC, in combination with electro-hydraulic	•	•	•	std
Electro-hydraulic servo control	•	•	•	std
Electro-hydraulic servo control, 3rd function	•	•	•	
Electro-hydraulic servo control, 3rd and 4th function	•	•	•	
Hydraulic, 3rd and 4th function	•	•	•	
Hydraulic attachment bracket	•	•	•	•

Optionals to protect your investment

CareTrack	•	•	•	•
Hydraulic oil cooler, extra	•	•	•	
Lube System, ARV plant, prod.adapted	•	•	•	•
Lube System, for attachm bracket, welded	•	•	•	
Mudguards fixed front and swing out rear, mudguards wideners incl.	•	•	•	•
Oil cooler for front + rear axle				•
Oil cooler and filter for front + rear axle	•	•	•	
Rear view camera incl. monitor, colour – std in certain markets	•	•	•	•

SPECIFICATIONS

The graph below show the tipping load and lifting force versus hinge pin height. The maximum rated load should be calculated according to ISO 14397-1, which is based on the following criteria.

- Machine speed less than 2 km/h (1.2mph)
- Machine in straight-ahead position
- Load rolled back
- Load lifted to the maximum moment arm (max. reach)
- Center of gravity of load at X:900 mm (2'11") and Y: 800 mm (2'7")
- Maximum tipping load utilization at 80 %



Volvo L150F*

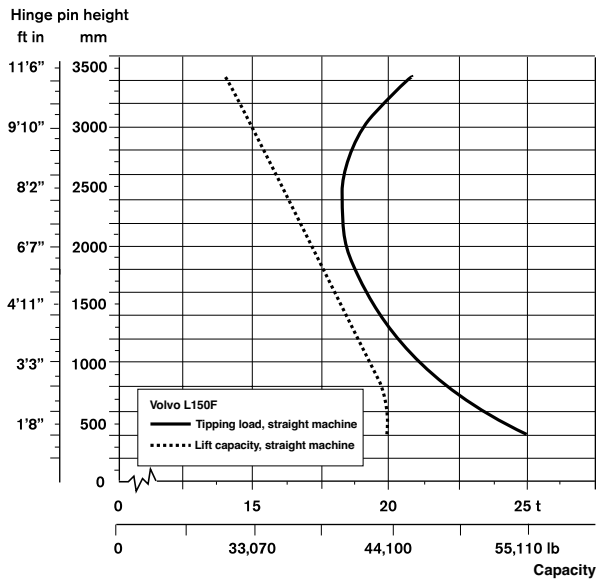

Volvo L180F*

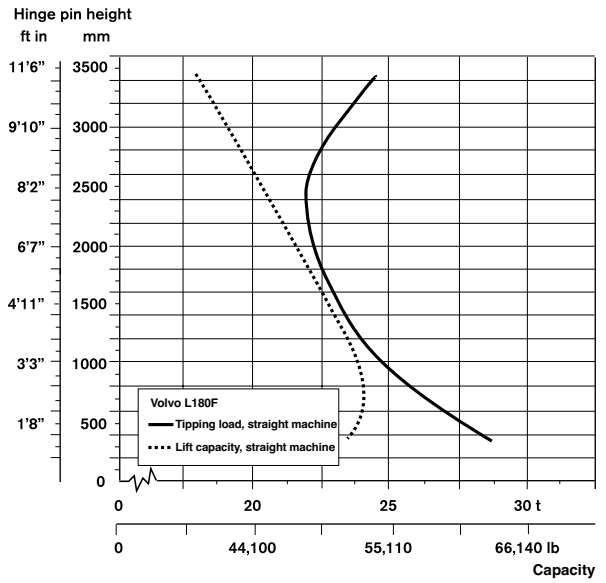

Volvo L220F*

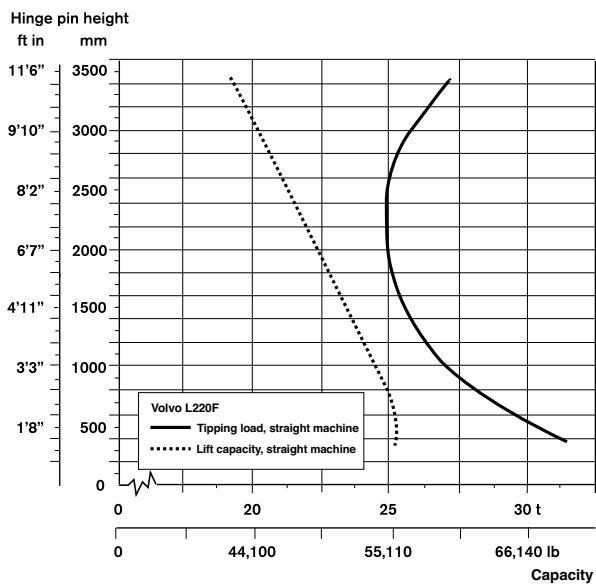

Volvo L350F**

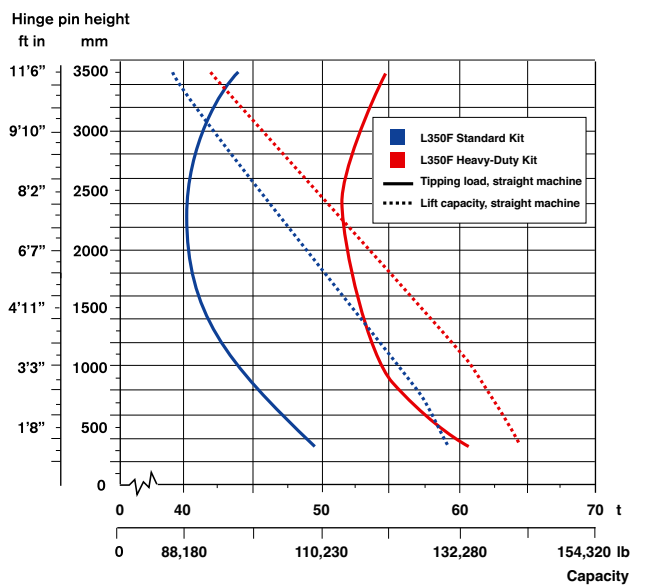

*) Equipped with logging counterweight and L5 tires. (L220F equipped with extra counterweight for block handling).

) L350F HD Block handler: the machines loading capacity exceeds the maximum permissible load for the actual tire dimension. Available tire from factory is 875/65 R33 which is approved for 38t (83,770lb) working load.



Equipped with block forks

		Volvo L150F	Volvo L180F	Volvo L220F	Volvo L350F Std BH	Volvo L350F H-D BH
A _c Overall length	mm (ft in)	9 125 (29'11")	9 225 (30'3")	9 530 (31'3")	11 295 (37'1")	11 490 (37'8")
A _r Reach at min. lift	mm (ft in)	970 (3'2")	1 060 (3'6")	1 140 (3'9")	1 180 (3'11")	1 180 (3'11")
B Reach at tipping position	mm (ft in)	1 740 (5'9")	1 830 (6'0")	1 900 (6'3")	2 030 (6'8")	2 030 (6'8")
C Height at min. lift	mm (ft in)	- 31 (- 0'1.2")	6 (0'2")	-19 (- 0'7")	131 (0'5.1")	126 (0'5")
D Height at tipping position	mm (ft in)	2 010 (6'7")	2 020 (6'7")	2 090 (6'10")	D2 290 (7'6")	2 290 (7'6")
E Height at max. lift	mm (ft in)	4 050 (13'3")	4 190 (13'9")	4 370 (14'4")	4 650 (15'3")	4 650 (15'3")
L Load center distance	mm (ft in)	900 (2'11")	900 (2'11")	900 (2'11")	900 (2'11")	900 (2'11")
R _i Max rollback angle in carrying pos	° (°)	49,4 (49,4)	49 (49)	47 (47)	46 (46)	46 (46)
Optional counterweight	kg (lb)	1 140 (2,510)	1 140 (2,510)	1 515 (3,340)	2 426 (5,350)	7 769 (17,130)
Operating weight (without load)	kg (lb)	25 510 (56,250)	28 350 (33,430)	33 430 (73,720)	52 530 (115,830)	57 870 (127,610)

Equipped with rock bucket

		Pin on	Hook on	Hook on	Hook on	Hook on
A _c Overall length	mm (ft in)	8 890 (29'2")	9 250 (30'4")	9 670 (31'9")	11 199 (36'9")	11 200 (36'9")
a ₁ Clearance circle	mm (ft in)	14 800 (48'7")	15 020 (49'3")	15 820 (51'11")	18 250 (59'10")	18 150 (59'7")
a ₄ Max articulation angle	° (°)	37 (37)	37 (37)	37 (37)	37 (37)	37 (37)
B Overall length w/o bucket / attachm. bracket	mm (ft in)	7 070 (23'2")	7 170 (23'6")	7 470 (24'6")	9 130 (30'0")	9 330 (30'8")
E Digging depth, mac dump (S)	mm (ft in)	1 480 (4'10")	1 760 (5'9")	1 810 (5'11")	1 730 (5'8")	1 730 (5'8")
R _i Max rollback angle in carrying pos	° (°)	47 (47)	47 (47)	45 (45)	44 (44)	44 (44)
H Dump clearance	mm (ft in)	2 840 (9'4")	2 830 (9'3")	2 970 (9'9")	3 420 (11'3")	3 420 (11'2")
M Dump reach	mm (ft in)	1 410 (4'8")	1 600 (5'3")	1 760 (5'9")	2 230 (7'4")	2 230 (7'4")
P Max possible forward dump at K (max. HPH)	° (°)	50 (50)	45 (45)	43 (43)	47 (47)	47 (47)
R Max rollback angle at ground level	° (°)	45 (45)	44 (44)	43 (43)	39 (39)	39 (39)
S Max forward dump at lowest lifting arm position	° (°)	66 (66)	71 (71)	65 (65)	63 (63)	63 (63)
T Digging depth	mm (ft in)	80 (0'3.2")	129 (0'5.1")	113 (0'4.4")	65 (0'2.6")	70 (0'2.8")
U Hinge pin height in carrying position	mm (ft in)	530 (1'9")	540 (1'9")	560 (1'10")	620 (2'1")	620 (2'1")
Bucket width	mm (ft in)	3 230 (127")	3 230 (127")	3 430 (135")	3 960 (155")	3 960 (155")

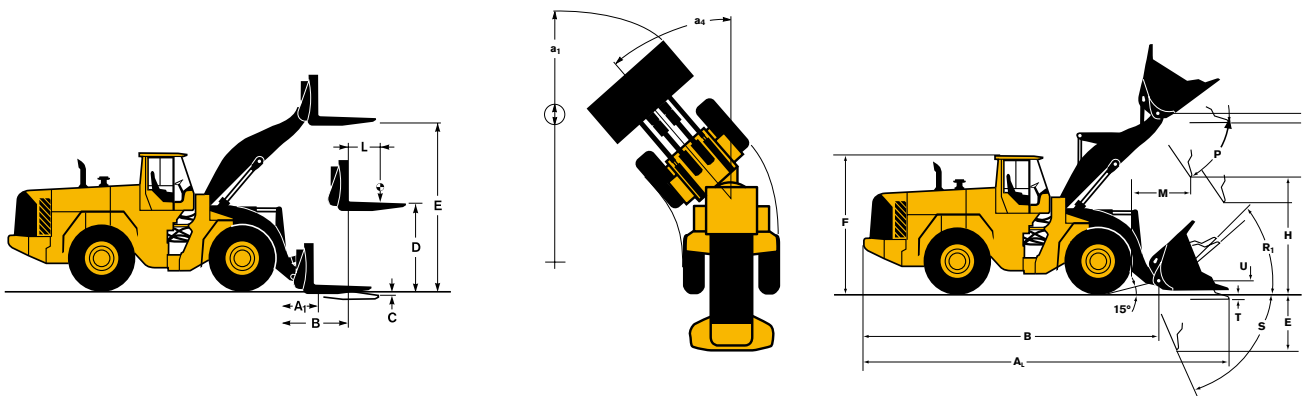

Note: Dimensions only apply to genuine Volvo attachments.
For additional dimensions, see standard machine product brochure.

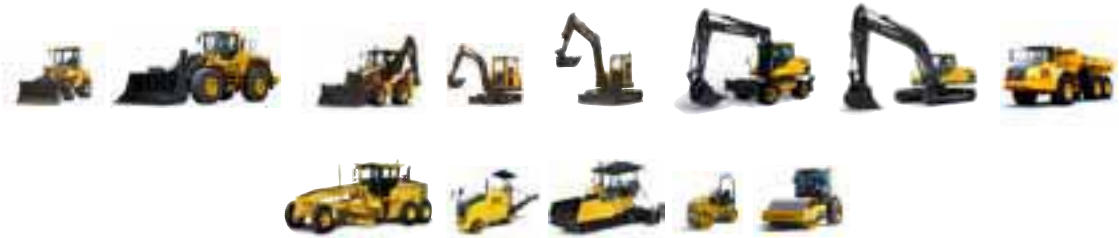

Volvo Construction Equipment is different. Our machines are designed, built and supported in a different way. That difference comes from an engineering heritage of over 175 years. A heritage of thinking first about the people who actually use the machines. About how to help them be safer, more comfortable, more productive. About the environment we all share. The result of that thinking is a growing range of machines and a global support network dedicated to helping you do more. People around the world are proud to use Volvo. And we're proud of what makes Volvo different – **More care. Built in.**



Not all products are available in all markets. Under our policy of continuous improvement, we reserve the right to change specifications and design without prior notice. The illustrations do not necessarily show the standard version of the machine.

VOLVO

Volvo Construction Equipment
www.volvoce.com

Ref. No. VOE21A1003718
Printed in Sweden 2009-03-3,0
Volvo, Eskilstuna

English
WLO