

# VOLVO BM 841



## All-round

Standard attachment bracket for snap-on coupling of various attachments — wide range of attachments.

## Nimble

Small turning radius and power-shift transmission.

## “Go-anywhere” mobility

Oversized wheels, 4-wheel drive and differential lock.

## Economy

Reliable — simple construction with quality components, low fuel consumption.

## Capacity

Gets the job done quickly thanks to a powerful engine and a loading unit with high lift and long outreach.

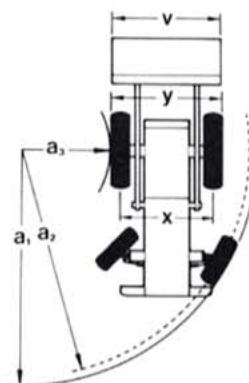
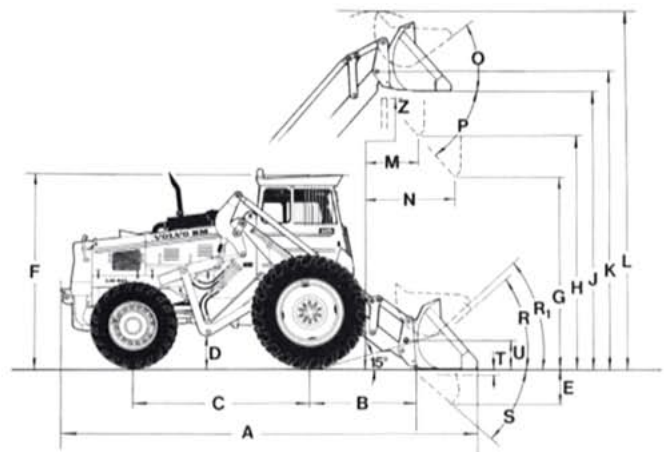

DIMENSIONS			
A	5750 mm (226.4")	R <sub>i</sub>	44° in carrying position
B	1500 mm (59.1")	S	43°
C	2435 mm (95.5")	T	100 mm (4")
D	390 mm (15.4")	U	450 mm (18")
E	640 mm (25.2")	Z	3530 mm (140")
F	2760 mm (108.7")	a <sub>1</sub>	5850 mm (230")
G	2000 mm (79.0")	a <sub>2</sub>	5700 mm (224")
H	3100 mm (122.1")	v	2800 mm (110")
J	3600 mm (141.7")	V	2200 mm (87")
K	3900 mm (153.5")	X Front	1820 mm (71")
L	4600 mm (181.1")	X Rear	1850 mm (72")
M	1000 mm (39.4")	Y	2250 mm (88")
N	1400 mm (55.1")		
O	40°		
P	48°		
R	45°		

# SPECIFICATION VOLVO BM LOADER 841

## Engine

6-cyl. VOLVO D 50 B  
Displacement 5,13 dm<sup>3</sup> (313 in<sup>3</sup>)  
Max. rating at 40 r/s (2400 RPM)  
SAE/DIN 82, 4/71, 4 kW (112/97 hp)  
Max. torque at 28 r/s (1700 RPM)  
SAE/DIN 348/313 Nm (257/230 lb.ft)

## Electrical system

Voltage ..... 24 V  
Alternator ..... 700 W  
Starter motor ..... 3 kW (4 HP)

## Transmission

Torque converter and power-shift gear-box.  
Two speed ranges with a total of 4 forward speeds and 4 reverse. Differential lock.

## Speeds

Forward and reverse m/s (mph)  
I 0—2,3 m/s (0— 5 mph)  
II 0—3,6 m/s (0— 8 mph)  
III 0—5,7 m/s (0—13 mph)  
IV 0—8,3 m/s (0—19 mph)

## Brakes

Driving brakes: Hydraulic disc brakes  
Braking area .... 1850 cm<sup>2</sup> (287 in<sup>2</sup>)  
Steering brake  
Parking brake

## Steering system

Hydrostatic with double cylinders on the steering axle

## Loading unit

Max. lifting height under  
dumped bucket ..... 3,1 m  
(10 ft 2 in)  
Outreach at 2 m (6 ft in)  
45° dumped bucket ..... 1,4 m  
(4 ft 7 in)  
Transport load  
carrying position ..... 3200 kg  
(7050 lb)  
Standard bucket SAE ..... 1,3 m<sup>3</sup>  
(1,7 cu.yd.)  
Break-out force SAE ..... 53900 N  
(12130 lbf)

## Hydraulic system

Hydraulic pump  
capacity ..... 3,7 dm<sup>3</sup>/s  
(48 Imp.gal./m)  
Working pressure .. 100 kp/cm<sup>2</sup>  
(1420 lb/p.s.i.)

## General data

Total weight with  
bucket ..... 9870 kg (21800 lb)  
Wheelbase ..... 2,44 m (8 ft)  
Track front/rear .... 1,90/1,85 m (6 ft 8 in/6 ft 1 in)  
Machine width ..... 2,38 m (7 ft 8 in)  
Turning radius ..... 5,70 m (18 ft 8 in)  
with steering brake .. 3,5 m (11 ft 5 in)  
Tyres front ..... 18.4—34/14  
rear ..... 14.9—24/14

## Standard equipment

Rear-view mirror, interior (2)  
Lighting  
main headlamps, bright/dim  
working lights, rear (2)  
parking lights  
back-up lights and brake lights  
position lights  
cab light  
Fuel gauge  
Differential lock, jaw clutch  
Tyre equipment (sep. specification)  
Air pre-cleaner  
Main switch  
Cab  
Storage basket in cab  
Cab heating with fresh-air intake  
Instrument panel with symbol markings  
Indicator lamp for rear working lights  
Charging indicator lamp  
Bright light indicator  
Direction indicators  
Air filter indicator  
Control level and tubes for 3rd  
hydraulic function  
Attachment bracket, mechanical  
Spring-cushion seat  
Horn  
Protective screen for lower side window  
Outlet for trailer lighting  
Sun visor  
Lifting lever lock connected to cab door  
Seat belt mountings  
Safety start  
Hour counter  
Engine water thermometer  
Hazard flashers  
Indicator lamp for above  
Warning lamp for parking lights  
Warning lamp for transmission oil  
temperature  
Warning lamp for transmission oil  
pressure  
Warning lamp for motor oil pressure  
Tool kit  
Windshield wiper, front windshield  
Alternator

## Optional equipment

Front working lights  
Extra fuel filter  
Belly guards  
Towing hitch  
Floating crane  
Tinted cab windows  
Grille door  
Spark arrester  
Hydraulic outlet for trailer tipping  
Cab ventilator  
Indicator lamp for air brakes  
Lifting eyes  
Control lever, tubes and valve for 4th  
hydraulic function  
Control lever (common for 3rd hydraulic  
function), tubes and valve for 4th  
hydraulic function  
Engine heater, electrical  
Engine heater, LP gas  
Attachment bracket, hydraulic  
Tyre pumping equipment  
Protective grilles for beams  
Outlet for inspection lamp  
Outlet for trailer brakes  
Steering brakes  
Safety belt  
Air compressor  
Pressure gauge for air brakes  
Rotating beacon, incl. folding bracket  
Rotating beacon  
Folding bracket for above

Specifications are subject to alteration without prior notice.

# VOLVO BM

VOLVO BM AB ESKILSTUNA SWEDEN

Ref. No. 2323 GB

4. 8. 74 KURIR-tryck Katrineholm 49926