

VOLVO BM 621



All-round

Standard attachment bracket for snap-on coupling of various attachments — wide range of attachments.

Nimble

Small turning radius and power-shift transmission.

Capacity

Fast-working with powerful engine and a loading unit with high lift and long outreach.

Economy

Reliable — simple construction with quality components, low fuel consumption.

Safety - comfort

Comfortable safety cab with low noise level and good vision.

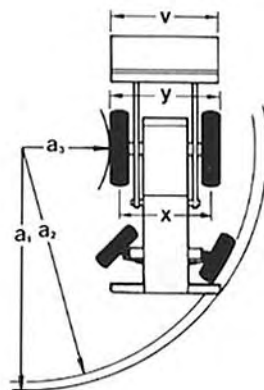
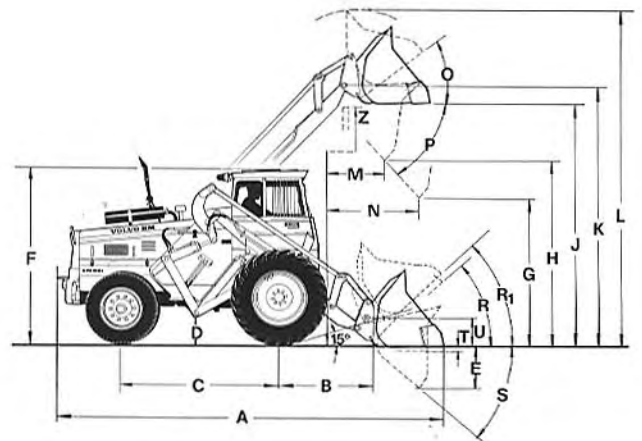

DIMENSIONS

| | | | |
|---|----------------|----------------|--------------------------|
| A | 217" (5550 mm) | R ₁ | 44° in carrying position |
| B | 57" (1450 mm) | S | 42° |
| C | 93" (2380 mm) | T | 4" (100 mm) |
| D | 14" (350 mm) | U | 18" (450 mm) |
| E | 28" (710 mm) | v | 87" (2200 mm) |
| F | 104" (2640 mm) | x front | 71" (1820 mm) |
| G | 79" (2000 mm) | Rear | 67" (1700 mm) |
| H | 114" (2900 mm) | y | 88" (2250 mm) |
| J | 142" (3600 mm) | Z | 139" (3530 mm) |
| K | 151" (3850 mm) | | |
| L | 185" (4700 mm) | a ₁ | 288" (5300 mm) |
| M | 33" (750 mm) | a ₂ | 286" (5250 mm) |
| N | 55" (1400 mm) | a ₃ | 98" (2500 mm) |
| O | 41° | | |
| P | 45° | | |
| R | 42° | | |

SPECIFICATION VOLVO BM LOADER 621

Engine

4-cyl VOLVO BM D 42 diesel engine with direct injection

| | |
|--------------------------------------|---------------------------------|
| Displacement | 256 in ³ (4.2 l) |
| Max. rating at 2 300 rev/min SAE/DIN | 80/70.5 hp |
| Max. rating at 38.4 rev/min SAE/DIN | 59/55 kW |
| Max. torque at 1 400 rev/min SAE/DIN | 198/185 ft-lbf (27.4/25.6 kgfm) |
| Max. torque at 23.4 rev/min SAE/DIN | 20/18.4 lbf (270/250 Nm) |

Electrical system

| | |
|---------------|-------------|
| Voltage | 20 V |
| Alternator | 700 W |
| Starter motor | 3 kW (4 hp) |

Transmission

Torque converter and power-shift gearbox. Two speed ranges with a total of 4 forward speeds and 4 reverse. Differential lock.

Speeds

| | |
|--------------------------------|--|
| Forward and reverse mph (km/h) | |
| I 0—4.8 (0—7.7) | |
| II 0—7.4 (0—12) | |
| III 0—11.8 (0—19.0) | |
| IV 0—19 (0—30.0) | |

Brakes

| | |
|-----------------------|--|
| Driving brakes: | |
| Hydraulic disc brakes | |
| Braking area | 286 in ² (1 850 cm ²) |
| Steering brake | |
| Parking brake | |

Steering system

Hydrostatic with double cylinders on the steering axle

Loading unit

| | |
|--|--|
| Max. lifting height under tipped bucket | 9 ft 6 in (2.9 m) |
| Outreach at 6 ft 7 in (2 m), 45° tipped bucket | 4 ft 7 in (1.4 m) |
| Tipping load SAE | 7 260 lb (3 300 kg) |
| Standard bucket SAE | 35 ft ³ (1.0 m ³) |
| Break-out force SAE | 9 260 lbf (4 200 kgf) |

Hydraulic system

| | |
|-------------------------|---|
| Hydraulic pump capacity | 32 Imp.gal/min (145 l/min) |
| Working pressure | 1630 lbf/in ² (115 kgf/cm ²) |

General data

| | |
|--------------------------|-----------------------------------|
| Total weight with bucket | 16 940 lb (7 700 kg) |
| Wheelbase | 7 ft 8 in (2.38 m) |
| Track front/rear | 6 ft 3 in/5 ft 7 in (1.82/1.70 m) |
| Machine width | 7 ft 4 in (2.25 m) |
| Turning radius | 17 ft 3 in (5.25 m) |
| with steering brake | 10 ft 10 in (3.3 m) |
| Tyres front | 16.9—30/14 |
| rear | 9.00—20/10 |

Standard equipment

Rear-view mirror, interior (2)
 Lighting
 main headlamps, bright/dim
 working lights, rear (2)
 parking lights
 back-up lights and brake lights
 position lights
 cab lights
 Fuel gauge
 Dust ejector (for automatic emptying of air filter's pre-cleaner)
 Tyre equipment (sep. specification)
 Storage basket in cab
 Main switch
 Cab
 Cab heating with fresh-air intake vent
 Instrument panel with symbol markings
 Indicator lamp for rear working lights
 Charging indicator lamp
 Bright light indicator
 Direction indicators
 Air filter indicator
 Control lever and tubes for 3rd hydraulic function
 Attachment bracket, mechanical
 Spring-cushion seat
 Horn
 Protective screen for lower side window
 Sun visor
 Lifting lever lock connected to cab door
 Steering brake
 Seat belt mountings
 Safety start
 Hour counter
 Engine water thermometer
 Hazard flashers
 Indicator lamp for above
 Warning lamp for parking lights
 Warning lamp for transmission oil temperature
 Warning lamp for transmission oil pressure
 Warning lamp for motor oil pressure
 Tool kit
 Windshield wiper, front windshield
 Alternator

Optional equipment

Front working lights
 Extra fuel filter
 Belly guards
 Towing hitch
 Floating crane
 Tinted cab windows
 Grille door
 Spark arrester
 Hydraulic outlet for trailer tipping
 Cab ventilator
 Lifting eyes
 Control lever, tubes and valve for 4th hydraulic function
 Control lever (common for 3rd hydraulic function), tubes and valve for 4th hydraulic function
 Engine heater, electrical
 Engine heater, LP gas
 Attachment bracket, hydraulic
 Tyre pumping equipment
 Outlet for trailer brakes
 Electrical outlet, trailer
 Safety belt
 Air compressor
 Pressure gauge for air brakes
 Rotating beacon, incl. folding bracket
 Rotating beacon

Specifications are subject to alteration without prior notice.

VOLVO BM

VOLVO BM AB ESKILSTUNA SWEDEN

Ref.No. 21 1 669 1050
 ENGELSKA