

TRACTOR **VOLVO BM 4200**



Specification Volvo BM 4200 tractor

MOBILITY

Large wheels together with articulated steering provide stability and mobility — the 4200 can therefore work on various surfaces on and off the road.

CAPACITY

Quick and nimble — small turning radius and easy-to-operate power shift transmission.

COMFORT

The cab is roomy and comfortable. It is well-insulated and has a very efficient ventilation system.

ECONOMY

Reliable — simply constructed of quality components, low fuel consumption.





ENGINE

D 39L

Flywheel rating	49 kW at 36.7 rps DIN 70020 (67 hp at 2200 rpm)
Gross rating	51.5 kW at 36.7 rps, SAE J 270 (70 hp at 2200 rpm)
Max. torque	254 Nm at 23.2 rps, DIN 70020 (26 kpm at 1400 rpm) 261 Nm at 23.2 rps, SAE J 270 (26.5 kpm at 1400 rpm)
Bore	98.4 mm (3.87 in)
Stroke	127 mm (5.0 in)
No. of cylinders	4
Displacement	3.86 litres (235 in ³)

The D 39L engine is a direct-injected diesel engine with replaceable cylinder linings, light-metal alloy pistons and a crankshaft carried in five bearings. The intake air is cleaned in two stages:

1. Large replaceable paper filter with cab-mounted indicator
2. Replaceable catch-all filter



ELECTRICAL SYSTEM

Voltage	24 V
Alternator	45 A (1250 W)
Batteries	2 x 12 V, 96 Ah
Starter motor	3 kW (4 hp)

The alternator guarantees sufficient battery charging, even at the low engine speeds. The powerful starter motor facilitates starting at low temperatures as well. The driving and working lights permit safe and efficient work in the dark. The fuses are well protected and easily accessible inside the cab.

Central warning lamp for:

- Engine oil pressure
- Transmission oil pressure
- Brake pressure and parking brake



TORQUE CONVERTER

Single-stage, single-phase torque converter

Torque conversion ratio 2.6:1



TRANSMISSION

Type: HT 50

Full power shift transmission with three speeds and torque converter.

Max. speeds forward/reverse with tyres 15.5–25 or 14.9–24	<ol style="list-style-type: none"> 1. 7 km/h (4.4 mph) 2. 11 km/h (6.8 mph) 3. 30 km/h (18.6 mph)
---	--



AXLES

Fully floating drive shafts transmit the torque only and do not support the weight of the machine. They are fitted with planetary gears in the hubs. The long wheelbase and the large wheels contribute to the 4200's excellent stability and forward mobility.



BRAKES

Driving brakes

All wheels have air-hydraulically operated, self-adjusting drum brakes. For maximum safety, the brakes are split into two independent circuits, one for the front and one for the rear wheels.

Parking brake: Mechanically operated on the transmission's output shaft.



TYRES

Alternatives: 14.9–24/12
15.5–25/12



STEERING SYSTEM

Articulated steering

Steering angle	± 45°
Outer turning radius	(a ₂) 4260 mm (168 in)
Pump, type	Gear pump
Capacity	48 l/min (12.7 US gal/min, 10.5 Imp gal/min) at 10 MPa (1450 psi) and 2200 rpm
Working pressure	10 MPa (1450 psi)

The construction guarantees simple, smooth steering without bumps and jolts being felt through the steering wheel. The system has built-in emergency steering.



HYDRAULIC SYSTEM

Pump, type	Gear pump
Capacity	103 l/min (27.2 US gal/min, 22.6 Imp gal/min) at 10 MPa (1450 psi) and 2200 rpm
Working pressure	15 MPa (2175 psi)

Control valve: Valve with three spools and built-in relief valve

The hydraulic system is equipped with a third hydraulic function as standard and can easily be supplemented with a fourth hydraulic function. The hydraulic tank is extra large to provide maximum cooling of the oil. The vent air from the tank passes through the engine's air cleaner.



VOLUMES

	Litres	US gal	Imp gal
Cooling system	18	4.8	4.0
Crankcase	7.5	2.0	1.6
Transmission and torque converter	18	4.8	4.0
Front axle differential and hub	7.5	2.0	1.6
Rear axle differential and hub	7.5	2.0	1.6
Hydraulic system	105	27.7	23.1
Hydraulic tank	67	17.7	14.7
Fuel tank	95	25.1	20.9



CAB

The all-welded ROPS cab, which not only meets the requirements of ISO 3471 but also the more stringent requirements of SS 783, has two lockable doors and a roof hatch.

The cab is approved in accordance with the standards of the Swedish Board of Occupational Safety and Health. The operator's station is ergonomically designed for optimum comfort and efficiency. All controls and pedals are located and designed for convenient and quick operation. Fully adjustable operator's seat as standard. The cab is equipped with an efficient heating and ventilation system with defroster for the front and side windows. The cab is mounted on the chassis via rubber pads, which contribute towards the low noise level inside the cab.

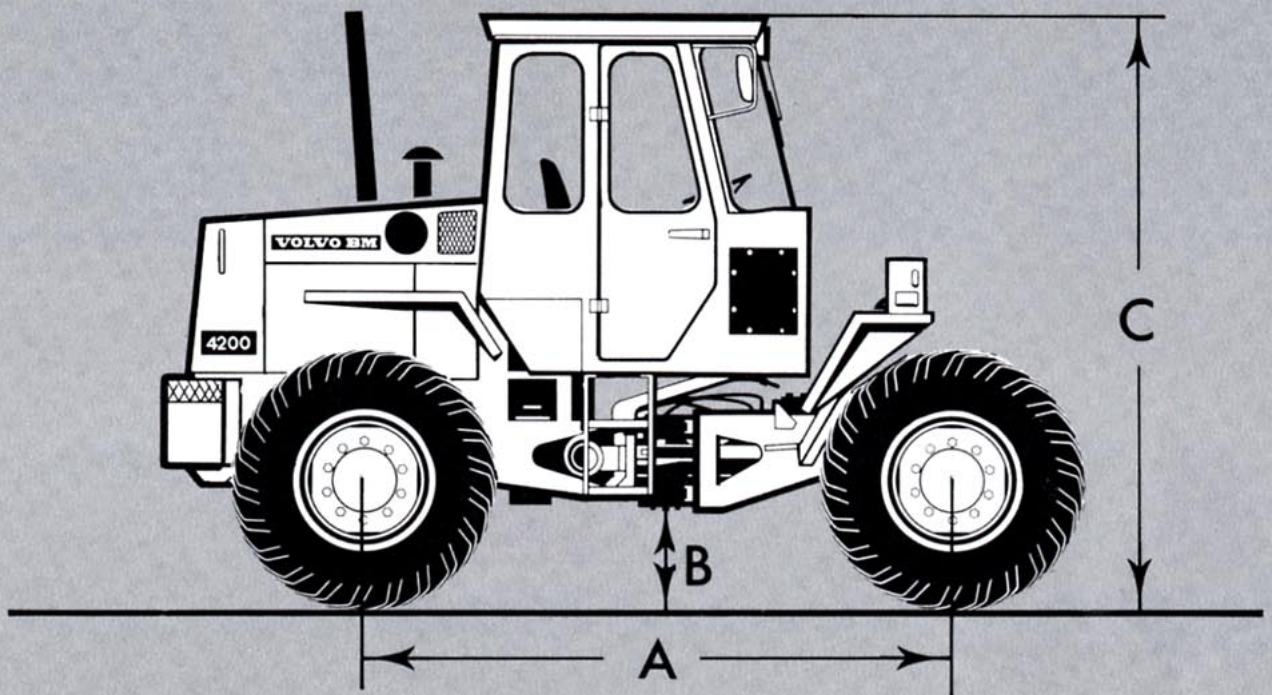

DIMENSIONS

A	2725 mm
B	380 mm
C	2750 mm
a ¹	4310 mm
a ²	4260 mm
a ³	2280 mm
x	1600 mm
y	1990 mm

Machine weight 4 300 kg

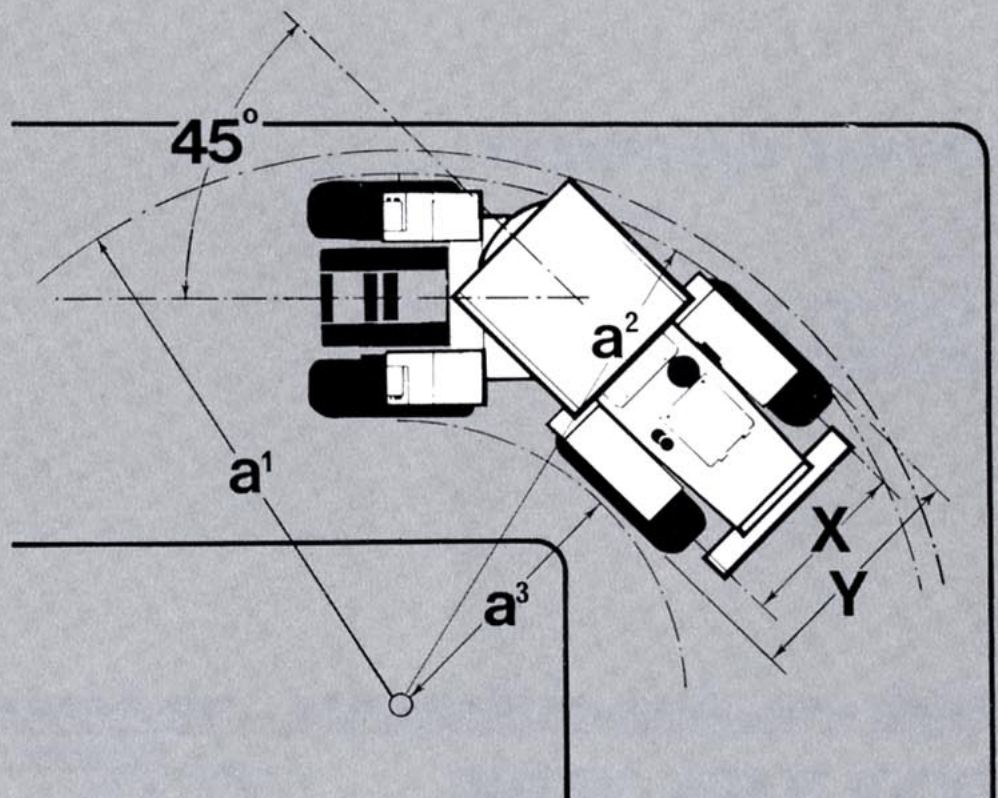

The specifications apply for a machine and tyres 15.5-25/12.

Alternative tyres	Adjustment of basic data		Adjustment of machine weight
	Width over wheels	Ground clearance	
14.9-24L2	-10 mm (+0.4 in)	±0	-400 kg (-880 lb)

STANDARD EQUIPMENT



Safety and comfort

- Electric engine block heater
- Rear-view mirrors, two, external
- Rear-view mirror, one, internal
- Cigarette lighter, ashtray
- Attachments for seat belt
- Utility box, glove compartment in cab
- ROPS safety cab as per ISO 3471 and SS 783
- Cab heater with defroster, filtered fresh air intake
- Instrument panel with symbol markings
- Turn signal indicators
- Lifting eyes for shipping
- Tyre inflation connection
- Horn
- Safety start
- Sun visor
- Fenders
- Roof hatch
- Hazard flashers
- Tool kit
- Windshield wipers, front and rear
- Heated operator's seat



Engine and electrical system

- Brake pressure gauge
- Fuel gauge
- Lighting: Driving lights, asymmetrical high/low/parking lights, working lights front and rear, side marker lights, brake lights, cab lighting, instrument lighting
- Master switch, electrical system
- Pilot lamps for: working lights front and rear, battery charging, turn signals, hazard flashers, central warning lamp, driving brakes, high beam, cold start, air cleaner filter, engine oil pressure, parking brake, hydraulic transmission oil pressure
- Engine temperature gauge
- Transmission temperature gauge
- Air cleaner
- Electrical outlet for inspection lamp
- Alternator
- 7-pole trailer connector



Power transmission

- Full power shift transmission
- Single-lever control
- Disengagement valve for transmission



Hydraulic system

- Control valve (3 sections)
- Third hydraulic function

OPTIONAL EQUIPMENT

- Working lights, front
- Tow hitch
- Air conditioning
- Inspection lamp
- Speedometer/odometer
- Tyres 15.5—25 or 14.9—24
- Heavy-duty air cleaner
- LP-gas or blowlamp engine heater
- Hose for tyre inflation
- Protective grilles for working lights
- Seat belt
- Rotating warning beacon, collapsible
- Windshield washers
- Tool box

VOLVO BM

VOLVO BM AB ESKILSTUNA SWEDEN

Under our policy of continuous product improvement, we reserve the right to change specifications and design without prior notice. The illustrations do not necessarily show the standard version of the machine.

Ref.No. 21 1 669 1505
ENGELSKA

Production group for basic printed matter Volvo BM
Pneum. Förl. Grupp