

VOLVO BM 1240



Specification Volvo BM Loader 1240

POWER

Volvo D70B, diesel engine 118 kW (160 HP)

CAPACITY

Tight turning radius, fast working cycles — quick and responsive to operate. Big penetration and traction ensure fast bucket filling

STABILITY

Large wheels. Excellent weight distribution

ECONOMY

Low fuel consumption. Long-life components

SAFETY-COMFORT

Outstanding driver comfort — ROPS safety cab as standard — fingertip servo-controls — low noise level.





ENGINE

Volvo D70B

Output flywheel	107 kW at 42 r/s, DIN 70020 (145 hp at 2500 r/m)
Output	118 kW at 42 r/s, SAE J 270 (160 hp at 2500 r/m)
Max torque	462 Nm at 27 r/s, DIN 70020 (47 kpm at 1600 r/m) 490 Nm at 30 r/s, SAE J 270 (49.8 kpm at 1600 r/m)
Bore	104.7 mm (4.1 in)
Stroke	130 mm (5.1 in)
Number of cylinders	6
Displacement	6.7 lit (409 cu in)

The D70B engine with direct injection has replaceable wet cylinder liners, light metal pistons and a crankshaft carried in seven bearings. The engine air cleaning system cleans the intake air in three stages:

1. Cyclone precleaner with automatic dust ejection through the exhaust pipe.
2. Large replaceable paper filter with cab mounted indicator.
3. Replaceable safety element.



ELECTRICAL SYSTEM

Voltage	24 V
Alternator	25 A (700 W)
Battery	2 x 12 V, 125 Ah
Starter motor	3 kW (4 hp)

The alternator ensures efficient battery charging, even at low engine speed. The powerful starter motor gives easy cold-weather starting. Travelling and working lights permit safe and efficient work in the dark. Fuse panel is well-protected and easily accessible inside the cab.



TORQUE CONVERTER

Single-stage, single-phase torque converter.
Torque multiplication ratio 2.9:1



TRANSMISSION

Full power shift 4-speed transmission.

Maximum speeds forward and reverse with 20.5–25 tyres	1st	6 km/h	3.7 mph
	2nd	13 km/h	8.0 mph
	3rd	30 km/h	18.6 mph
	4th	42 km/h	26.0 mph



AXLES

Front:	Volvo BM AH 60
Rear:	Volvo BM AH 51

Free floating axle shafts carry torque, not machine weight, and incorporate planetary hub reductions. The front axle is equipped with differential lock as standard. The long wheelbase, the big wheels and rear axle oscillation up to 400 mm (16") contribute towards the outstanding stability and go-anywhere mobility.



BRAKES

Service brake

All wheels are equipped with air over hydraulic, self-adjusting disc brakes. For maximum safety, the brake system is split into two independent circuits — one for the front wheels and one for the rear wheels.

Parking brake, mechanical on transmission shaft.



TYRES

Choice of 20.5–25/16 — L2, L3
23.5–25/16 — L2, L3



STEERING

Centre-point frame articulation
Steering angle $\pm 40^\circ$
Turning radius (a_2) 5.2 m (17 ft)
(over tyres)

Pump
Pump output

Gear-type design
95 lit (21 Imp gal)/min at 10 MPa
(1420 PSI) and 2400 r/m
Relief pressure 14 MPa (1990 PSI)

Relief pressure

The design of the steering system provides easy smooth steering without bumps and jolts being felt through the wheel. The system provides approved emergency steering.



HYDRAULIC SYSTEM

Pump:
Pump output

Gear-type design
250 lit (55 Imp gal)/min at 10 MPa
(1420 PSI) and 2400 r/m
Relief pressure 14 MPa (1990 PSI)

Relief pressure

Cylinders

Lift — bore and stroke	145 x 968 mm (5.7 x 38 in)
Tilt — bore and stroke	125 x 490 mm (4.9 x 19.3 in)
Raise	7.2 sec
Lower	5.1 ..
Dump	2.8 ..

Control valve

Three spool valve with built-in pressure relief valve.

Functions

1. Lift — float position with hold lock
2. Tilt
3. Attachment or external hydraulics

The hydraulic system is equipped with a 3rd hydraulic spool as standard and complete 3rd and 4th function can easily be added. The control valve is pilot-operated. The hydraulic oil tank is extra large for maximum cooling of the oil. The vented air in the tank passes through the engine air cleaner.



SERVICE REFILL CAPACITIES

Cooling system	28 lit (6.1 Imp gal)
Crankcase	17 lit (3.7 Imp gal)
Transmission and torque converter	25 lit (5.5 Imp gal)
Front axle differential and hubs	36 lit (7.9 Imp gal)
Rear axle differential and hubs	32.6 lit (7.2 Imp gal)
Hydraulic system	260 lit (57.2 Imp gal)
Hydraulic tank	185 lit (40.7 Imp gal)
Fuel tank	230 lit (50.6 Imp gal)



CAB

The all-welded ROPS cab has two lockable doors and a roof hatch. The cab is approved in accordance with ROPS standards (SAE J394). The operator's station is ergonomically designed, with all controls and pedals located and designed for quick and easy operation. The operator's seat is fully adjustable. In its standard version, the cab is equipped with an efficient heating and ventilation system, with front and side window defrosters. The cab is mounted on the chassis via rubber pads, thereby minimizing the noise level inside the cab.

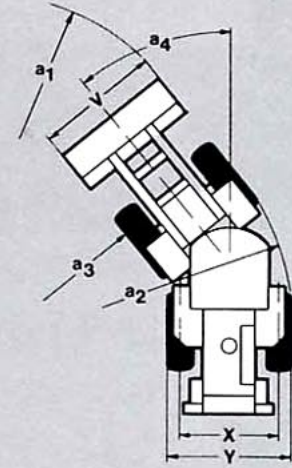
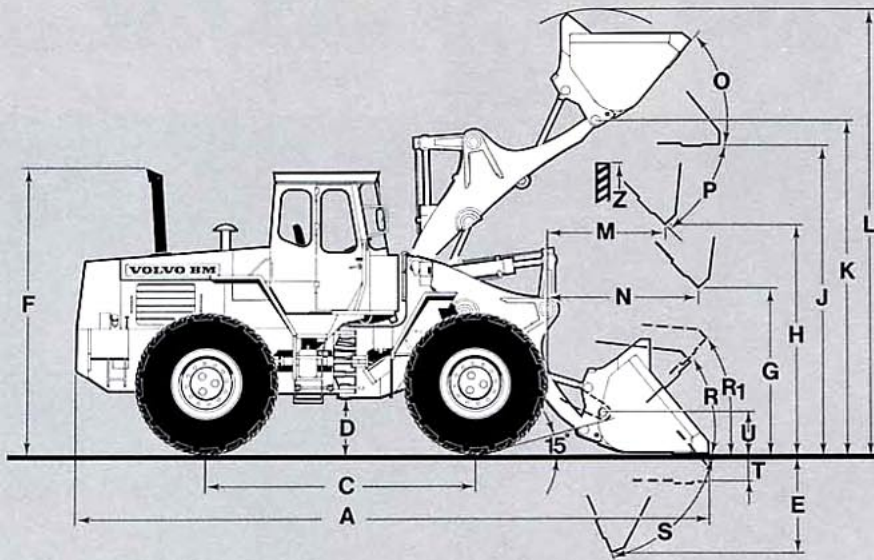

DIMENSIONS

A = 6800 mm (22'4")
 C = 3000 mm (9'10")
 D = 450 mm (17'7")
 E = 1010 mm (3'4")
 F = 3050 mm (10')
 G = 2130 mm (7')
 H = 3010 mm (9'10")
 J = 3750 mm (12'4")
 K = 3960 mm (12'11")
 L = 5120 mm (16'9")

M = 1000 mm (3'3")
 N = 1700 mm (5'7")
 O = 50°
 P = 42°
 R = 41°
 R₁ = 43° Carry position
 S = 52°
 T = 130 mm (5")
 U = 350 mm (13'8")
 V = 2500 mm (8'2")

X = 1960 mm (6'5")
 Y = 2490 mm (8'2")
 Z = 3700 mm (12'2") bucket
 Z = 3700 mm (12'2") log grapple

a₁ = 5870 mm (19'3")
 a₂ = 5255 mm (17'3")
 a₃ = 2765 mm (9'1")
 a₄ = ±40°

Dimension change with 23.5–25 tyres: vertical 50 mm (2")
 horizontal 50 mm (2")
 width over bucket 2700 mm (8'10")
 width over tyres 2650 mm (8'8")

Operating specification

Attachment		Bucket pin on	Bucket hook on	Bucket pin on	Bucket hook on
		2.1 m ³ (2.75 cu yd)	2.1 m ³ (2.75 cu yd)	2.5 m ³ (3.25 cu yd)	2.5 m ³ (3.25 cu yd)
Dump clearance at full lift 45° discharge (H)	mm (ft in)	3010 (9'10")	2950 (9'8")	2940 (9'8")	2880 (9'5")
Reach at full lift and 45° discharge (M)	mm (ft in)	1000 (3'3")	1080 (3'6")	1070 (3'6")	1150 (3'9")
Reach at 45° discharge and 7 ft height (N)	mm (ft in)	1700 (5'7")	1720 (5'8")	1770 (5'9")	1790 (5'10")
Overall length (A)	mm (ft in)	6800 (22'4")	6900 (22'8")	6900 (22'8")	7000 (23')
Overall height with attachment (L)	mm (ft in)	5120 (16'9")	5180 (17')	5120 (16'9")	5180 (17')
Loader clearance circle (over bucket a ₁)	mm (ft in)	11740 (38'6")	11800 (38'8")	11740 (38'6")	11800 (38'8")
Width (over bucket V)	mm (ft in)	2500 (8'2")	2500 (8'2")	2500 (8'2")	2500 (8'2")
Breakout force	kg (lb)	8700 (19180)	8000 (17640)	7975 (17580)	7330 (16160)
Static tipping load, straight	kg (lb)	8800 (19400)	8300 (18300)	8700 (19180)	8200 (18080)
Static tipping load at 35° turn	kg (lb)	7850 (17300)	7450 (16420)	7750 (17090)	7350 (16200)
Static tipping load at full (40°) turn	kg (lb)	7700 (16980)	7300 (16090)	7600 (16760)	7200 (15880)
Operating load	kg (lb)	3850 (8490)	3650 (8050)	3800 (8380)	3600 (7940)
Operating weight	kg (lb)	12400 (27340)	12600 (27780)	12500 (27560)	12700 (28000)

Specifications are based on a machine equipped with all standard equipment, 20.5–25/16 L2-radial tyres and bucket as indicated. Wherever applicable, specifications are in accord-

ance with SAE Standards J 732 c and J 742 b. Specifications and design are subject to change without further notice.

Optional tire equipment	Change in basic data		Change in static tipping load			
	Width over tyres	Ground clearance	Operating weight (kg/lb)	0°	35°	Full turn (kg/lb)
20.5–25/16 L3	±0	±0	170 (375)			100 (220)
23.5–25/16 L2	+200 mm (8")	+50 mm (2")	560 (1235)			350 (770)
23.5–25/16 L3	+200 mm (8")	+50 mm (2")	770 (1700)			450 (1000)
20.5–25/16 L2 with 75% CaCl ₂ (rear tyres)	±0	±0	820 (1810)			1000 (2200)

STANDARD EQUIPMENT



Safety and comfort

- ROPS safety cab
- Instrument panel with symbols
- Utility basket in cab
- Mounting for safety belt
- Cigarette-lighter
- Ashtray
- Horn
- Heating and ventilation system with defroster
- Sun visor
- Safety start
- Pressure gauge for air brakes
- Comfort seat
- Lights:
 - Headlights, high/low beam
 - Parking lights
 - Working lights forward and rear
 - Brake lights
 - Tail lights
 - Cab lighting
 - Instrument lighting
 - Turn signal indicators
 - Hazard flashers
- Windshield wipers, front and rear
- Rear-view mirrors, external
- Fenders
- Tyre inflation connection
- Tool kit



Engine and electric system

- Battery disconnect switch
- Gauges and indicators:
 - Engine temperature
 - Engine oil pressure
 - Battery charging
 - Air filter service
 - Fuel
- Torque converter-oil temperature
- Transmission oil pressure
- Low brake pressure
- Parking brake
- Hour meter
- Working lights
- Inspection lamp outlet
- Compressed air outlet
- Muffler
- Alternator



Power train

Power shift transmission
 Single lever control
 Transmission cut-out valve
 Differential lock on front axle
 Tyres 20.5—25/16
 4-wheel drive disconnect



Hydraulic system

3-spool control valve pilot operated
 Bucket position indicator

OPTIONAL EQUIPMENT

- Extra fuel filter (in addition to standard)
- Spark-arresting muffler
- Heavy-duty air cleaner
- Engine block heater: electric or propane
- Speedometer/odometer
- Alternative types of tyres
- 3rd hydraulic piping
- 4th hydraulic function
- Hydraulic outlet
- Winch
- Extra working lights
- Air conditioner
- Underbody protection plates
- Towing hitch
- Inspection lamp
- Tinted glass on cab
- Cab ventilator
- Cab ventilator with heating
- Lifting eyes for shipping
- Attachment bracket with quick-change coupling: mechanical or hydraulic locking
- Protective screen for lights, front and rear
- Compressed air outlet at rear of machine
- Safety belt
- Rotating beacon, with or without collapsible mounting bracket
- Automatic lubrication system
- Tyre inflation kit
- Bucket positioner and boom kick out

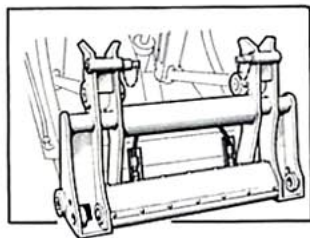

"Quick-change" coupling system

The Volvo BM 1240 may be delivered with quick-change coupling for either hydraulic or mechanical locking as optional equipment to fully utilize the wide range of attachments available.

VOLVO BM

VOLVO BM AB ESKILSTUNA SWEDEN

The manufacturers reserve the right to change specification or design without prior notice. Illustrations do not necessarily show the machine in its standard version.

Ref. No. 21 1 669 1393
ENGELSKA

Production group for basic printed matter Volvo BM
 Photo Studio Roland