



**VOLVO BM
1240**

VOLVO BM 1240 – a fast, well-balanced 12-tonner

Step up into the cab of a VOLVO BM 1240. You'll find it luxuriously comfortable, with controls and levers well-positioned for easy, efficient operation. Visibility is excellent from all sides of the safety cab. The 1240 is designed for optimum driver performance. Start the powerful engine and try loading in a hard-packed gravel bank. Then you'll realize just how well-balanced the 1240 really is. The VOLVO diesel engine, the transmission, the large wheels and the loader unit hydraulics are ideally matched to one another, providing ample penetration and break-out force when you really need it. And this means that the VOLVO BM 1240 can keep up a fast workrate on the toughest jobs.

Fast and stable

The power from the 160 hp VOLVO engine is transmitted through a perfectly balanced power-shift transmission. This gives the 1240 remarkably good acceleration. In combination with the long wheelbase and the low centre of gravity, the power from the engine can be exploited to the full to achieve high average speeds and a stable ride.

Sturdy construction

Tried and tested production line components, high quality raw materials and precision manufacture characterize the construction of the VOLVO BM 1240. It is a heavy-duty machine in all respects, in order to withstand heavy stresses. This ensures reliable, trouble-free operation with minimum maintenance.

Easy to operate

The 1240 is easy to drive and the high-class cab provides a pleasant, comfortable working environment for the driver. And a happy driver works more efficiently. The machine is easy to steer and gears are easy to shift. The loading unit is also easy to operate. All of these factors enable the driver to get the most out of the machine and achieve maximum productivity.

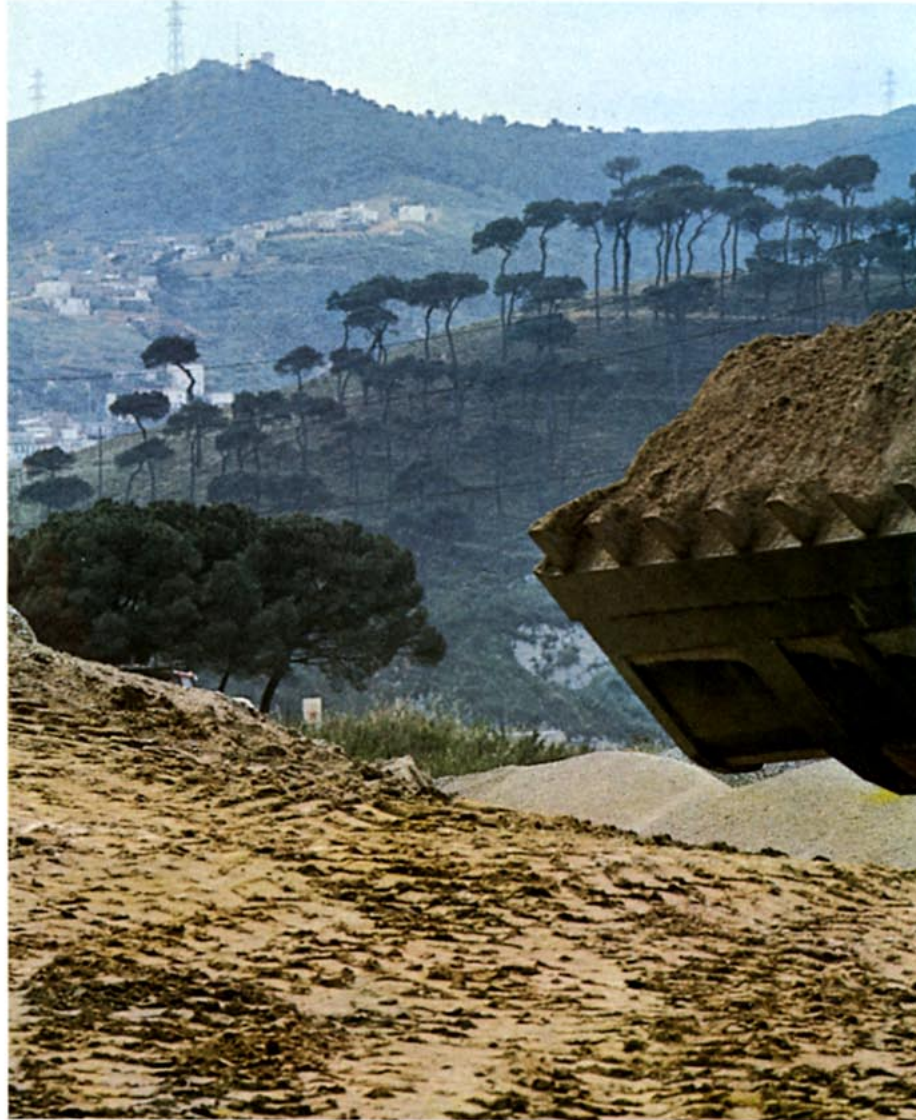

Safe, roomy and luxuriously comfortable cab.

Well-balanced and ruggedly designed. Long wheelbase and big wheels.

Short working cycles thanks to generous outreach and good acceleration.



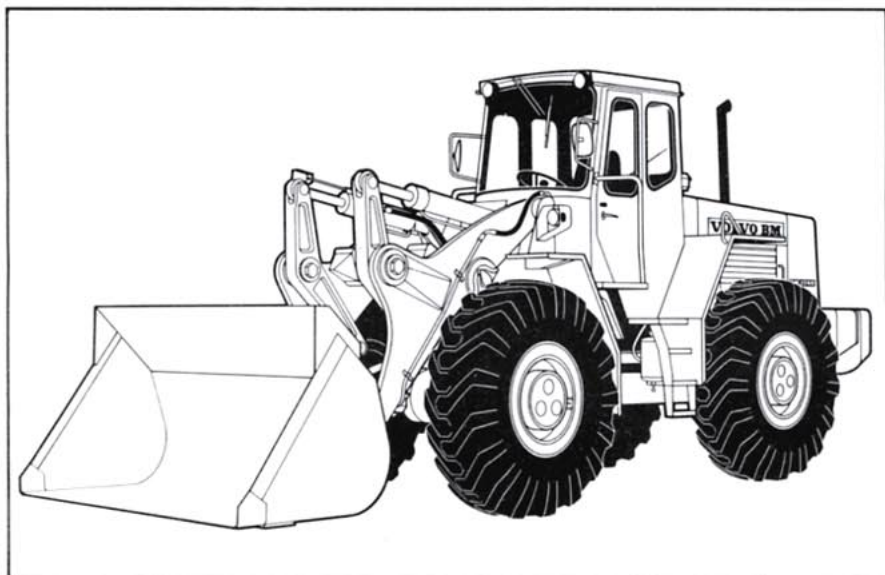

From engine to useful pulling power...

The power source in the 1240 is the powerful, reliable VOLVO D 70B engine – rugged and dependable. The engine has 6 cylinders with a total displacement of 6.73 litres and develops 118 kW SAE at 45 rev/s (160 hp SAE at 2 500 rev/min). The D 70B is direct-injected and has wet, replaceable cylinder linings. The pistons are made of light-alloy metal and the crankshaft is carried in 7 bearings with all bearings surface-hardened for long life.

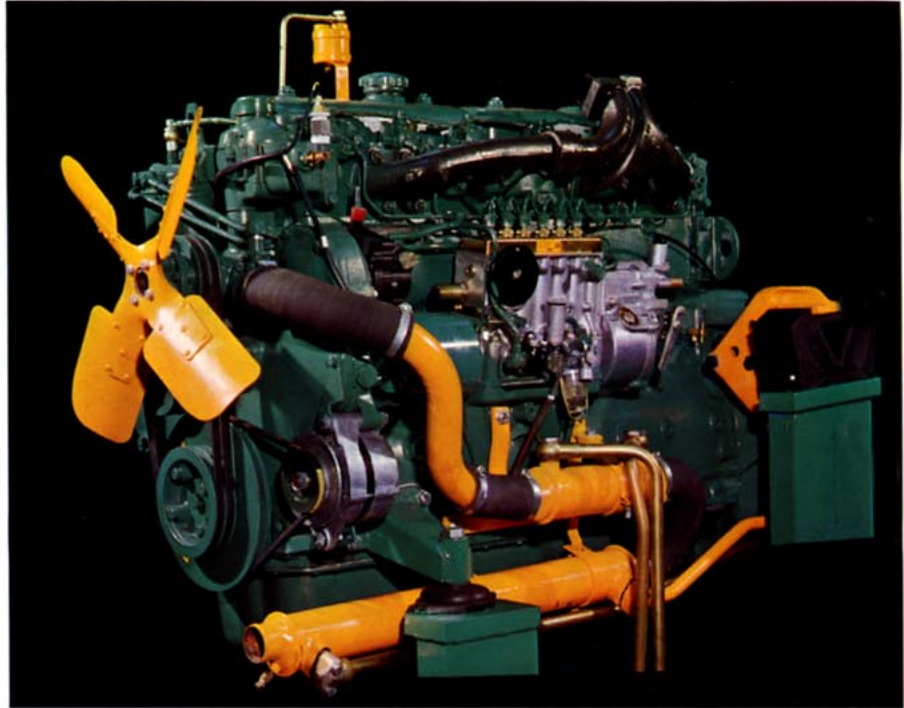

VOLVO D 70B diesel engine.

Well-balanced power pack

The engine, the power-shift gearbox, the torque converter, the drive shafts and the final drives combine to form a well-balanced, integrated power pack. Engine power is converted into optimum machine performance with maximum efficiency. The torque converter automatically increases the torque by a factor of up to 2.9, resulting in a corresponding increase in the machine's tractive power and penetration capacity. The power-shift gearbox has one planetary gear train for each gear. The driver can shift smoothly throughout the entire range and can change directions even at high engine speed. The planetary-type final drives in the wheel hubs relieve the drive shafts of stresses.

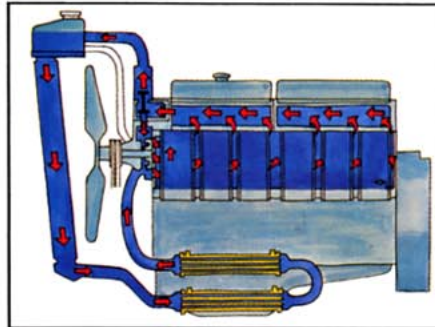

A constant working temperature is of great importance for long engine life. The cooling system is carefully designed with high-lying distribution channels for efficient cooling of the hottest parts of the engine. The transmission and engine each have their own high-capacity oil cooler.

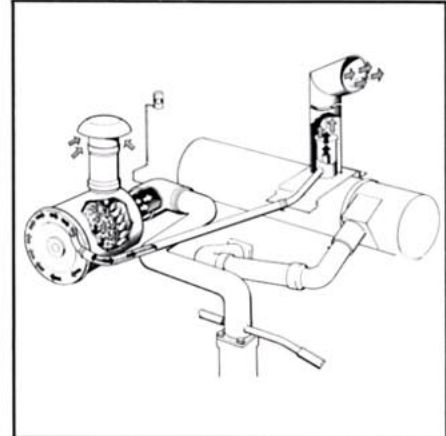

The engine air filter has a high collection efficiency – about 99.8 %.

Air is cleaned in two changes:

1. In a cyclone-type pre-cleaner with automatic discharge through an ejector on the exhaust pipe.
2. Through a large replaceable filter cartridge. The system also includes a coarse filter.



Plenty of pulling power – thanks to the powerful engine and the large wheels.

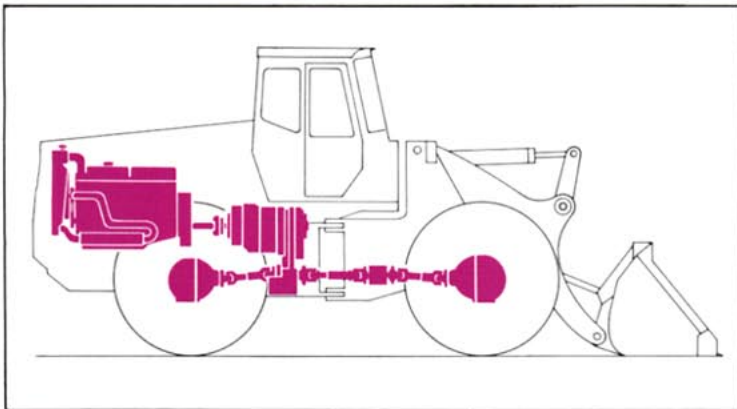

The 1240 is sturdy and can take tough handling. The power pack is well-balanced and composed of tried and tested quality components – carefully designed and ideally suited to their functions.



Easy to shift gears – all gears on one lever.

All gears on one lever

Forward . . . reverse . . . 1st . . . 2nd . . . 3rd . . . 4th . . . – all on a single lever. Electronic gear-shifting makes for real fingertip control and quick response. This extra convenience feature is just one of the reasons for the 1240's high production capacity.

A firm grip on the ground

The 1240 is equipped with a lock-up differential on the front axle. If one wheel starts to lose its grip on the ground, for example under slippery conditions, the tractive force on the other wheel automatically increases. The result is constant, positive traction and reduced tyre wear.



Long transport distances – high capacity

The 1240 has high capacity even over long transport distances. Its large wheel base ensures a stable ride without unnecessary bucket spill when, for example, material is being hauled to screening plants or crushers. And because the 1240 has such good acceleration and the power necessary to maintain high average speeds, transport times are reduced.



40

25



2

Built for when the going gets rough

The VOLVO BM 1240 is very sturdily built. The frame sections are made of high-tensile Swedish steel – specially developed for machines which operate under severe driving conditions with heavy loads and stresses. All welds are horizontal, guaranteeing optimum joint strength. The front frame section is built up of four vertical steel plates between which the lifting cylinders are mounted. In this way, the cylinders are well-protected in the box sections and there are no uneven loads on bearings and brackets.

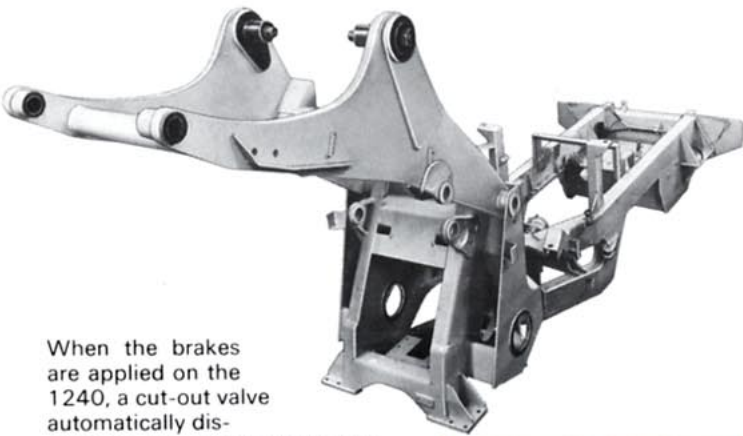

When the brakes are applied on the 1240, a cut-out valve automatically disengages the engine from the transmission so that all the engine power is diverted to the hydraulic pump. This lends more muscle to the hydraulics. The loader unit can work faster, increasing the machine's productivity. The cut-out valve is operated from inside the cab.

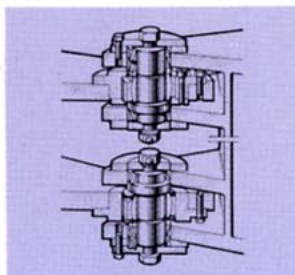

Heavy-duty articulation joint.



The 1240 is designed throughout to take heavy stresses.



Different types of jobs – no problem. The 1240 can be equipped with a wide variety of different buckets and implements . . .



Efficient, durable loader unit

It's easy to manoeuvre the load – maximum outreach at 2 m height and tipped bucket is nearly 1.8 m (6 ft) and lifting height under level bucket is nearly 3.8 m (12.5 ft). The powerful hydraulics permit rapid movements, and automatic bucket operation is standard for even higher efficiency. The driver can easily select the optimum bucket angle and discharge height for the job at hand. The loader unit is sturdily constructed and has unusually large bearing surfaces. Self-aligning bearings are provided at points subjected to especially high stresses – a design feature which enables the loader unit to stand up to hard use while requiring less maintenance.



Self-aligning bearings are provided at points subjected to especially high stresses – bearings which follow the movements of the machine.

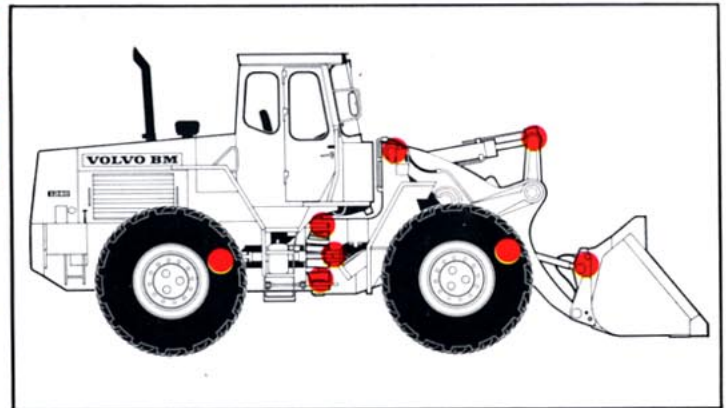

Self-aligning linkage bearings provide excellent durability.



... and thanks to the quick-coupling on the attachment bracket, you can change attachments in less than a minute to prepare the machine for new duties.

Full tractive force even over rough terrain

The heavy-duty rear axle has a high point of attachment, which permits the axle to oscillate through a range of 30°. As a result, the 1240 can keep going over rough terrain without losing traction and with maximum tractive force on all wheels.

Safe brake system

Pneumatically operated brakes on all wheels. The system is split into two circuits for maximum safety.

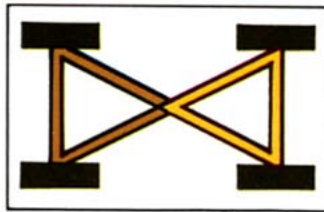

Dual-circuit brake system.



Large rear-axle oscillation.

Non-skid steps, sturdy railings and wide doors make it easy and safe to get in and out of the 1240 cab.



The comfort seat can be adjusted to any position for maximum individual driving comfort. It can be moved fore and aft and the angle of the backrest can be adjusted to different positions. The seat springs can be adjusted according to the weight of the driver.



The driver is safe and secure in the steel safety cab and has excellent allround visibility.

A superb cab

The 1240 cab is spacious and pleasant. Great care has been devoted to insulation and anti-vibration mountings. The sound level in the cab is therefore very low. The heating and ventilating system is very efficient and maintains a pleasant inside temperature even at very low outside temperatures. For hot summer days, the cab can be equipped with a cab ventilator or an air-conditioning unit (extra). All controls and pedals are located and designed for quick and convenient operation of the machine in all situations. The 1240 cab is the driver's idea of comfort and performance.



Richly appointed, easy-to-read instrument panel.



Continuous research, detailed measurements and long-range testing precede the introduction of a new VOLVO BM product. To ensure safety, quality and economy.

Designed for simple service

It is VOLVO BM tradition that development and design work be carried out in continuous consultation between service engineers and designers. In this way, each detail of the final product is easy to service and is of a strictly functional technical nature.



The 1240 has a safety cab which conforms to the stringent standards of the Swedish Board of Industrial Safety. These standards prescribe impact testing and lay down requirements on space, seating, sound level and heating/ventilation. The cab has also passed the American ROPS test with flying colours. A plate inside the cab certifies that the cab has been approved in accordance with these respective standards.

Tested for maximum safety

In the American ROPS test as per SAE J 394 A, the frame and cab are mounted in a fixed position. The cab is then subjected to vertical and horizontal press forces calculated on the basis of the weight of the machine. The 1240 has passed this test with flying colours.

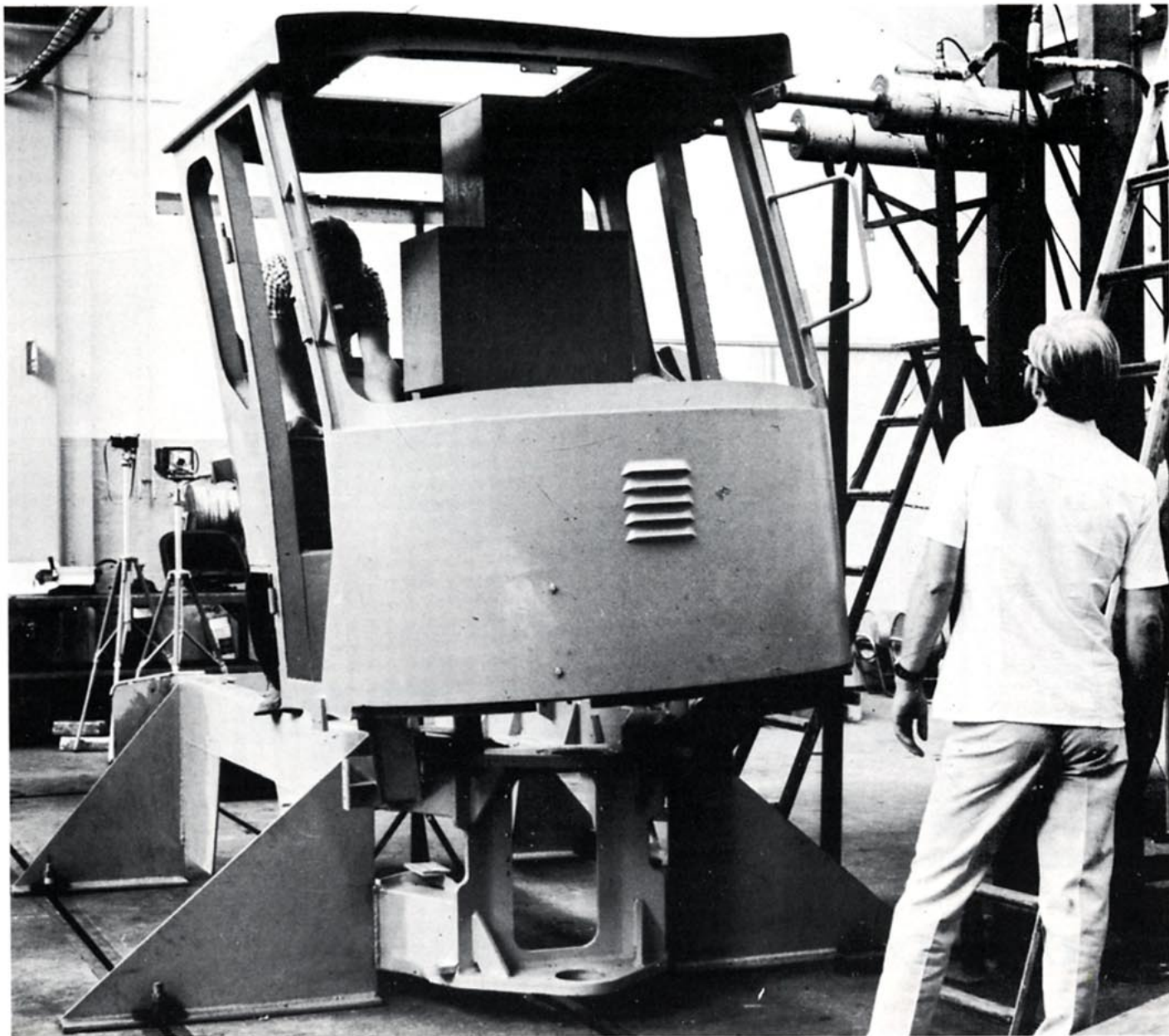



The VOLVO BM 1240 is one of VOLVO BM's range of heavy loaders – the best-selling loaders in Europe. This success can be attributed to built-in Swedish quality and many years of technical experience from the development and production of construction machinery.

VOLVO BM

VOLVO BM AB ESKILSTUNA SWEDEN

**Ref. No. 21 1 669 1149
ENGELSKA**