

VOLVO BM 622/642



Specification Volvo BM loader 622/642

ECONOMY

The Volvo BM 622 and 642 are reliable machines, composed of time-tested and durable components. They provide a high yield from each operating hour with a minimum of service and low fuel consumption.

CAPACITY/POWERFUL ENGINE

The machines are quick and efficient, thanks to a new powerful engine and a loader unit with high lifting height and long reach. Nimble and manoeuvrable, they are easy to operate.

ALLROUND

A wide range of attachments together with a hydraulically operated attachment bracket permit rapid changes between different work duties.

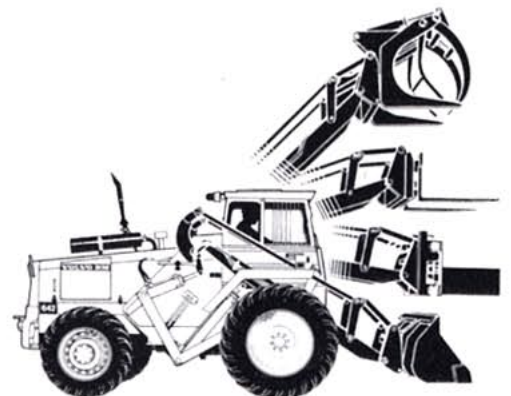



ENGINE

The Volvo BM D45 engine is a direct-injected, 4-stroke diesel engine with overhead valves and wet replaceable cylinder linings plus a balancing device for vibrationless operation.

Flywheel rating	55.5 kW at 38.3 rps DIN 70020 (75.5 hp at 2300 rpm DIN)
Gross rating	60 kW at 38.3 rps SAE J 270 (81.5 hp at 2300 rpm SAE)
Max. torque	286 Nm at 21.7 rps DIN 70020 (211 lbf ft at 1300 rpm DIN) 297 Nm at 21.7 rps SAE J 270 (219 lbf ft at 1300 rpm SAE)
No. of cylinders	4
Bore	105.57 mm (4.2 in)
Stroke	128 mm (5.0 in)
Displacement	4.48 litres (273 in ³)

The intake air is cleaned in three stages:

1. Cyclone precleaner with automatic dust ejection through the exhaust
2. Large replaceable paper filter with cab-mounted indicator
3. Replaceable catch-all filter



ELECTRICAL SYSTEM

Battery	2 x 12 V (connected in series)
Voltage	24 V
Battery capacity	96 Ah
Alternator	700 W (25 A)
Starter motor	3 kW (4 hp)



TORQUE CONVERTER

Type	Single-stage, single-phase
Torque multiplication ratio	3.3:1



TRANSMISSION

Volvo BM gearbox with power shift. The transmission has four gears forward and four reverse.

Designation HT 65

Speeds:	1. 0–7 km/h (0–4.4 mph)
	2. 0–12 km/h (0–7.5 mph)
	3. 0–19 km/h (0–11.8 mph)
	4. 0–30 km/h (0–18.6 mph)



AXLES

Front axle:	Volvo BM with final drives located in a central final drive housing. Differential lock 100 % lock-up (dog clutch)
Rear axle 622:	Oscillation $\pm 12^\circ$ (380 mm)
642:	Oscillation $\pm 11^\circ$ (320 mm)



BRAKES

Driving brakes

Hydraulic, encapsulated disc brakes, located before the final drives.

Steering brake actuated by brake pedal via an automatic reciprocal selector valve.

Parking brake, mechanically operated.



TYRES

Alternatives

Front	16.9–30/14	Rear	12.5–20/10	622
	16.9–30/14		12.4–24/12	642
	23.1–26/12		11.25–24/8	622/642
	18.4–30/12		12.5–20/10	622



STEERING SYSTEM

Rear wheel steering. Hydraulic with two double-acting hydraulic cylinders.

Oil pump, type	gear pump
622: Output at 5 MPa (725 psi) and 2300 rpm (38.3 rps)	32 l/min (7 Imp gal/min)
642: Output at 9 MPa (1305 psi) and 2300 rpm (38.3 rps)	32 l/min (7 Imp gal/min)
622: Relief pressure	5 MPa (725 psi)
642: Relief pressure	9 MPa (1305 psi)



HYDRAULIC SYSTEM

Pump, type	gear pump
Output at 11.5 MPa (1668 psi) and 2300 rpm (38.3 rps)	77 l/min (16.9 Imp gal/min)
Relief pressure	11.5 MPa (1668 psi)
Hydraulic cylinders:	
Lift cylinders – bore/stroke	110 x 895 mm (4.3 x 35.2 in)
Tilt cylinders – bore/stroke	110 x 335 mm (4.3 x 13.2 in)
Lifting time	5.4 s
Lowering time	3.3 s
Forward/backward tilt	1.8/2.3 s

Control valve:

Valve with three slides and built-in relief valve.

Functions	1. Tilt
	2. Lift – float with hold
	3. Attachment or external hydraulics



SERVICE REFILL

	Litres	Imp.gal	US gal
Cooling system	16	4.2	3.5
Engine	10.5	2.8	2.3
Transmission and torque converter	22	5.8	4.8
Transmission and torque converter at change	16	4.2	3.5
Final drive and differential housing	50	13.2	11.0
Hydraulic system	90	23.8	19.8
Hydraulic tank	77	20.3	16.9
Fuel tank	115	30.3	25.3



CAB

The cab is mounted on rubber pads, insulated and weathertight and has a flat floor with a rubber mat. It has been examined and approved by the Swedish

Board of Occupational Safety and Health, which includes impact testing in accordance with OECD requirements. It also fulfils SAE-ROPS requirements. The cab has three exits: door, roof hatch and rear window. Controls and pedals are located and designed for convenient and quick operation. Operator's seat with adjustable backrest and springs. Fresh-air cab heater.

DIMENSIONS STRAIGHT BUCKET WITHOUT TEETH

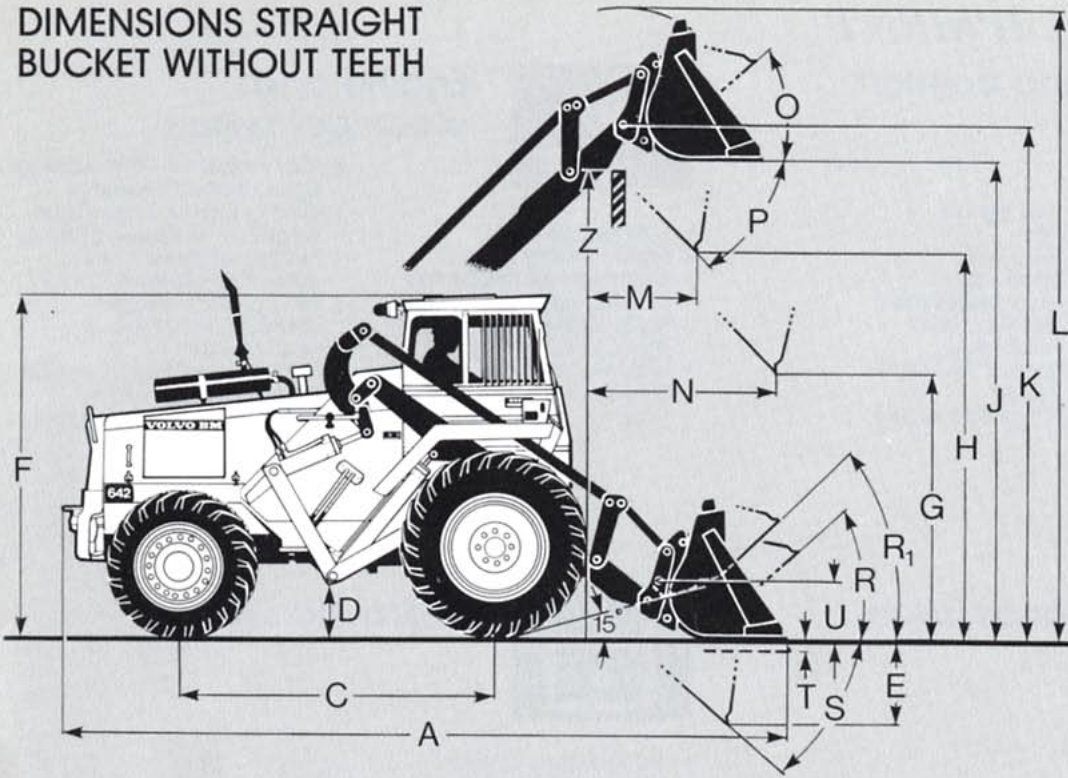

A	See table	H	See table	O	41°	T	100 mm (4")
C	2380 mm (7'10")	J	3600 mm (11'10")	P	45°	U	450 mm (1'6")
D	350 mm (1'2")	K	3850 mm (12'8")	R	42°	Z	3530 mm (11'7")
E	710 mm (2'6")	L	See table	R ₁	44° (carry pos.)		
F	2640 mm (8'8")	M	See table	S	42°		
G	2000 mm (6'7")	N	See table				

The specifications pertain to a standard machine equipped with a 1.0 m³ (1.3 yd³) straight bucket without teeth and tyres 16,9—30/14 front and 12.5—20/10 rear for the 622 and 12.4—24/12 for the 642.
Where applicable, the specifications conform to SAE standards J 732 c and J 742 b.

DIMENSIONS TURNED MACHINE

622

v = See table
 x = Front 1820 mm (6')
 Rear 1804 mm (5'11")
 y = 2250 mm (7'5")
 Swept radius, a₁ = See table
 Turning radius, a₂* = 5250 mm (17'3")
 Inner radius, a₃ = 2500 mm (8'2")

642

v = See table
 x = Front 1820 mm (6')
 Rear 1850 mm (6'1")
 y = 2250 mm (7'5")
 Swept radius, a₁ = See table
 Turning radius, a₂* = 5600 mm (18'4")
 Inner radius, a₃ = 2800 mm (9'2")

*J With aid of steering brakes about 3.3 m (130 in).

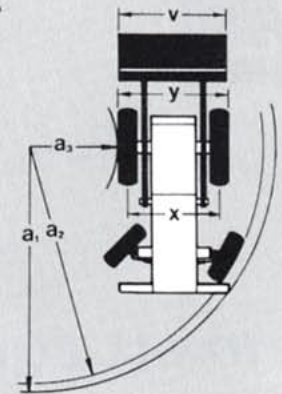

MACHINE CAPACITY

Attachment		Straight lip without teeth	Straight lip with teeth	Grading bucket	Light materials bucket	
Capacity		1.0 m ³ (1.3 yd ³)	1.0 m ³ (1.3 yd ³)	1.4 m ³ (1.8 yd ³)	2.1 m ³ (2.7 yd ³)	
(H) Max. dump height under 45° forward-tilted bucket	mm (ft in)	2900 (9'6")	2800 (9'2")	2530 (8'4")	2600 (8'6")	
(M) Reach at max. dump height under 45° forward-tilted bucket	mm (ft in)	750 (2'6")	950 (3'1")	1140 (3'9")	1050 (3'5")	
(N) Reach at 2 m dump height under 45° forward-tilted bucket	mm (ft in)	1400 (4'7")	1400 (4'7")	1550 (5'1")	1490 (4'11")	
(A) Overall length	mm (ft in)	5550 (18'3")	5680 (18'8")	6050 (19'10")	5950 (19'6")	
(L) Max. height	mm (ft in)	4700 (15'5")	4700 (15'5")	4700 (15'5")	5000 (16'5")	
(a ₁) Swept radius 622/642	mm (ft in)	5300/5700 (17'5"/18'8")	5300/5700 (17'5"/18'8")	5300/5700 (17'5"/18'8")	5300/5700 (17'5"/18'8")	
(V) Width over attachment	mm (ft in)	2350 (7'9")	2350 (7'9")	2350 (7'9")	2350 (7'9")	
Breakout force	kg (lb)	4200 (9259)	4200 (9259)	2600 (5732)	2800 (6173)	
Tipping load, straight	kg (lb)	3300 (7275)	3250 (7165)	2950 (6503.5)	3100 (6834)	
Working load	kg (lb)	1650 (3637.5)	1625(3582)	1475 (3252)	1550 (3417)	
Machine weight 622/642	kg (lb)	8000 (13227)	8050 (17747)	8100 (17852)	8100 (17852)	
Weight distribution with bucket in carrying position	Front	kg (lb)	4500 (9921)	4575 (10086)	4700 (10362)	4670 (10295.5)
	Rear	kg (lb)	3500 (7716)	3475 (7661)	3400 (7496)	3430 (7562)

DIMENSIONS WITH CRANE JIB

(Crane jib 98616 hydraulic pivot)

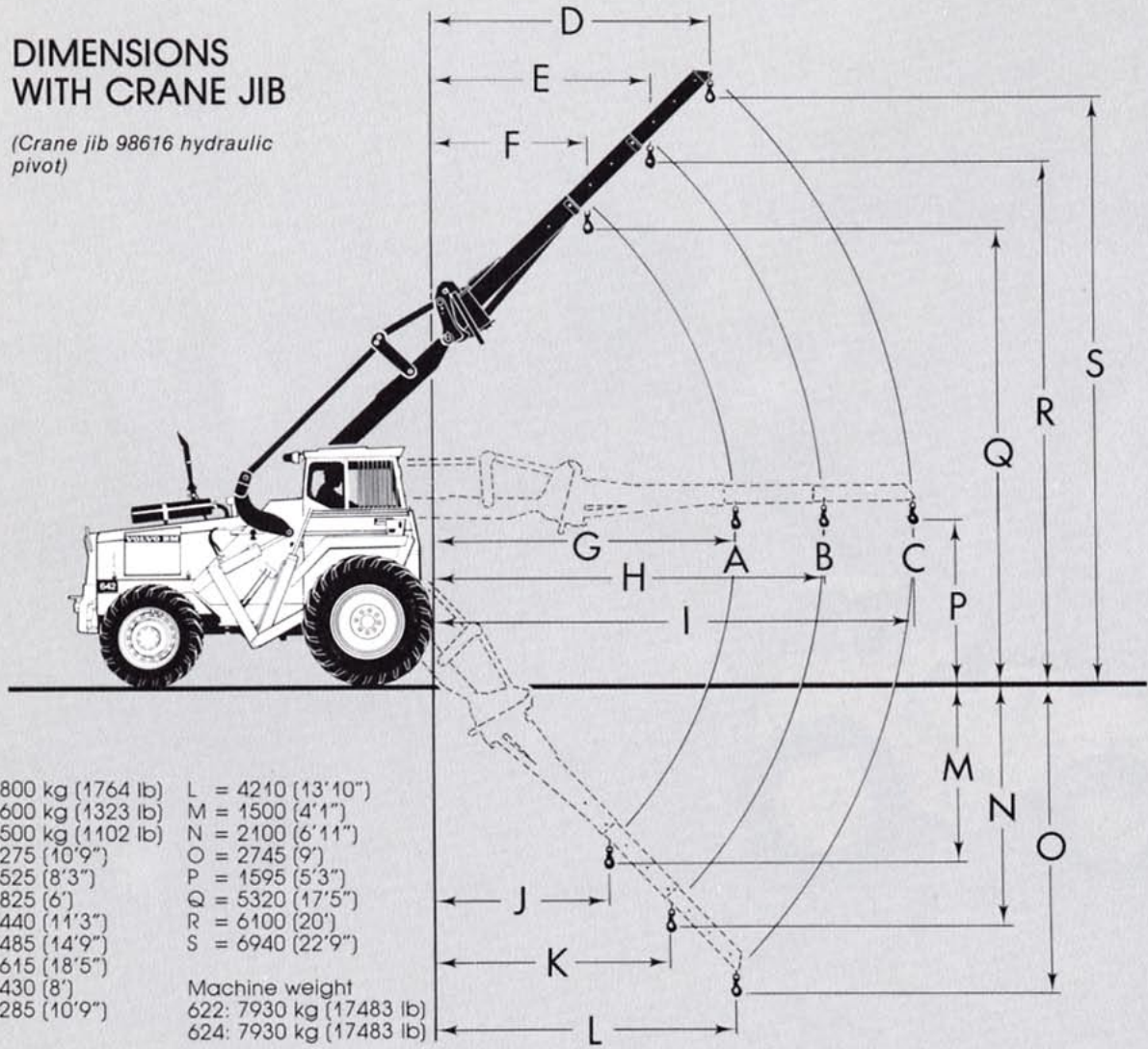

- | | |
|----------------------|-------------------------|
| A = 800 kg (1764 lb) | L = 4210 (13'10") |
| B = 600 kg (1323 lb) | M = 1500 (4'11") |
| C = 500 kg (1102 lb) | N = 2100 (6'11") |
| D = 3275 (10'9") | O = 2745 (9') |
| E = 2525 (8'3") | P = 1595 (5'3") |
| F = 1825 (6') | Q = 5320 (17'5") |
| G = 3440 (11'3") | R = 6100 (20') |
| H = 4485 (14'9") | S = 6940 (22'9") |
| I = 5615 (18'5") | |
| J = 2430 (8') | Machine weight |
| K = 3285 (10'9") | 622: 7930 kg (17483 lb) |
| | 624: 7930 kg (17483 lb) |

DIMENSIONS WITH LOG GRAPPLE

(Log grapple 99323)

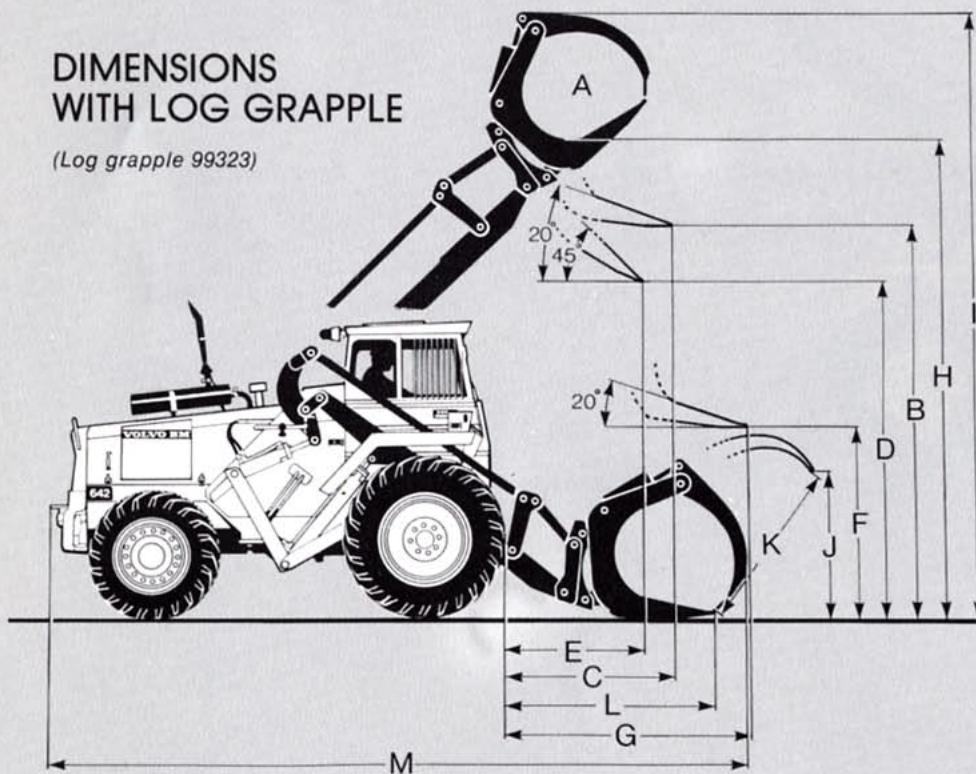

- | |
|------------------------------------|
| A = 0.8 m ² (8.6 sq ft) |
| B = 3500 mm (11'5") |
| C = 1340 mm (4'5") |
| D = 3070 mm (10'1") |
| E = 1100 mm (3'7") |
| F = 1540 mm (5'1") |
| G = 2130 mm (7') |
| H = 4000 mm (13'1") |
| I = 5300 mm (17'4") |
| J = 2000 mm (6'7") |
| K = 2030 mm (6'8") |
| L = 1620 mm (5'4") |
| M = 6075 mm (19'11") |

Working load 2000 kg (4410 lb)

Machine weight
622: 8060 kg (17770 lb)
642: 8060 kg (17770 lb)

DIMENSIONS WITH HIGH-DUMPING BUCKET

(Bucket 98605)

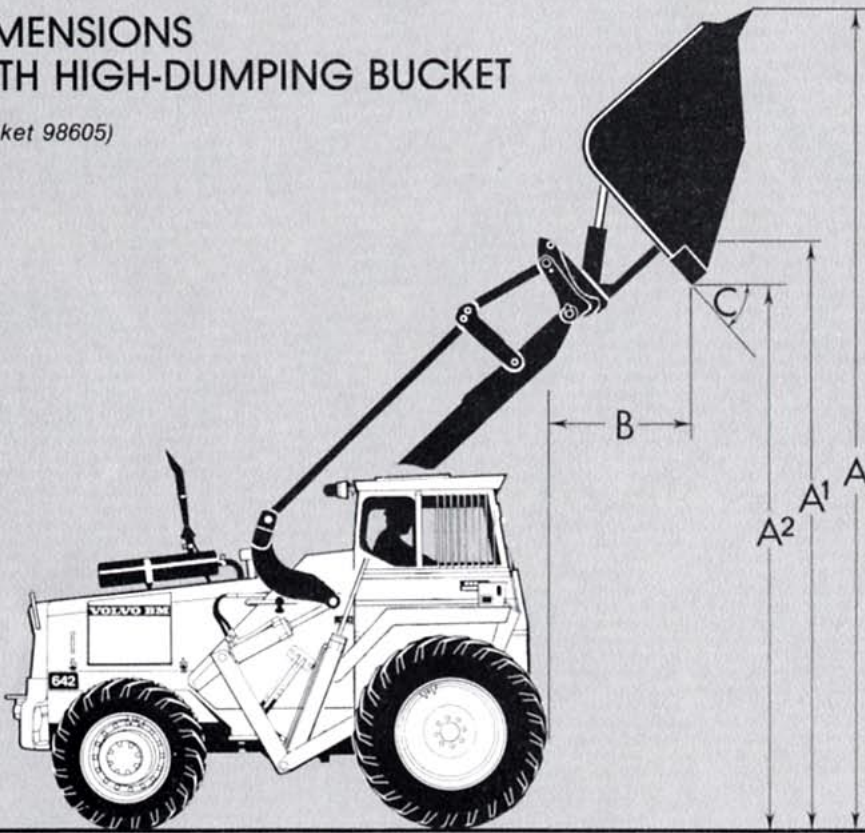

Bucket volume 2.8 m³ (3.7 yd³)
 Tipping load 3160 kg (6967 lb)
 Working load 1580 kg (3483 lb)

A = 5470 mm (17'11")
 A₁ = 4290 mm (14'1")
 A₂ = 3940 mm (12'1")
 B = 1460 mm (4'9")
 C = 43°

Machine weight,
 622: 8285 kg (18265 lb)
 642: 8285 kg (18265 lb)

DIMENSIONS WITH PALLET FORK

(Pallet fork 97789)

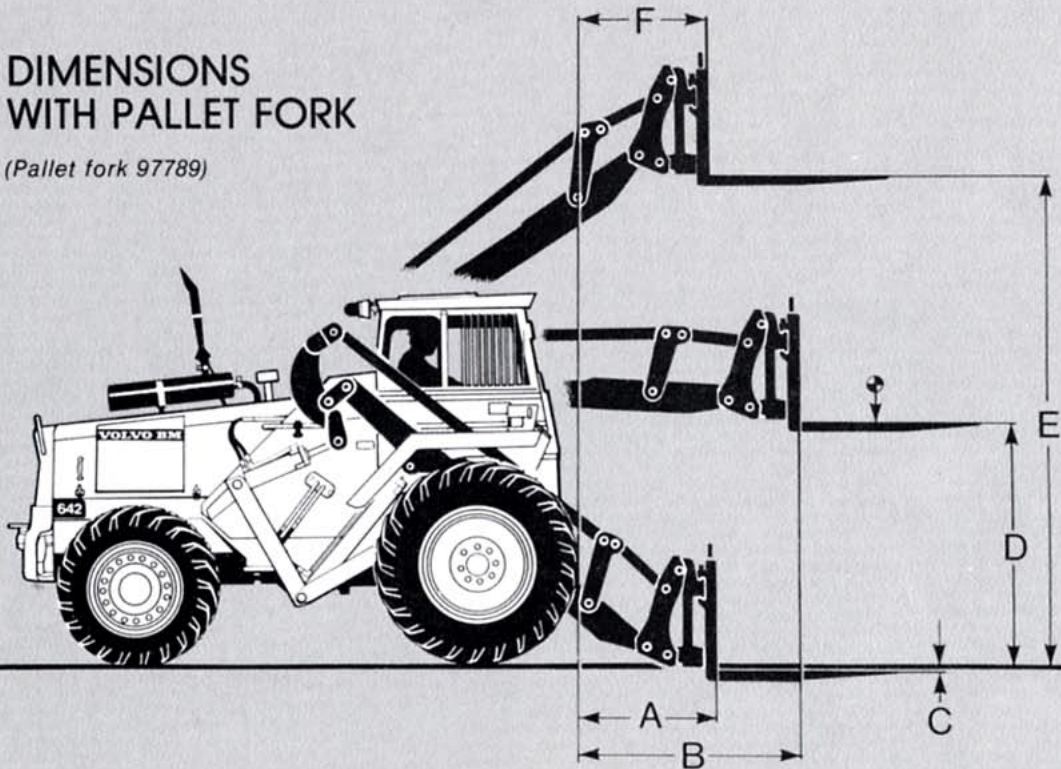

Length, pallet
 fork 97789 1225 mm
 (4')

Width, fork
 carriage 97792 1500 mm
 (4'11")

A = 940 mm (3'1")
 B = 1520 mm (5')
 C = 10 mm (0.5")
 D = 1670 mm (5'6")
 E = 3650 mm (12')
 F = 690 mm (2'3")

Safe working load at center
 of gravity 600 mm elbow

Industrial fork truck
 2500 kg (5513 lb)

Cross-country fork truck
 2000 kg (4410 lb)

Machine weight,
 622: 7900 kg (17420 lb)
 642: 7900 kg (17420 lb)

STANDARD EQUIPMENT



Safety and comfort

- Rear-view mirrors, internal, 2
- Attachments for seat belt
- Utility basket in cab
- Safety cab as per ROPS and ASS
- Cab heater with fresh air intake and defroster
- Instrument panel with symbol markings
- Turn signals
- Horn
- Sun visor
- Lever lock (door-dependent)
- Steering brake
- Safety start
- Hazard flashers
- Tool kit
- Windshield wipers



Engine and electrical system

- Fuel gauge
- Lights: Driving lights, asymmetrical bright/dim/parking lights, rear working lights, brake lights, position lights, cab lighting
- Indicator for air cleaner filter
- Master switch, electrical system
- Pilot lamps for: Rear working lights, battery charging, driving brakes, bright lights, engine oil pressure, parking brake, hydraulic transmission oil pressure
- Temperature gauge, hydraulic transmission
- Hour counter
- Temperature gauge, engine
- Air cleaner with ejector
- Alternator, encapsulated



Power transmission

- Power shift transmission
- Differential lock on front axle
- Torque converter



Hydraulic system

- 3rd hydraulic function
- Attachment bracket with hydraulic lock

OPTIONAL EQUIPMENT

- Front working lights
- Extra fuel filter
- Underbody protection plates
- Tow hitch
- Single-acting hydraulic function
- 6-blade fan
- Spark-arresting muffler
- Hydraulic take-off for trailer tip
- Cab ventilator
- Seat belt
- Control lever, tubing and valve for 4th hydraulic function
- Heated operator's seat
- Control lever (common with 3rd hydraulic function) and tubing and valve for 4th hydraulic function
- Lifting eyes
- Engine block heater, electrical
- Protective grilles for front headlights
- Protective roof for cab ventilator
- Trailer outlet, electrical
- Fenders, front and rear
- Warning beacon incl. collapsible bracket

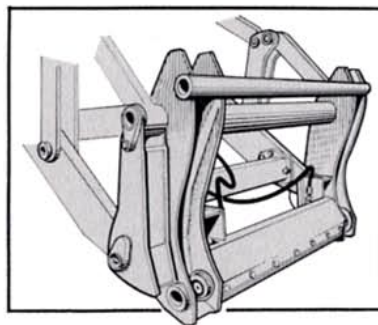

Quick-change coupling

The Volvo BM 622/642 is equipped in the standard version with a hydraulic attachment bracket. This permits efficient utilization of the wide range of attachments available.

Under our policy of continuous product improvement, we reserve the right to change specifications and design without prior notice. The illustrations do not necessarily show the standard version of the machine.

VOLVO BM

VOLVO BM AB ESKILSTUNA SWEDEN

Ref. No. 21 3 669 1556
ENGELSKA

Production group for basic printed matter Volvo BM
Photo: Foto Consult