



Michigan L50B



- **Engine output, gross:**
SAE J1349
71,5 kW
(96 hp)
- **Operating weight:**
7,8 - 9,3 t
(17,200 - 20,510 lb)
- **Buckets:**
1,2 - 3,9 m³
(1.6 - 5.1 yd³)
- **Torque Parallel Linkage** –
The lift-arm system with:
 - unique breakout torque
 - excellent parallel lift-arm action
 - high lift height and long reach
- **Direct-injection, turbocharged diesel engine**
- **Hydrostatic transmission with kick-down function**
- **Enclosed wet circulation-cooled brakes**
- **Care Cab** – the cab with high comfort and safety
- **Stable and easy-to-operate precision steering**
- **Contronic monitoring system (optional equipment)**
- **Pilot-operated hydraulic system**
- **Hydraulic attachment bracket**

MICHIGAN



ENGINE

TD40GA: A 4-cylinder, in-line, direct-injection, turbocharged, 4-stroke diesel engine with dry, replaceable cylinder linings.

Air cleaning: Air cleaning in three stages.

1. Multi-cyclone cleaner with automatic particle ejector
2. Paper filter with indication for clogging
3. Safety filter

Make	VME			
Model	TD 40GA			
Output, gross at	rps	rpm	36,6	2200
SAE J1349	kW	hp	71,5	96
Flywheel output at	rps	rpm	36,6	2200
SAE J1349 Net	kW	hp	68	91
DIN 70020 / 6271	kW	hp	68	91
Max. torque at	rps	rpm	23,3	1400
SAE J1349 Gross	N•m	lbf ft	370	273
SAE J1349 Net	N•m	lbf ft	363	268
DIN 70020 / 6271	N•m	lbf ft	363	268
No. of cylinders			4	
Displacement, total	l	in ³	4	244
Bore	mm	in	100	3.94
Stroke	mm	in	127	5
Compression ratio			16:1	



ELECTRICAL SYSTEM

The electrical system is built up around a distribution box and includes the following functions, among others: kick-down, down-shift protection and central warning.

Central warning:

Central warning lamp for the following functions: engine oil pressure, engine temperature, hydrostatic charge pressure, hydrostatic oil temperature, gearbox oil pressure, brake pressure, parking brake, hydraulic oil level.

The Contronic monitoring system can be selected as optional equipment.

Voltage	V	24		
Batteries	V	2x12		
Battery capacity	Ah	2x105		
Cranking capacity, ea.	A	575		
Reserve capacity, ea.	min.	170		
Alternator rating	W / A	1680 / 60		
Starter motor output	kW	hp	6,0	8.0



SERVICE REFILL CAPACITIES

Crankcase	l	US gal	11	2.9
Fuel tank	l	US gal	170	44.9
Cooling system	l	US gal	22	5.8
Dropbox	l	US gal	7	1.8
Front axle, total	l	US gal	24	6.3
Rear axle, total	l	US gal	24	6.3
Hydraulic system, total	l	US gal	106	28
Hydraulic tank	l	US gal	65	17.2



DRIVETRAIN

Hydrostatic Transmission: The transmission consists of three parts: hydraulic pump, hydraulic motor (both with variable displacement) and a two-stage VME Power Shift gearbox which is actuated via a control lever with a kick-down function.

Axles: VME fully-floating half-shafts with planetary hub reductions. Cast-iron axle housing. Fixed front axle and oscillating rear axle.

Differential: Spiral bevel differentials on front and rear axles.

Hub reduction: VME manufacture with low-friction roller bearings in each wheel.

Tires: Alternative tires are available for different applications.

Running speeds (15.5 R25)

Forward/Reverse		km/h	mph	0 - 15,8	0 - 9.8
Low range		km/h	mph	0 - 5	0 - 3.1
Locked max. displacement		km/h	mph		
High range		km/h	mph	0 - 36,4	0 - 22.6
Locked max. displacement		km/h	mph	0 - 11	0 - 6.8
Front axle, model				AWB 10	
Rear axle, model				AWB 10	
Oscillation	± °			12	
Ground clearance at 12° oscillation	mm	in		365	14.4



BRAKE SYSTEM

The brake system meets the requirements of ISO 3450, SAE J1473 and EG 71/320.

Service brakes: VME fully hydraulic-operated, enclosed wet circulation-cooled disc brakes. Application of brake pedal applies brakes.

Secondary system: Dual-circuit axle-by-axle system. Actuated by service brake pedal. Visual low pressure alarm. Dead engine braking pressure provided by three nitrogen-charged accumulators.

Parking brake: Drum brake on front axle input shaft. Manually operated. A warning lamp lights if the ignition is on when the parking brake is applied. If the gear lever is then placed in forward or reverse, the central warning lamp shines and a buzzer sounds.

Number of discs/wheel			1	
Area per brake lining	cm ²	in ²	1750	271.2
Accumulators				
volume, total	l	US gal	1,5	0.3
Parking brake, friction area, total	cm ²	in ²	406	62.9

DIMENSIONAL DATA MICHIGAN L50B

Tires: 15.5R25*GP2B Goodyear

Where applicable, specifications and dimensions are in accordance with ISO 7131, SAE J732, ISO 7546, SAE J742, ISO 5998, SAE J818.

B	mm	ft in	5220	17'2"
C	mm	ft in	2750	9'0"
D	mm	ft in	380	1'3"
F	mm	ft in	3010	9'11"
G	mm	ft in	2135	7'0"
J	mm	ft in	3460	11'4"
K	mm	ft in	3710	12'2"
O	°		52	
P	°		45	
R	°		44	
R ₁ *	°		49	
S	°		90	
T	mm	ft in	80	0'3"
U	mm	ft in	390	1'3"
X	mm	ft in	1750	5'9"
Y	mm	ft in	2140	7'0"
Z	mm	ft in	3460	11'4"
a ₂	mm	ft in	4850	16'0"
a ₃	mm	ft in	2710	8'11"
a ₄	± °		40	

* Carrying position SAE

Bucket Type

- 1 = Straight bucket without teeth
- 2 = Edge savers

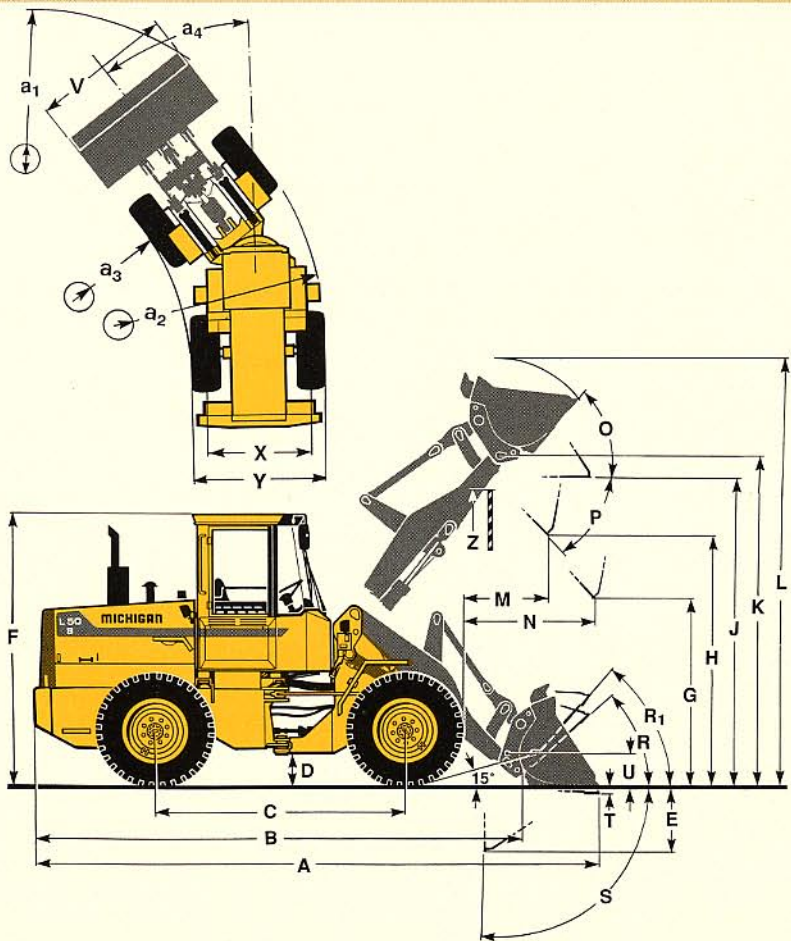

	Standard buckets								Coal Snow	Wood-chips	
	Hook-on		Pin-on		Hook-on		Pin-on		Hook-on	Hook-on	
Bucket type	1/2	1	1/2	1	1/2	1	1/2	1	1	1/2	
Volume, heaped	m ³	1,5	1,4	1,5	1,4	1,3	1,2	1,3	1,2	2,1	3,9
	yd ³	2.0	1.8	2.0	1.8	1.7	1.6	1.7	1.6	2.8	5.1
Struck	m ³	1,1	1,0	1,1	1,0	1,0	0,9	1,0	0,9	1,7	3,2
	yd ³	1.4	1.3	1.4	1.3	1.3	1.2	1.3	1.2	2.2	4.2
Static tipping load, straight	kg	4900	5000	5200	5400	5000	5100	5200	5400	4800	4300
	lb	10,800	11,030	11,470	11,910	11,030	11,250	11,470	11,910	10,580	9,480
at 35° turn	kg	4400	4600	4600	4800	4500	4600	4700	4800	4200	3800
	lb	9,700	10,140	10,140	10,580	9,920	10,140	10,360	10,580	9,260	8,380
at full turn	kg	4200	4400	4500	4700	4300	4400	4500	4700	4100	3700
	lb	9,260	9,700	9,920	10,360	9,480	9,700	9,920	10,360	9,040	8,160
Breakout force	kN	60,6	63,8	64,4	68,1	64,2	67,9	68,5	72,7	49,7	37,1
	lbf	13,620	14,340	14,480	15,310	14,430	15,260	15,400	16,340	11,170	8,340
A	mm	6380	6300	6320	6250	6320	6250	6260	6190	6560	7030
	ft in	20'11"	20'8"	20'9"	20'6"	20'9"	20'6"	20'6"	20'4"	21'6"	23'1"
L	mm	4730	4730	4700	4700	4700	4700	4680	4680	4900	5360
	ft in	15'6"	15'6"	15'5"	15'5"	15'5"	15'5"	15'4"	15'4"	16'1"	17'7"
V	mm	2300	2300	2300	2300	2300	2300	2300	2300	2380	2500
	ft in	7'6"	7'6"	7'6"	7'6"	7'6"	7'6"	7'6"	7'6"	7'10"	8'2"
a ₁ clearance circle	mm	10 800	10 760	10 780	10 730	10 770	10 730	10 740	10 700	10 990	11 390
	ft in	35'5"	35'4"	35'4"	35'2"	35'4"	35'2"	35'3"	35'1"	36'1"	37'4"
E	mm	990	930	930	870	930	870	950	810	1190	1620
	ft in	3'3"	3'1"	3'1"	2'10"	3'1"	2'10"	3'1"	2'8"	3'11"	5'4"
H	mm	2770	2820	2810	2860	2810	2860	2850	2900	2640	2320
	ft in	9'1"	9'3"	9'3"	9'5"	9'3"	9'5"	9'4"	9'6"	8'8"	7'7"
M	mm	1040	1000	990	960	990	960	950	920	1190	1490
	ft in	3'5"	3'3"	3'3"	3'2"	3'3"	3'2"	3'1"	3'0"	3'11"	4'11"
N	mm	1560	1560	1540	1540	1540	1540	1520	1510	1600	1640
	ft in	5'1"	5'1"	5'1"	5'1"	5'1"	5'1"	5'0"	4'11"	5'3"	5'5"
Operating weight	kg	8100	8000	8000	7800	8100	8000	7900	7800	8100	8400
	lb	17,860	17,640	17,640	17,200	17,860	17,640	17,420	17,200	17,860	18,520

MATERIAL HANDLING ARM (92007)

Operating weight	kg	lb	7900	17,420
A	kg	lb	1120	2,470
B	kg	lb	890	1,960
C	kg	lb	720	1,590
D	mm	ft in	2900	9'6"
E	mm	ft in	2250	7'5"
F	mm	ft in	1660	5'5"
G	mm	ft in	3310	10'10"
H	mm	ft in	4340	14'3"
I	mm	ft in	5470	17'11"
J	mm	ft in	1840	6'0"
K	mm	ft in	2570	8'5"
L	mm	ft in	3370	11'1"
M	mm	ft in	1770	5'10"
N	mm	ft in	2500	8'2"
O	mm	ft in	3300	10'10"
P	mm	ft in	1440	4'9"
Q	mm	ft in	5030	16'6"
R	mm	ft in	5880	19'3"
S	mm	ft in	6810	22'4"

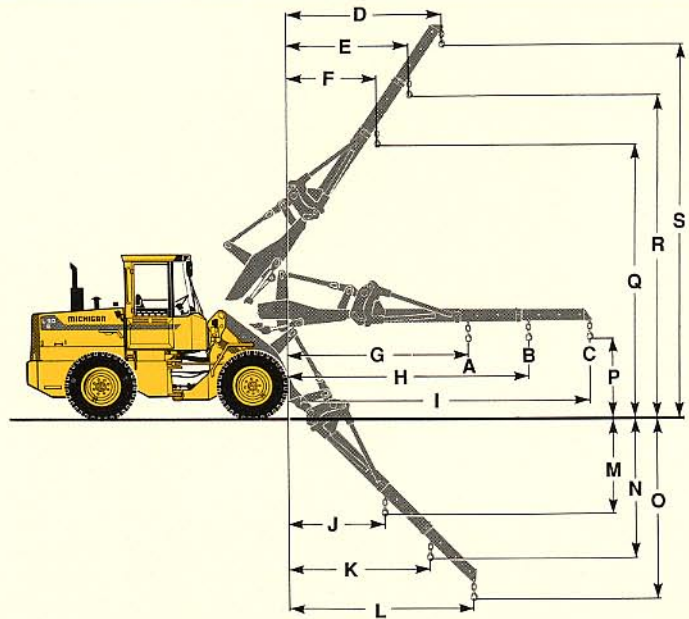

PALLET FORK (Hook-on)

Fork tine order no.	97789			
Length	mm	ft in	1225	4'0"
Fork tine order no.	91177			
Width	mm	ft in	1500	4'11"
Max. permissible load at load center distance	kg	lb	3000	6,620
Operating weight	mm	ft in	600	2'0"
A	kg	lb	8500	18,740
B	mm	ft in	810	2'8"
C	mm	ft in	1570	5'2"
D	mm	ft in	0	0
E	mm	ft in	1740	5'9"
F	mm	ft in	3550	11'8"
	mm	ft in	740	2'5"

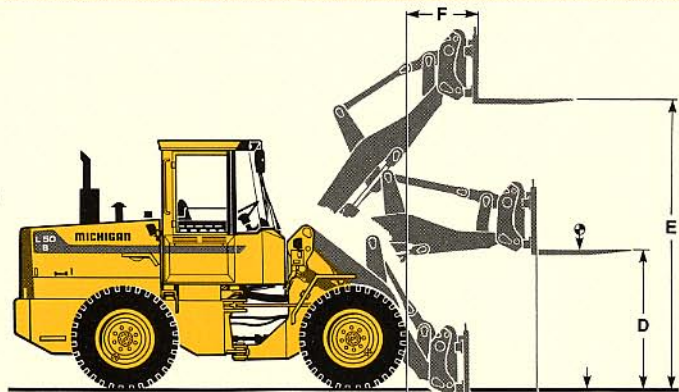

Bucket type	Material Density t/m ³ (lb/yd ³)									
	1.2	1.3	1.4	1.5	1.6	1.7	1.8	1.9	2.0	
m ³ yd ³	2000	2400	2700	3000	3400					
1.2D 1.6D							1.8		1.5	
1.4D 1.8D			1.6	1.3		2.1		1.7		
1.4R 1.8R			1.6	1.3		2.1		1.7		
1.5*R 2.0*R		1.7	1.4			2.3		1.9		

*) Including Edge Savers
R = Bracket-mounted (hook-on)
D = Direct-mounted (pin-on)

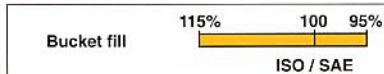

BUCKET SELECTION CHART

The handled volume is often greater than that which is indicated by the bucket's ISO/SAE classification. The table shows optimum bucket choice with regard to the material.

Material densities and bucket fill factors

Material	Earth	Clay	Sand	Gravel	Rock
Bucket fill %	100-115	110-120	100-110	100-110	75-100
Density t/m ³	1.4-1.6	1.4-1.6	1.6-1.9	1.7-1.9	1.5-1.9
Density lb/yd ³	2400-2700	2400-2700	2700-3200	2900-3200	2500-3200

CHANGE IN DIMENSIONAL DATA

Tires	15.5-25, L2		17.5 R 25*, L2		17.5-25, L2		Counterweight 1		Counterweight 2		
Width over wheels	mm	in	+10	+0.4	+90	+3.5	+70	+2.8	-	-	
Ground clearance	mm	in	-30	-1.2	+20	+0.8	+10	+0.4	-	-	
Tipping load at full turn	kg	lb	-100	-220	+200	+440	0	+400	+880	+500	+1100
Operating weight	kg	lb	-130	-290	+190	+420	0	+170	+375	+235	+520



STEERING SYSTEM

Load-sensing hydrostatic articulated steering.

Pump: Axle-flow piston pump with variable flow.

System supply: The steering system has prioritized feed from the machine's load-sensing axial-flow piston pump.

Cylinders: Two double-acting cylinders with chromium-plated piston rods.

Steering cylinders			2	
Bore	mm	in	63	2.48
Piston rod diameter	mm	in	40	1.57
Stroke	mm	in	320	12.59
Relief pressure	MPa	psi	21	3045
Articulation	±°		40	



CAB

Tested and approved in accordance with the following standards: ROPS ISO/CD 3471, SAE J1040, FOPS ISO 3449, SAE J231, and complies with the requirements for "Overhead guards for fork lift trucks" in ISO 6055 and the requirements for Operator Restraint Systems in SAE J386.

Safety and comfort: The *Care Cab* has a convenient boarding ladder and a wide door opening. It is lined with sound-absorbent materials and mounted on four sound-and vibration-damping rubber isolator pads.

Large glazed areas, good all-round visibility. The windshield is curved and made of laminated green-tinted glass.

All important information is readily visible in front of the operator. Cab display for *Contronic* monitoring system available as optional equipment.

Heater and defroster: 4-speed cab-pressurizing fan, plus defroster for all windows. Heating element with filtered fresh air intake.

Operator's seat: Spring-suspended, adjustable operator's seat with seat belt. The seat is hung on a bracket on the rear wall. The force from the seat belt is absorbed by the seat rails.

Emergency exits			3	
Sound level in cab (ISO 6396)				
max.	dB(A)		75	
Ventilation	m ³ /min	cfm	10	353
Heating capacity	kW	Btu/h	11	37500
Operator's seat		ISRI		6000/575
Air conditioning (optional)	kW	Btu/h	7	24000



HYDRAULIC SYSTEM

Load-sensing pressure-compensated hydraulic system with a single axial-flow piston pump for the working hydraulics, pilot hydraulics, steering system, brake system and other hydraulic functions.

Pump: The load-sensing axial-flow piston pump adjusts itself to the oil need in the relevant function via indication through a load-sensing line. The flow is routed to the system via a pilot-controlled selector valve. The steering function always has priority.

Valve: Double-acting 2-spool valve. The actuator valve is controlled by a 2-spool pilot valve.

Lift circuit: The valve has four positions: raise, neutral, lower and float. Inductive/magnetic automatic boom kick-out can be switched on and off. Adjustable to any position between maximum reach and full lift height.

Tilt circuit: The valve has three positions: rollback, neutral and dump. Inductive/magnetic automatic bucket positioner, which can be switched on and off, sets the desired bucket angle (normally return-to-dig angle).

Cylinders: Double-acting.

Filter: Full-flow filtration through 10 micron filter cartridge.

Loader unit: *Torque Parallel Linkage* – with high breakout torque throughout the working range. Good parallel lift-arm action throughout the lifting range, with both level and fully angled-up bucket. The lift cylinders are installed in line with the lift arms. The tilt cylinder is installed between the lift arms.

Axial-flow piston pump				
Relief pressure	MPa	psi	26,0	3771
Flow	l/min	US gpm	120	31.7
at	MPa	psi	10	1450
and engine speed	rps	rpm	36,7	2200
Pilot system				
Relief pressure	MPa	psi	3,5	508
Lift cylinders			2	
Bore	mm	in	90	3.5
Piston rod diameter	mm	in	60	2.3
Stroke	mm	in	669	26.3
Tilt cylinder			1	
Bore	mm	in	125	4.9
Piston rod diameter	mm	in	70	2.8
Stroke	mm	in	434	17.1
Raise time *	s		4.4	
Dump time	s		1.1	
Lower time (empty)	s		3.3	
Total cycle time	s		8.8	

* with load as per ISO 5998 and SAE J818.

STANDARD EQUIPMENT

<p>Safety & Comfort Cab: ROPS (SAE J1040CC) (ISO 3471), FOPS (SAE J231) (ISO 3449). Acoustical Lining Ashtray Cigarette Lighter Door, Lockable (left side access) Heater/Defroster/Pressurizer 37,500 Btu/h (11 kW) with Four-Speed Blower Fan Filtered Air Floor Mat Interior Light Interior Rearview Mirror Mirrors Rearview (2), Exterior Openable Window, right-hand side Safety Glass, Tinted Seat Belt (SAE J386) Seat, Ergonomically Designed, Suspension Adjustable Steering Wheel, Adjustable Tilt Storage Compartment Sun Visor Windshield Washer, Front & Rear Windshield Wiper, Front & Rear Cab Access Steps & Handrails Fenders, Front & Rear with Anti-Skid Tape</p> <p>Engine & Electrical System Air Cleaner, Dry Type, Dual</p>	<p>Element, Exhaust Aspirated Precleaner Coolant Filter Coolant Level, Sight Gauge Engine Intake Manifold Preheater Exhaust Rain Cap (built-in) Muffler, Spark Arresting Electrical System 24V Pre-wired for Optional Accessories Alternator, 24V, 60 AMP Battery Disconnect Switch Fuel Gauge Hourmeter Instrument Panel with Symbols Lights: Driving (2-Front), Halogen with High/Low Beam Parking Lights Stop/Tail Combination (2-Rear) Turn Signals with Hazard Warning Switch Working Lights, Halogen (2-Front, 2-Rear) Instrument Lighting Neutral Start Feature Test Function for Warning & Monitoring Lights Warning & Monitoring Lights: Engine Oil Pressure Engine Coolant Temperature Air Cleaner Restriction Alternator Malfunction Working Lights High Beam Driving Lights Direction Indicator, Hazard</p>	<p>Warning Flasher Hydrostatic Charge Oil Pressure Hydrostatic Oil Temperature Hydrostatic Oil Filter Gearbox Oil Pressure Brake System Pressure Parking Brake Applied Hydraulic Oil Level</p> <p>Central Warning (with Buzzer) Engine Oil Pressure Engine Coolant Temperature Hydrostatic Charge Oil Pressure Hydrostatic Oil Temperature Gearbox Oil Pressure Brake System Pressure Parking Brake Applied and Transmission in Forward or Reverse (buzzer) Hydraulic Oil Level Horn, Electric Reverse Alarm (SAE J994)</p> <p>Drivetrain Hydrostatic Transmission Hydraulic Oil Cooler Single-Lever Shift Control Power-Shift Gearbox, 2-Stage Differentials, Front & Rear, Conventional Tires 15.5-25(12PR) L2 General</p> <p>Brake System Wet, Circulation-Cooled Disc</p>	<p>Brakes, 4-Wheel, Dual Circuit Brake System, Secondary Parking Brake Alarm</p> <p>Hydraulic System Main Valve, 2-Spool, Pilot Operated Pilot Valve, 2-Spool Axial Piston Pump Attachment Bracket with Separate Locking System Bucket Lever Detent Bucket Leveler, Automatic with Position Indicator Boom Lever Detents Boom Kickout, Automatic, Adjustable Hydraulic Control Lever Safety Latch Boom Lowering System Hydraulic Pressure Test Ports, Quick Connect Hydraulic Fluid Level, Sight Gauge</p> <p>External Equipment Drawbar with Pin Isolator Mounts: Cab, Engine, Gearbox Lifting Lugs Side Panels, Engine Hood Steering Frame Lock Vandalism Lock, Provision for: Batteries Engine Oil</p>
--	---	--	---

OPTIONAL EQUIPMENT

<p>Service & Maintenance Equipment Tool Box Tool Kit</p> <p>Engine Equipment Low Emission Version Cold Starting Aid, Engine Coolant Preheater (120V/750W or 240V/750W)</p> <p>Electrical Equipment Contronic Monitoring System, ECU Working Lights, Front, extra Working Lights, Rear, extra Rotating Beacon, Amber with Collapsible Mount Intermittent Wiper, Front (incl. in Contronic Monitoring System)</p>	<p>Transmission Equipment Forward & Reverse Switch Front Axle with 100% Diff. Lock</p> <p>Cab Equipment Installation Kit for Radio Instructor's Seat Hand Throttle Sliding Ventilation Window, Door Speedometer Air Suspended Operator's Seat Heated Operator's Seat Retractable Seat Belt Contronic Display Air Conditioner 24,000 Btu/h (7 kW) Dual Service Brake Pedals Engine Coolant Temperature Gauge, only with ECU Hydrostatic Transmission Oil Temperature Gauge, only with ECU</p>	<p>Hydraulic Equipment Hydraulic Control for 3rd Function Includes 3rd spool for both main and pilot valve, and plumbing. Hydraulic Control for 4th Function Hydraulic Single Acting Lifting Function Boom Suspension System</p> <p>External Equipment Fenders, extended Counterweight I Counterweight II</p> <p>Other Equipment Comfort Drive Control (CDC) Slow Moving Vehicle Emblem</p>	<p>Tires 15.5-25/12 L2 15.5 R 25* 17.5-25/12 L2 17.5 R 25*</p> <p>Attachments Buckets Fork Equipment Material Handling Arm Timber Grapples Diagonal Snow Blade Broom Asphalt Cutter Attachment Rib Kit (Adapt your existing equipment to the L50B) Cutting Edge, 3-pc. Reversible Bolt-On Bucket Teeth, Bolt-On (8)</p>
--	---	--	---

Under our policy of continuous product improvement, we reserve the right to change specifications and design without prior notice. The illustrations do not necessarily show the standard version of the machine.

VME Sales North America

One West Pack Square
BB&T Building
Asheville, NC 28801

Ref. No. 22 1 669 1981
DATE 2/93
Printed in U.S.A.