



# Michigan L320



- *Engine output gross:  
SAE J1349 337 kW  
(452 hp)*
- *Operating weight:  
48,8 t  
(107,768 lb)*
- *Buckets:  
5,7 - 11,5 m<sup>3</sup>  
(7.5 - 15.0 yd<sup>3</sup>)*
- *Standard and Long Booms*
- *Direct-injected, turbocharged,  
aftercooled, Cummins diesel*
- *Powershift transmission with  
single lever control*
- *Enclosed multi-disc, oil cooled,  
wet disc brakes*
- *Limited slip differentials, front  
and rear*
- *Full hydraulic, flow amplified,  
steering for low effort and  
ease of control*
- *Deluxe cab with great comfort,  
safety, and high visibility*
- *Monitoring system for brakes  
and other functions*
- *Pilot-operated, seat-mounted,  
fingertip hydraulic controls*

**MICHIGAN**



## ENGINE

Direct-injected, turbocharged and aftercooled 6 cylinder, in-line, 4-cycle diesel.

Make			Cummins	
Model			KTA 19C	
Max. rating* at	rps	rpm	35	2100
SAE J1349 (ISO 1585)	kW	hp	337	452
Flywheel rating** at	rps	rpm	35	2100
SAE J1349 (ISO 1585)	kW	hp	311	417
DIN 70020 / 6271	kW	hp	311	417
Max. torque at	rps	rpm	25	1500
SAE J1349 (ISO 1585)	N•m	lbf ft	2165	1597
DIN 70020 / 6271	N•m	lbf ft	2165	1597
No. of cylinders			6	
Displacement, total	l	in <sup>3</sup>	18,8	1150
Bore	mm	in	158,8	6.25
Stroke	mm	in	158,8	6.25

### Air Cleaner

1. Cyclone precleaner with automatic dust ejector.
2. Paper filter with restriction indicator.
3. Replaceable safety filter.

\***Max. rating** - Rating of engine equipped only with components essential for engine function, such as injection pump, oil pump and water pump.

\*\***Flywheel rating** - Net rating measured with fan, intake and exhaust system, cooling system, and alternator mounted.



## ELECTRICAL SYSTEM

The electrical system is well protected by circuit breakers and prewired for optional equipment.

Voltage	V	24
Alternator	A	100
Batteries (12 volt)		4
Battery capacity, total	CCA	1250
Cranking capacity, each	CCA	625



## SERVICE REFILL CAPACITIES

Crankcase	l	US gal	51,1	13.5
Fuel tank (total)	l	US gal	803	212.0
Fuel tank (usable)	l	US gal	791	209.0
Cooling system	l	US gal	132,5	35.0
Transmission (total)	l	US gal	68,1	18.0
Wheel hubs, each	l	US gal	9,8	2.6
Differentials, each	l	US gal	68,1	18.0
Midmount bearing	l	US gal	5,3	1.4
Hydraulic system (total)	l	US gal	606	160.0
Hydraulic tank	l	US gal	345	91.0



## DRIVETRAIN

**Torque converter:** Clark, high efficiency, single stage, single phase.

**Transmission:** Clark, countershaft-type powershift transmission with directional clutch modulation.

**Axles:** Clark, full-floating axle shafts with planetary-type hub reductions. Single piece cast axle housings. Fixed front axle and oscillating rear axle.

**Differentials:** Clark, limited slip differentials in front and rear axles.

**Hub reduction:** Clark, planetary drive with low-friction roller bearings in each wheel hub.

**Tires:** Tubeless with nylon cord body. Alternative tires available for specific applications.

Torque converter make, model			Clark, C 8612-76
Torque multiplication			2.536:1
Transmission make, model			Clark, 6421-11
Running speeds			
1, forward/reverse	km/h	mph	7,1 4.4
2, forward/reverse	km/h	mph	12,4 7.7
3, forward/reverse	km/h	mph	20,9 13.0
4, forward/reverse	km/h	mph	35,4 22.1
Measurement with tires			35/65-33 (30PR) L-4
Front axle make, model			Clark, 21D5073
Rear axle make, model			Clark, 21D5073
Rear axle oscillation, total			24°
	mm	in	559 22



## BRAKE SYSTEM

The brake system meets requirements according to SAE J1152, ISO 3450.

**Service brakes:** Full hydraulic system with outboard mounted, oil-cooled, wet disc brakes at each wheel.

Both pedals apply brakes and declutch transmission into neutral. A separate dash-mounted switch allows the operator to deactivate this declutch feature.

**Secondary:** Dual circuit axle-by-axle system. Actuated by service brake pedals. Audible and visual low pressure alarm. Dead engine braking capability provided by two nitrogen-charged accumulators.

**Parking brake:** Dry disc type mounted on front axle input shaft. Spring applied, hydraulically released; actuated by dash-mounted switch.

Transmission interlock applies service brakes if shifted into forward or reverse to prevent moving machine when parking brake is applied.

**Pump:** Piston pump, pressure compensated.

**Filtration:** Full flow, 10 micron filter.

Pressure setting	MPa	psi	20,7	3000
Service brake, disc dia.	mm	in	453	17.82
Parking brake, disc dia.	mm	in	457	18
thickness	mm	in	12,7	0.5





## STEERING SYSTEM

Steering system meets requirements according to SAE J1511, ISO 5010.

**Articulated frame:** Full hydraulic steering system with speed sensor hydraulics.

**Pump:** One gear-type, mounted on the torque converter.

**Supply system:** The system is served by a steer pump and a separate switch pump which is speed and pressure sensitive and feeds either the steering system or the main hydraulic system.

**Cylinders:** Two double-acting cushioned cylinders.

Steering cylinders, no.			2	
Bore	mm	in	127	5.0
Stroke	mm	in	497	19.56
Relief pressure	MPa	psi	19,7	2850
Steer pump output	l/min	US gal/min	250	66
at pressure	MPa	psi	6,9	1000
and engine speed	rps	rpm	35	2100
Secondary pump output	l/min	US gal/min	148	39
at pressure	MPa	psi	6,9	1000
and engine speed	rps	rpm	25	1500
Articulation			35°	



## CAB

**Cab:** (non-ROPS) with two lockable doors. Sound-insulating lining. Sliding self-locking windows. Tinted safety glass in all windows.

**Canopy:** ROPS/FOPS (SAE J1040, ISO 3471).

**Heater/Defroster/Air Conditioner:** (SAE J231, ISO 3449). Provides filtered (10 micron) fresh air and has a three-speed fan and a defroster for the front and side windows.

Heater	kW	Btu/h	12,3	42,000
Air Conditioner	kW	Btu/h	6,3	21,000

**Operator's seat:** Fully adjustable air suspension seat with seat belt (SAE J386).

Sound level in closed cab, max	ISO 6394	dB(A)	77
	SAE J919	dB(A)	82.3
	EEC 86/662	dB(A)	79.6



## BUCKETS (Standard Boom)

A - Straight edge rock	m <sup>3</sup>	yd <sup>3</sup>	6,1	8.0
A - Spade-nose rock	m <sup>3</sup>	yd <sup>3</sup>	6,1	8.0
B - Material handling	m <sup>3</sup>	yd <sup>3</sup>	6,9	9.0

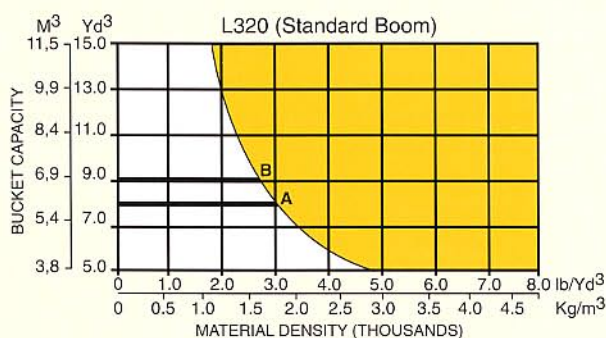

## HYDRAULIC SYSTEM

Closed and pressurized pressure-sensing system with a sturdy plate-steel tank. Hydraulic oil is fully filtered and cooled. An access hole is provided in the tank for easy cleaning. An in-tank magnet provides extra protection.

**Pump:** Three gear-type pumps, mounted on torque converter.

**Supply system:** The system is served by two main pumps and a speed and pressure sensitive switch pump that feeds either the main hydraulic system or the steering system.

**Valve:** Split-spool valve with built-in pressure relief valve. Actuated by a pilot valve, it is mounted on front frame for easy access.

**Lift function:** The valve has four positions: raise, hold, lower and float. An automatic kickout detent is adjustable for any position between maximum reach and full lift height.

**Tilt function:** The valve has three positions: rollback, hold and dump. Automatic bucket positioner is adjustable to any desired loading angle.

**Cylinders:** Double-acting.

**Filters:** Full-flow 10 micron return filter (with two elements), located in hydraulic oil tank.

Relief pressure	MPa	psi	20	2900
Main pump output	l/min	US gal/min	734	194
at pressure	MPa	psi	6,9	1000
and engine speed	rps	rpm	35	2100
Lift cylinders, no.			2	
Bore	mm	in	229	9.0
Stroke	mm	in	1168	46.0
Tilt cylinders, no.			2	
Bore	mm	in	191	7.5
Stroke	mm	in	808	31.8
Raising time (loaded)	s		9.0	
Dumping time (loaded)	s		2.1	
Lowering time (empty)	s		5.4	
Total cycle time	s		16.5	

## BUCKETS (Long Boom)

A - Straight edge rock	m <sup>3</sup>	yd <sup>3</sup>	5,7	7.5
A - Spade-nose rock	m <sup>3</sup>	yd <sup>3</sup>	5,7	7.5
C - Light materials	m <sup>3</sup>	yd <sup>3</sup>	11,5	15.0

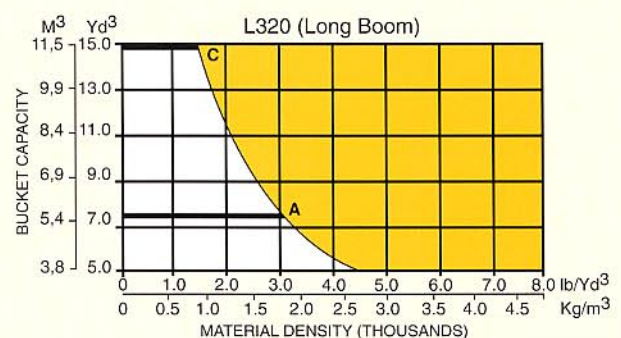



## OPERATIONAL DATA - MICHIGAN L320 (Standard Boom)

**Tires: 35/65-33 (30PR) L-4**

<b>BUCKET TYPE</b>		Straight Edge Rock	S.E. Rock w/Teeth*	S.E. Rock w/BOE	S.E. Rock w/Teeth & Wear Caps*	Spade Nose Rock	S.N. Rock w/Teeth*	S.N. Rock w/BOE	S.N. Rock w/Teeth & Wear Caps*	Material Handling	Material Handling w/BOE
Volume, heaped	m <sup>3</sup>	6,1	6,1	6,4	6,5	6,1	6,1	6,4	6,3	6,9	7,2
	yd <sup>3</sup>	<b>8.0</b>	<b>8.0</b>	<b>8.4</b>	<b>8.5</b>	<b>8.0</b>	<b>8.0</b>	<b>8.4</b>	<b>8.3</b>	<b>9.0</b>	<b>9.4</b>
struck	m <sup>3</sup>	5,1	5,1	5,3	5,5	5,3	5,3	5,5	5,4	6,0	6,3
	yd <sup>3</sup>	<b>6.6</b>	<b>6.6</b>	<b>6.9</b>	<b>7.2</b>	<b>6.9</b>	<b>6.9</b>	<b>7.2</b>	<b>7.1</b>	<b>7.9</b>	<b>8.2</b>
Bucket weight	kg	4 096	4 359	4 560	4 586	4 581	4 581	5 052	5 071	4 173	4 638
	lb	<b>9,030</b>	<b>9,610</b>	<b>10,054</b>	<b>10,110</b>	<b>10,100</b>	<b>10,680</b>	<b>11,138</b>	<b>11,180</b>	<b>9,200</b>	<b>10,224</b>
Static tipping load, straight	kg	35 249	34 919	34 511	34 634	34 617	34 287	33 981	34 002	35 087	34 326
	lb	<b>77,709</b>	<b>76,981</b>	<b>76,083</b>	<b>76,354</b>	<b>76,316</b>	<b>75,588</b>	<b>74,915</b>	<b>74,961</b>	<b>77,353</b>	<b>75,674</b>
full turn	kg	31 380	31 095	30 659	30 842	30 762	30 473	29 008	30 224	31 226	29 355
	lb	<b>69,179</b>	<b>68,551</b>	<b>67,591</b>	<b>67,993</b>	<b>67,817</b>	<b>67,180</b>	<b>63,950</b>	<b>66,631</b>	<b>68,841</b>	<b>64,716</b>
Breakout force	kN	452,1	452,1	443,2	439,7	336,0	336,0	327,6	327,4	413,5	405,4
	lbf	<b>101,600</b>	<b>101,600</b>	<b>99,607</b>	<b>98,820</b>	<b>86,737</b>	<b>86,737</b>	<b>84,566</b>	<b>84,530</b>	<b>92,960</b>	<b>90,941</b>
A	mm	10 452	10 484	10 518	10 484	10 706	11 043	10 770	11 043	10 592	10 658
	ft in	<b>34'3.5"</b>	<b>34'4.75"</b>	<b>34'6.1"</b>	<b>34'4.75"</b>	<b>35'1.5"</b>	<b>36'2.75"</b>	<b>35'4"</b>	<b>36'2.75"</b>	<b>34'9"</b>	<b>34'11.6"</b>
H	mm	3 785	3 546	3 739	3 546	3 632	3 393	3 586	3 393	3 696	3 630
	ft in	<b>12'5"</b>	<b>11'7.6"</b>	<b>12'3.2"</b>	<b>11'7.6"</b>	<b>11'11"</b>	<b>11'1.6"</b>	<b>11'9.2"</b>	<b>11'1.6"</b>	<b>12'1.5"</b>	<b>11'10.9"</b>
K	mm	5 055	5 055	5 055	5 055	5 055	5 055	5 055	5 055	5 055	5 055
	ft in	<b>16'7"</b>	<b>16'7"</b>	<b>16'7"</b>	<b>16'7"</b>	<b>16'7"</b>	<b>16'7"</b>	<b>16'7"</b>	<b>16'7"</b>	<b>16'7"</b>	<b>16'7"</b>
L	mm	7 137	7 137	7 137	7 137	7 137	7 137	7 137	7 137	6 909	6 909
	ft in	<b>23'5"</b>	<b>23'5"</b>	<b>23'5"</b>	<b>23'5"</b>	<b>23'5"</b>	<b>23'5"</b>	<b>23'5"</b>	<b>23'5"</b>	<b>22'8"</b>	<b>22'8"</b>
M	mm	1 689	1 928	1 734	1 928	1 880	2 118	1 925	2 118	1 778	1 830
	ft in	<b>5'6.5"</b>	<b>6'3.9"</b>	<b>5'8.3"</b>	<b>6'3.9"</b>	<b>6'2"</b>	<b>6'11.4"</b>	<b>6'3.8"</b>	<b>6'11.4"</b>	<b>5'10"</b>	<b>6'0.6"</b>
N	mm	2 476	2 715	2 543	2 715	2 616	2 855	2 687	2 855	2 540	2 606
	ft in	<b>8'1.5"</b>	<b>8'10.9"</b>	<b>8'4.1"</b>	<b>8'10.9"</b>	<b>8'7"</b>	<b>9'4.4"</b>	<b>8'9.8"</b>	<b>9'4.4"</b>	<b>8'4"</b>	<b>8'6.6"</b>
T	mm	81	147	119	147	81	147	119	147	91	130
	ft in	<b>3.2"</b>	<b>5.8"</b>	<b>4.7"</b>	<b>5.8"</b>	<b>3.2"</b>	<b>5.8"</b>	<b>4.7"</b>	<b>5.8"</b>	<b>3.6"</b>	<b>5.1"</b>
V	mm	3 962	3 962	3 962	3 962	3 962	3 962	3 962	3 962	3 962	3 962
	ft in	<b>13'0"</b>	<b>13'0"</b>	<b>13'0"</b>	<b>13'0"</b>	<b>13'0"</b>	<b>13'0"</b>	<b>13'0"</b>	<b>13'0"</b>	<b>13'0"</b>	<b>13'0"</b>
a <sub>1</sub> Clearance circle (over bucket in carry position)	mm	18 009	18 009	18 009	18 009	18 034	18 034	18 034	18 034	18 009	18 009
	ft in	<b>59'1"</b>	<b>59'1"</b>	<b>59'1"</b>	<b>59'1"</b>	<b>59'2"</b>	<b>59'2"</b>	<b>59'2"</b>	<b>59'2"</b>	<b>59'1"</b>	<b>59'1"</b>
Operating weight	kg	46 167	46 430	46 632	46 657	46 653	46 916	47 120	47 143	46 372	46 836
	lb	<b>101,780</b>	<b>102,360</b>	<b>102,804</b>	<b>102,860</b>	<b>102,850</b>	<b>103,430</b>	<b>103,880</b>	<b>103,930</b>	<b>102,230</b>	<b>103,254</b>

\*#47 ARL Teeth. Other teeth may affect dimensions differently. Dimensions measured to tips of teeth.

Bolt-on-Edge (BOE) adds 0.3m<sup>3</sup> (0.4yd<sup>3</sup>) to heaped capacity.

Maximum Grading Angle = 46°

## OPERATIONAL DATA & DIMENSIONS - MICHIGAN L320 (Standard Boom)

### Tires: 35/65-33 (30PR) L-4

Wherever applicable, specifications are in accordance with SAE Standards J732 and J742. Changes from the standard configuration may change machine dimensions and operating data. Operating weight is approximate and includes the bucket given in the table, ROPS canopy, cab, all standard equipment, and counterweight #1.

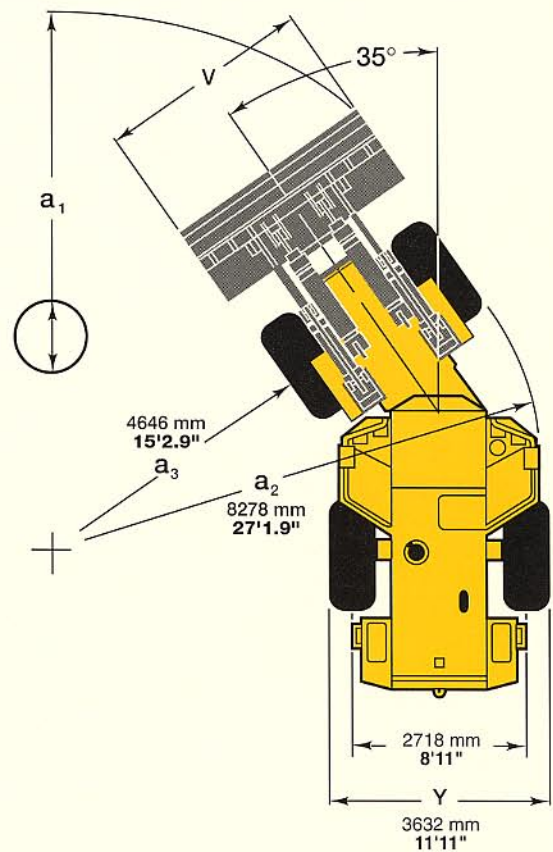
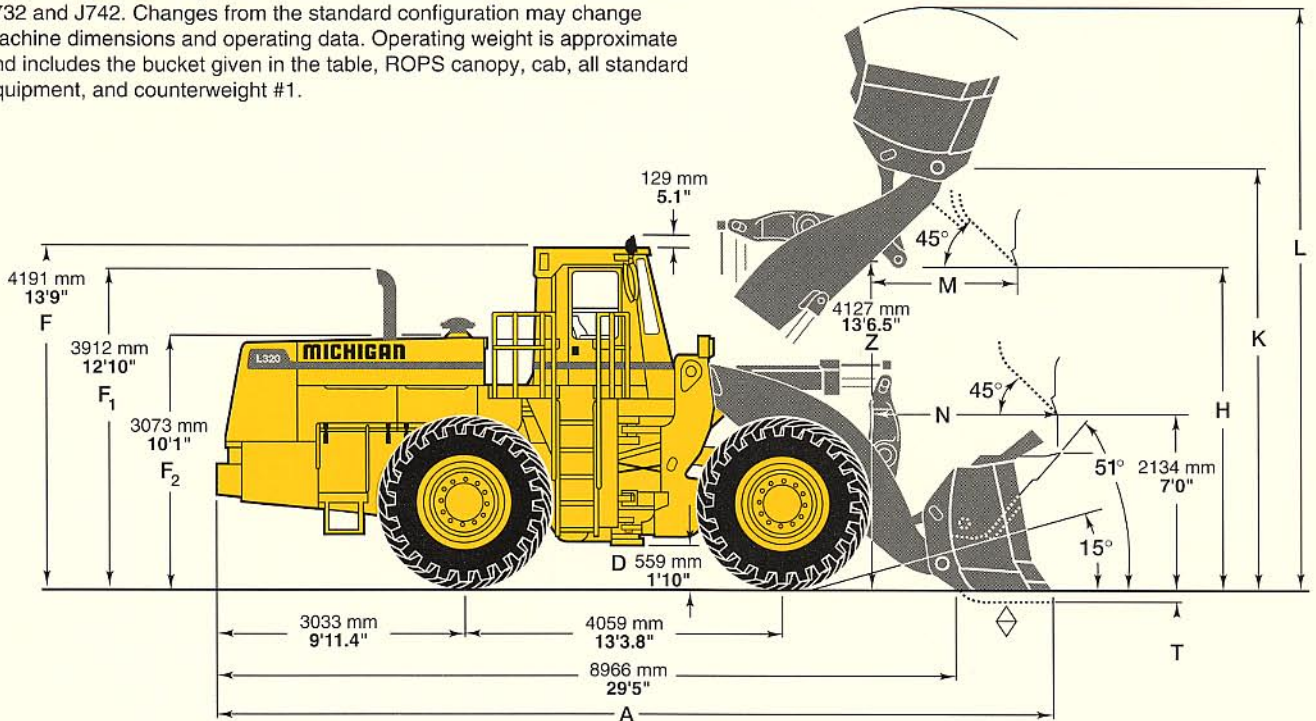



## OPERATIONAL DATA - MICHIGAN L320 (Standard Boom)

### Tires: 35/65-33 (30PR) L-4

SUPPLEMENTAL OPERATING DATA			Change in operating weight		Change in static tipping load straight		Change in static tipping load at full turn	
			kg	lb	kg	lb	kg	lb
Air conditioner (removal)	kg	lb	-82	-180	-139	-306	-122	-270
Bolt-on cutting edge	kg	lb	+468	+1031	-687	-1514	-680	-1499
Bucket points & adapters								
47 ARL, 1 1/2 leg	kg	lb	+263	+580	-330	-728	-289	-637
57 ARL, 1 1/2 leg	kg	lb	+422	+930	-529	-1167	-463	-1021
cutting edge wear caps	kg	lb	+227	+500	-286	-627	-249	-549
Cab (removal)	kg	lb	-386	-850	-276	-609	-275	-606
Counterweight #1 (removal)	kg	lb	-1161	-2560	-2597	-5726	-2286	-5040
Counterweight #2 *	kg	lb	+874	+1926	+1975	+4353	+1765	+3892
Fenders, front	kg	lb	+159	+350	+45	+100	+45	+100
Fenders, rear with steps	kg	lb	+454	+1000	+735	+1620	+653	+1440
ROPS canopy (removal)	kg	lb	-771	-1700	-552	-1218	-550	-1212
Secondary steering	kg	lb	+45	+100	+64	+142	+58	+128
3rd hydraulic control	kg	lb	+52	+115	+42	+93	+41	+90
Optional tires:								
35/65-33 (24PR) L-4	kg	lb	-640	-1412	-449	-990	-408	-900
35/65-33 (24PR) L-5	kg	lb	+337	+744	+236	+520	+218	+480
35/65-33 (30PR) L-5	kg	lb	+662	+1460	+467	+1030	+422	+930
35/65R33 XRDNAT★	kg	lb	-802	-1769	-562	-1240	-512	-1130
35/65R33 XRD1AT★	kg	lb	-628	-1384	-440	-970	-399	-880
35/65R33 XLD D2★	kg	lb	-513	-1131	-363	-800	-326	-720
35/65R33 RL5E★	kg	lb	+172	+78	+120	+54	+110	+50

## DIMENSIONS AFFECTED BY TIRE SIZE

MACHINE DIMENSIONS			35/65R33 XRDNAT		35/65-33 (24PR) L-4 (30PR) L-4		35/65-33 (24PR) L-5 (30PR) L-5		35/65R33 XRD1AT XLD D2 RL5E	
			mm	ft in	mm	ft in	mm	ft in	mm	ft in
D	mm	ft in	-19	-1.2"	0	0	+13	+0.5"	+13	+0.5"
F	mm	ft in	-19	-1.2"	0	0	+13	+0.5"	+13	+0.5"
F <sub>1</sub>	mm	ft in	-19	-1.2"	0	0	+13	+0.5"	+13	+0.5"
F <sub>2</sub>	mm	ft in	-19	-1.2"	0	0	+13	+0.5"	+13	+0.5"
H ⊖	mm	ft in	-19	-1.2"	0	0	+13	+0.5"	+13	+0.5"
K	mm	ft in	-19	-1.2"	0	0	+13	+0.5"	+13	+0.5"
L	mm	ft in	-19	-1.2"	0	0	+13	+0.5"	+13	+0.5"
M ⊕	mm	ft in	+19	+0.6"	0	0	-13	0	-13	-0.5"
N ⊕	mm	ft in	+19	+0.6"	0	0	-13	0	-13	-0.2"
T ⊗	mm	ft in	+19	+1.2"	0	0	-13	-0.5"	-13	-0.2"
Y	mm	ft in	0	+0.5"	0	0	0	-0.2"	0	+0.5"
Z	mm	ft in	-19	-1.2"	0	0	+13	+0.5"	+13	+0.5"
a <sub>2</sub>	mm	ft in	0	+0.2"	0	0	0	-0.1"	0	+0.2"
a <sub>3</sub>	mm	ft in	0	+0.2"	0	0	0	-0.1"	0	+0.2"

\* Counterweight #1 and Counterweight #2 cannot be used together.



## OPERATIONAL DATA - MICHIGAN L320 (Long Boom)

**Tires: 35/65-33 (30PR) L-4**

BUCKET TYPE		Straight Edge Rock	S.E. Rock w/Teeth*	S.E. Rock w/BOE	S.E. Rock w/Teeth & Wear Caps*	Spade Nose Rock	S.N. Rock w/Teeth*	S.N. Rock w/BOE	S.N. Rock w/Teeth & Wear Caps*	Light Material	Light material w/BOE
Volume, heaped	m <sup>3</sup>	5,7	5,7	6,0	5,9	5,7	5,7	6,0	5,9	11,5	11,8
	yd <sup>3</sup>	7.5	7.5	7.9	7.7	7.5	7.5	7.9	7.7	15.0	15.4
struck	m <sup>3</sup>	4,7	4,7	4,9	5,0	4,9	4,9	5,1	5,0	9,5	9,9
	yd <sup>3</sup>	6.1	6.1	6.4	6.5	6.4	6.4	6.7	6.5	12.6	12.9
Bucket weight	kg	4 195	4 459	4 864	4 686	4 377	4 640	4 842	4 867	4 681	5 294
	lb	9,250	9,830	10,724	10,330	9,650	10,230	10,674	10,730	10,520	11,670
Static tipping load, straight	kg	34 831	34 498	34 173	34 214	34 354	34 020	33 695	33 736	35 272	34 613
	lb	76,789	76,054	75,337	75,427	75,736	75,001	74,281	74,374	77,760	76,308
full turn	kg	30 916	30 619	30 264	30 370	30 469	30 172	29 816	29 923	31 255	30 603
	lb	68,158	67,503	66,720	66,954	67,171	66,516	65,733	65,967	68,904	67,466
Breakout force	kN	490,4	490,4	481,6	478,1	400,5	400,5	391,2	391,1	389,6	383,2
	lbf	110,200	110,200	108,214	107,439	90,000	90,000	87,925	87,890	87,600	86,165
A	mm	10 757	11 093	10 823	11 093	11 074	11 411	11 143	11 411	11 125	11 191
	ft in	35'3.5"	36'4.75"	35'6.1"	36'4.75"	36'4"	37'5.25"	36'6.7"	37'5.25"	36'6"	36'8.6"
H	mm	4 204	3 965	4 158	3 965	4 051	3 813	4 006	3 813	3 962	3 917
	ft in	13'9.5"	13'0.1"	13'7.7"	13'0.1"	13'3.5"	12'6.1"	13'1.7"	12'6.1"	13'0"	12'10.2"
K	mm	5 436	5 436	5 436	5 436	5 436	5 436	5 436	5 436	5 436	5 436
	ft in	17'10"	17'10"	17'10"	17'10"	17'10"	17'10"	17'10"	17'10"	17'10"	17'10"
L	mm	7 493	7 493	7 493	7 493	7 493	7 493	7 493	7 493	7 976	7 976
	ft in	24'7"	24'7"	24'7"	24'7"	24'7"	24'7"	24'7"	24'7"	26'2"	26'2"
M	mm	1 714	1 953	1 760	1 953	1 905	2 144	1 951	2 144	1 968	2 014
	ft in	5'7.5"	6'4.9"	5'9.3"	6'4.9"	6'3"	7'0.4"	6'4.8"	7'0.4"	6'5.5"	6'7.3"
N	mm	2 730	2 969	2 776	2 969	2 870	3 109	2 916	3 109	2 934	2 979
	ft in	8'11.5"	9'8.9"	9'1.3"	9'8.9"	9'5"	10'2.4"	9'6.8"	10'2.4"	9'7.5"	9'9.3"
T	mm	84	150	122	150	84	150	122	150	84	122
	ft in	3.3"	5.9"	4.8"	5.9"	3.3"	5.9"	4.8"	5.9"	3.3"	4.8"
V	mm	3 962	3 962	3 962	3 962	3 962	3 962	3 962	3 962	4 446	4 446
	ft in	13'0"	13'0"	13'0"	13'0"	13'0"	13'0"	13'0"	13'0"	14'7"	14'7"
a <sub>1</sub> Clearance circle (over bucket in carry position)	mm	18 313	18 313	18 313	18 313	18 313	18 313	18 313	18 313	18 872	18 872
	ft in	60'1"	60'1"	60'1"	60'1"	60'1"	60'1"	60'1"	60'1"	61'11"	61'11"
Operating weight	kg	47 649	47 912	48 116	48 139	47 830	48 093	48 284	48 320	48 225	48 884
	lb	105,046	105,626	106,077	106,126	105,446	106,026	106,447	106,526	106,316	107,768

\*#47 ARL Teeth. Other teeth may affect dimensions differently. Dimensions measured to tips of teeth.  
 Bolt-on-Edge (BOE) adds 0.3m<sup>3</sup> (0.4yd<sup>3</sup>) to heaped capacity.  
 Maximum Grading Angle = 46°





## OPERATIONAL DATA & DIMENSIONS - MICHIGAN L320 (Standard Boom)

### Tires: 35/65-33 (30PR) L-4

Wherever applicable, specifications are in accordance with SAE Standards J732 and J742. Changes from the standard configuration may change machine dimensions and operating data. Operating weight is approximate and includes the bucket given in the table, ROPS canopy, cab, all standard equipment, and counterweight #1.

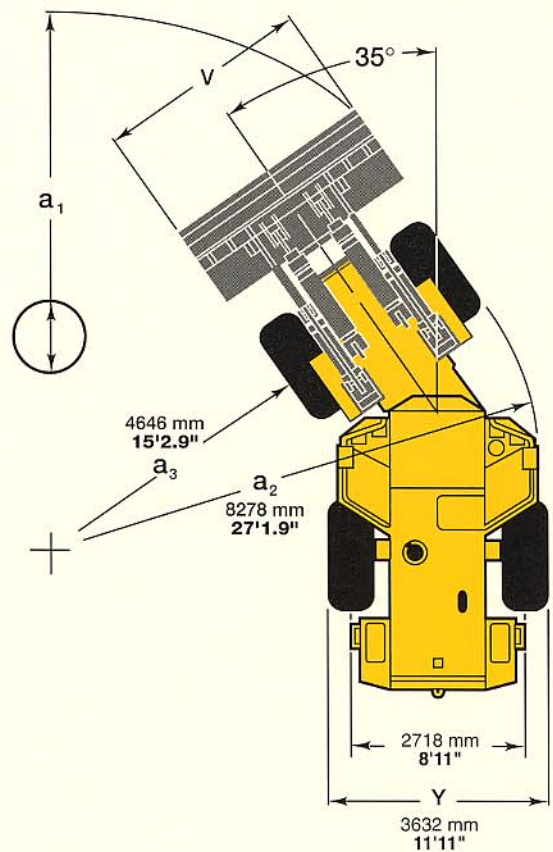
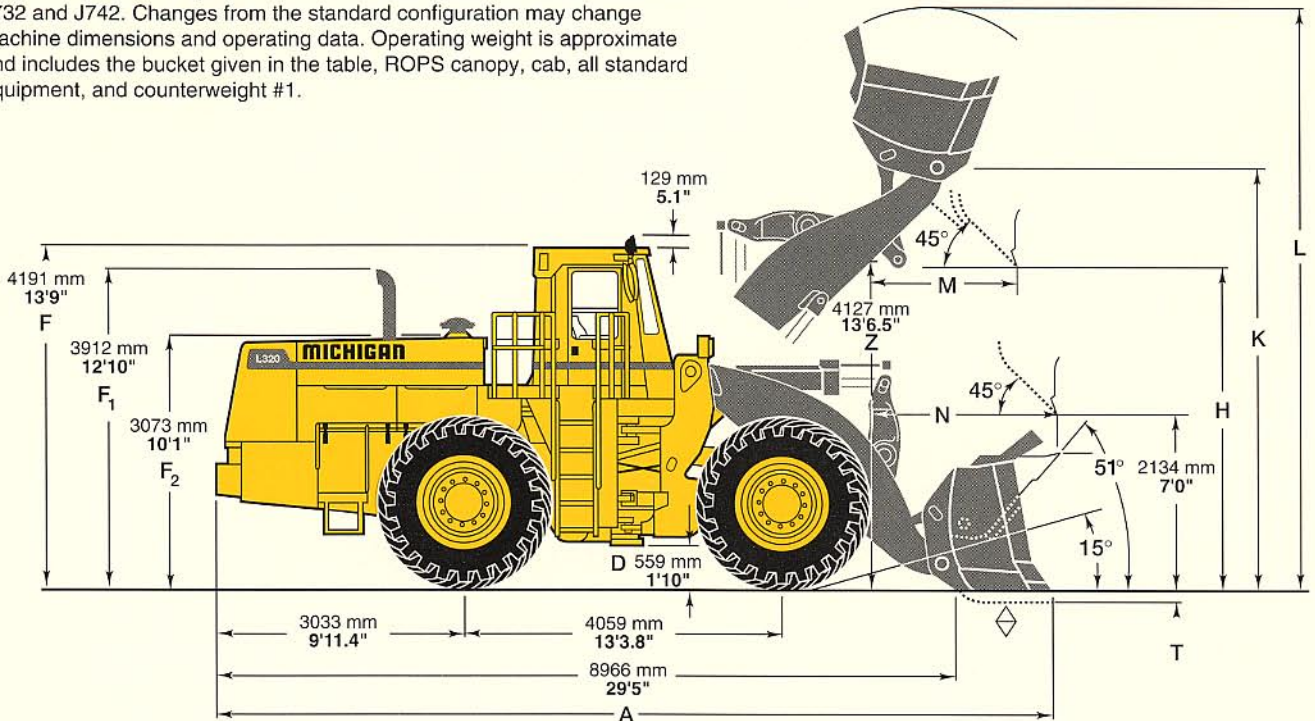



## STANDARD EQUIPMENT

<p>AIR CLEANER, DRY TYPE, DUAL ELEMENT WITH EXHAUST ASPIRATED PRECLEANER</p> <p>ALTERNATOR, 24V, 100A</p> <p>BATTERY DISCONNECT, LOCKABLE</p> <p>BOOM &amp; BUCKET CONTROL LEVERS, FINGERTIP</p> <p>BOOM &amp; BUCKET LINKAGE, SEALED PINS</p> <p>BOOM KICKOUT, AUTOMATIC, ADJUSTABLE</p> <p>BRAKE SYSTEM, SECONDARY BRAKES, 4-WHEEL HYDRAULIC WET DISC, LIQUID COOLED</p> <p>BUCKET LEVELER, AUTOMATIC</p> <p>CAB ACCESS STEPS &amp; HANDRAILS (SAE J185)</p> <p>CAB, Non-ROPS</p> <p>Accessory Power Converter, 12V/3A</p> <p>Acoustical Lining</p> <p>Door Hold-Open Struts (2)</p> <p>Doors (2); Lockable with self-locking, sliding glass windows</p> <p>Electrical System: 24V, circuit breaker protected, pre-wired for optional accessories</p> <p>Environmental Control: Air Conditioner kW 6,3 (Btu/h 21,000)</p>	<p>Heater/Defroster/Pressurizer with three-speed blower fan kW 12,3 (Btu/h 42,000)</p> <p>Floor Mat</p> <p>Interior Lights, red &amp; white</p> <p>Interior Rearview Mirror</p> <p>Retractable Seat Belt (SAE J386)</p> <p>Safety Glass, Tinted</p> <p>Seat, air suspension, 6-way adjustable</p> <p>Steering Wheel Spinner Knob</p> <p>Sun Visor</p> <p>Windshield Wiper &amp; Washer, front &amp; rear</p> <p>COLD START AID, ETHER INJECTION</p> <p>DIFFERENTIALS, LIMITED SLIP, FRONT &amp; REAR</p> <p>DRAWBAR WITH PIN</p> <p>DRIVESHAFT GUARD</p> <p>FRAME, BOTTOM ENCLOSURES</p> <p>GRILLE, REAR SWING-OUT</p> <p>HYDRAULIC FLUID TO AIR COOLER</p> <p>HYDRAULIC PRESSURE TEST PORTS, QUICK CONNECT</p> <p>INSTRUMENTS/GAUGES: Air Cleaner Restriction Indicator</p> <p>Engine Coolant Temperature Gauge</p> <p>Engine Oil Pressure Gauge</p>	<p>Fuel Gauges, tank and dash mounted</p> <p>Hourmeter</p> <p>Sight Gauges: Engine Coolant Level</p> <p>Hydraulic Fluid Level</p> <p>Transmission Fluid Level</p> <p>Transmission/Torque Converter Fluid Temperature Gauge</p> <p>Voltmeter</p> <p>ISOLATION MOUNTS: Cockpit, Engine, Radiator, Transmission</p> <p>LIGHTS: Stop &amp; Tail Combination, 2 rear</p> <p>Work, 4 front, 4 rear (60 watt halogen)</p> <p>LUBRICATION, MANIFOLD TYPE, GROUND ACCESSIBLE</p> <p>MIRRORS, REARVIEW (2), EXTERIOR</p> <p>NEUTRAL START FEATURE</p> <p>REMOTE DRAIN FOR ENGINE OIL, COOLANT &amp; TRANSMISSION FLUID</p> <p>ROPS/FOPS CANOPY (SAE 1040, ISO 3471) (SAE J231, ISO 3449)</p> <p>SIDE PANELS, ENGINE HOOD, LOCKABLE</p> <p>STEERING FRAME LOCK</p> <p>TIRES: 35/65-33 (30PR) L-4</p>	<p>TRANSMISSION: Declutch pedal with dash mounted on/off switch</p> <p>Powershift, with directional clutch modulation</p> <p>Shift Control, single lever electric</p> <p>VANDALISM LOCK, PROVISION FOR: Batteries, Engine Coolant, Fuel, Hydraulic Fluid, Transmission/Torque Converter Fluid</p> <p>WARNING ALARMS: Horn, electric</p> <p>Reverse Alarm (SAE J994)</p> <p>WARNING &amp; MONITORING LIGHTS: Air Conditioner Malfunction</p> <p>Alternator Malfunction</p> <p>Brake Pump/Differential Pressure Brake System, front</p> <p>Brake System, rear</p> <p>Engine Coolant Temperature</p> <p>Engine Oil Pressure</p> <p>Hydraulic Fluid Temperature</p> <p>Low Fuel Level</p> <p>Parking Brake Applied</p> <p>Transmission Filter Restriction</p> <p>Transmission Temperature</p>
---	---	---	---

## OPTIONAL EQUIPMENT (May be standard in certain markets)

<p>Accessory Power Converter, 12V/6A</p> <p>Air Conditioner (Removal)</p> <p>Beacon, Rotating, Amber</p> <p>Bucket (See Operational Data): Bolt-on Cutting Edge</p> <p>Cutting Edge Wear Caps</p> <p>Points &amp; Adapters</p> <p>Cab (Removal)</p> <p>Canopy, Open ROPS/FOPS</p> <p>Counterweight #1 1161 kg (2560 lb)</p> <p>Counterweight #2 873 kg (1926 lb)</p> <p>Engine Oil Fill &amp; Evacuation (Wiggins)</p> <p>Engine Preheater, Coolant &amp; Oil</p>	<p>(120V &amp; 240V)</p> <p>Engine Shutdown to Idle Kit: High Coolant Temperature</p> <p>Low Engine Oil Pressure</p> <p>European Accessory Package</p> <p>Fan, reversible</p> <p>Fenders, front</p> <p>Fenders, rear with steps</p> <p>Fire Extinguisher</p> <p>Fuel, Fast Fill Coupler (Wiggins)</p> <p>Gauge, Hydraulic Fluid Level</p> <p>Guards: Grille</p> <p>Transmission</p> <p>Windshield</p> <p>Hydraulic Control, 3 Spool Valve, Piping &amp; Controls</p>	<p>Hydraulic Fluid Fill &amp; Evacuation (Wiggins)</p> <p>Instrument Cover Kit (ROPS/FOPS Canopy)</p> <p>Lights, work, (2), extra, hood-mounted (60 watt halogen)</p> <p>Logger Package</p> <p>Lubrication System, automatic (Trabon)</p> <p>Lubrication System, single point manual (Trabon)</p> <p>Mud Flaps (2), front, use with front fenders</p> <p>Radiator, L &amp; M</p> <p>Radiator Sand Grid</p> <p>Radiator Shutter Kit</p> <p>Reversible Fan</p> <p>ROPS Canopy (SAE J1040)</p>	<p>(ISO 3471) (Removal)</p> <p>Secondary Steering (Electric)</p> <p>Side Panels, Wire Mesh</p> <p>Tiefbau Kit (for German Regulations)</p> <p>Warning &amp; Monitor Lights: Coolant Level</p> <p>Hydraulic Filter Restriction Indicator with Low Hydraulic Fluid Level Warning</p> <p>Tires: 35/65-33 (24PR) L-4</p> <p>35/65-33 (24PR) L-5</p> <p>35/65-33 (30PR) L-5</p> <p>35/65R33 XRDNAT ★</p> <p>35/65R33 XRD1AT ★</p> <p>35/65R33 XLD D2 ★</p> <p>35/65R33 RL5E</p>
---	--	---	--

*Under our policy of continuous product improvement, we reserve the right to change specifications and design without prior notice. The illustrations do not necessarily show the standard version of the machine.*

**VME Industries Sweden AB**

S-631 85 ESKILSTUNA SWEDEN

Ref. No. 21 1 669 3003

DATE 12/93

Printed in U.S.A.