

**MICHIGAN**

# L270



- **Engine output:**  
SAE J1349 Net      269 kW (360 hp)
- **Operating weight:** 41,3 t (91 070 lb)
- **Buckets:**                      5,35 m<sup>3</sup> (7,0 yd<sup>3</sup>)

**Robust high-capacity loader for tough digging**

- **Rugged in-line Z-bar linkage**  
- high breakout forces, high lift height, long reach

- **Reliable countershaft transmission**  
- quick and smooth shifting between forward and reverse

- **Productivity-boosting hydraulic system** - the power is directed to where it is needed at every instant. Quick and precise control of the unit

- **Limited slip differentials**  
Optimum traction. Minimal wheel spin and tire wear.

## ENGINE



The engine is a 6 cylinder, inline, direct injected 4 stroke, turbocharged diesel engine.

**Air cleaning:** Air cleaning in three stages.

1. Cyclone precleaner, exhaust aspirated.
2. Paper filter with restriction indicator.
3. Replaceable safety filter element.

Make		Cummins	
Model		KT-19-C	
Max rating* at	r/s (r/min)	35	(2100)
SAE J1349 / ISO 1585	kW (hp)	298,3	(400)
Flywheel rating** at	r/s (r/min)	35	(2100)
SAE J1349 / ISO 1585	kW (hp)	269	(360)
DIN 70020	kW (hp)	269	(360)
Max. torque at	r/s (r/min)	25	(1500)
SAE J1349 / ISO 1585	Nm (lbf ft)	1830	(1350)
DIN 70020	Nm (lbf ft)	1830	(1350)
Number of cylinders		6	
Displacement, total	l (in <sup>3</sup> )	18,8	(1150)
Bore	mm (in)	158,8	(6,25)
Stroke	mm (in)	158,8	(6,25)

\* **Max. rating** - Rating of engine equipped only with components essential for engine function, such as injection pump, oil pump and water pump.

\*\* **Flywheel rating** - Net rating measured with fan, intake and exhaust system, cooling system and alternator mounted.

## DRIVE TRAIN



**Torque converter:** Clark high-efficiency, single-stage single phase.

**Transmission:** Clark countershaft type powershift transmission with directional clutch modulation.

**Axes:** Clark fully-floating axle shafts with planetary-type hub reductions. Single piece cast axle housings. Fixed front axle and oscillating rear axle.

**Differential:** Clark limited slip differentials on front and rear axles.

**Hub reductions:** Clark planetary drive with low-friction bearings in each wheel hub.

**Tires:** Alternative tires available for different applications.

Torque converter		3,050:1	
Speeds			
forward/reverse			
1	km/h (mile/h)	6,8	(4,2)
2	km/h (mile/h)	11,9	(7,4)
3	km/h (mile/h)	20,1	(12,5)
4	km/h (mile/h)	34,6	(21,5)
With tires		29.5-29	
		(28PR) L-4	
Rear axle oscillation	± °	12	
Total	mm (in)	559	(22,0)

## ELECTRICAL SYSTEM



The electrical system is well protected by circuit breakers. Prewired for optional equipment.

**Warning system:** Warning system monitors pressure in front/rear brakes and brake pump, parking brake, air conditioner and transmission filter restriction.

Voltage	V	24
Alternator	A	100
Cold cranking capacity	A	1250

## SERVICE REFILL CAPACITIES



Crankcase	l (US gal)	41,6	(11,0)
Fuel tank	l (US gal)	711,6	(188,0)
Cooling system	l (US gal)	98,4	(26,0)
Transmission total	l (US gal)	72,0	(19,0)
Differentials (each)	l (US gal)	60,5	(16,0)
Hubs (each)	l (US gal)	9,5	(2,5)
Midmount bearing	l (US gal)	4,7	(1,25)
Hydraulic system, total	l (US gal)	454,2	(120,0)
Hydraulic tank	l (US gal)	348,0	(92,0)

## BRAKE SYSTEM



(SAE J1152) (ISO 3450)

**Service brakes:** Full hydraulic system with outboard mounted dry disc brakes. Application of left pedal switches transmission from forward to neutral.

**Secondary:** Dual circuit axle-by-axle system. Manually activated by service brake pedals. Audible and visual low pressure alarm. Dead engine braking capability provided by two nitrogen pre-charged accumulators.

**Parking brake:** Dry disc type mounted on front axle input shaft. Spring applied, hydraulically released; activated by switch on instrument panel. With parking brake applied and engine running, transmission interlock applies service brakes to prevent machine moving when shifted into forward or reverse.

**Pump:** Piston pump, pressure compensated.

**Filtration:** Full-flow filtration, 10 µm filter.

Pump	MPa (psi)	20,7	(3000)
Brake disc			
Outside diameter	mm (in)	571,5	(22,5)
Inside diameter	mm (in)	279,4	(11,0)
Thickness	mm (in)	15,9	(0,625)
Parking brake disc			
diameter	mm (in)	457,1	(18,0)
thickness	mm (in)	12,7	(0,5)

# DIMENSIONS MICHIGAN L270

Tires: 29.5-29 (28 PR) L-4

Wherever applicable, specifications are in accordance with SAE Standard J732 and J742. Changes in the standard configuration may change machine dimensions and operating data. Operating weight is approximate and includes the bucket given in the table, ROPS cab, all standard equipment and 3447 kg (7600 lb) counterweight.

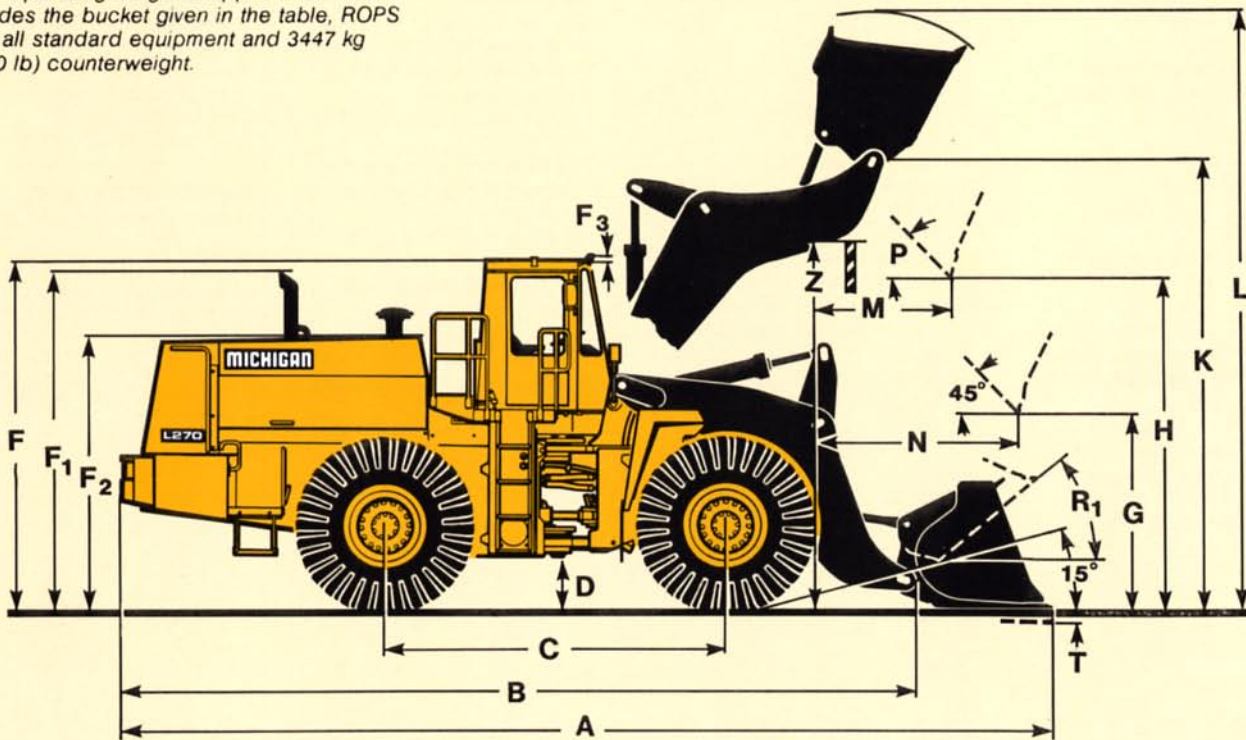

## Bucket type

- 1 General purpose-straight-edge rock
- 2 Spade-nose rock
- 3 Material handling

- ⊖ Deduct 254 mm (10 in) for bucket teeth
- ⊕ Add 162 mm (6 in) for bucket teeth
- ⊕ Add 51 mm (2 in) for bucket teeth

Bucket type		1	2	3
Volume, heaped	m <sup>3</sup>	5,35	5,35	6,12
	(yd <sup>3</sup> )	(7,0)	(7,0)	(8,0)
struck	m <sup>3</sup>	4,5	4,5	5,3
	(yd <sup>3</sup> )	(5,9)	(5,9)	(6,9)
Volumetric weight	kg/m <sup>3</sup>	1780	1780	1558
	(lb/yd <sup>3</sup> )	(3000)	(3000)	(2625)
Bucket weight	kg	3801	4013	3606
	(lb)	(8380)	(8848)	(7950)
Operating capacity	kg	9525	9525	9525
	(lb)	(21 000)	(21 000)	(21 000)
Static tipping load, straight	kg	25 710	25 442	26 570
	(lb)	(56 680)	(56 090)	(58 575)
Full turn	kg	22 685	22 444	23 476
	(lb)	(50 010)	(49 480)	(51 755)
Breakout force	kN	355,8	306,9	345,7
	(lbf)	(80 000)	(69 000)	(77 714)
A	mm	10 236	10 465	10 312
	(ft in)	(33'7")	(34'4")	(33'10")
H	mm	3734 ⊖	3581 ⊖	3673 ⊖
	(ft in)	(12'3")	(11'9")	(12'1")
L	mm	6960	6960	6756
	(ft in)	(22'10")	(22'10")	(22'2")
M	mm	1702 ⊕	1880 ⊕	1689 ⊕
	(ft in)	(5'7")	(6'2")	(5'6")
N	mm	2540 ⊕	2692 ⊕	2532 ⊕
	(ft in)	(8'4")	(8'10")	(8'4")
T	mm	152 ⊖	152 ⊖	152 ⊖
	(ft in)	(6")	(6")	(6")
V	mm	3759	3759	3759
	(ft in)	(12'4")	(12'4")	(12'4")
a <sub>1</sub> Turning circle (over bucket)	mm	17 120	17 247	17 170
(bucket in carry position)	(ft in)	(56'2")	(56'7")	(56'4")
Operating weight	kg	41 309	41 523	41 114
	(lb)	(91 070)	(91 540)	(90 640)

B	mm (ft in)	8648 (28'4,5")
C	mm (ft in)	3759 (12'4")
D	mm (ft in)	559 (1'10")
F	mm (ft in)	3912 (12'10")
F <sub>1</sub>	mm (ft in)	3835 (12'7")
F <sub>2</sub>	mm (ft in)	3023 (9'11")
F <sub>3</sub>	mm (ft in)	64 (2,5")
G	mm (ft in)	2134 (7'0")
K	mm (ft in)	5004 (16'5")
P	°	45
R <sub>1</sub>	°	50
X	mm (ft in)	2680 (8'9,5")
Y	mm (ft in)	3454 (11'4")
Z	mm (ft in)	4001 (13'1,5")
a <sub>2</sub>	mm (ft in)	7747 (25'5")
a <sub>3</sub>	mm (ft in)	4242 (13'11")
a <sub>4</sub>	± °	35

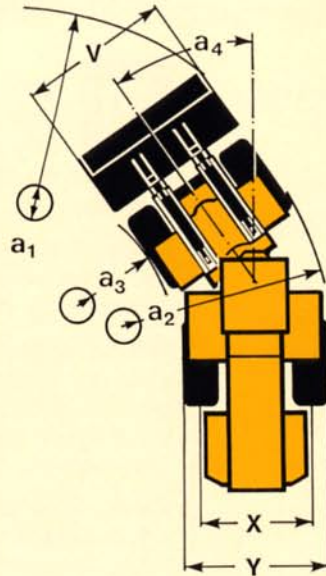

### MACHINE DIMENSIONS WITH ALTERNATIVE TIRES

With general purpose bucket

		29.5-29 (L-2)	29.5-29 (L-3)	29.5R29 (L-5)	35/65-33 (L-4)	35/65-33 (L-5)
D	mm (ft in)	521 (1'8,5")	533 (1'9")	584 (1'11")	584 (1'11")	584 (1'11")
F	mm (ft in)	3886 (12'9")	3886 (12'9")	3937 (12'11")	3937 (12'11")	3937 (12'11")
F <sub>1</sub>	mm (ft in)	3797 (12'5,5")	3810 (12'6")	3861 (12'8")	3861 (12'8")	3861 (12'8")
F <sub>2</sub>	mm (ft in)	2985 (9'9,5")	2997 (9'10")	3048 (10'0")	3048 (10'0")	3048 (10'0")
H	mm (ft in)	3708 (12'2")	3708 (12'2")	3759 (12'4")	3759 (12'4")	3759 (12'4")
K	mm (ft in)	4978 (16'4")	4978 (16'4")	5029 (16'6")	5029 (16'6")	5029 (16'6")
L	mm (ft in)	6934 (22'9")	6934 (22'9")	6985 (22'11")	6985 (22'11")	6985 (22'11")
M	mm (ft in)	1727 (5'8")	1727 (5'8")	1676 (5'6")	1676 (5'6")	1676 (5'6")
N	mm (ft in)	2565 (8'5")	2565 (8'5")	2527 (8'3,5")	2515 (8'3")	2515 (8'3")
T	mm (ft in)	191 (7,5")	178 (7")	127 (5")	127 (5")	127 (5")
Y	mm (ft in)	3454 (11'4")	3454 (11'4")	3454 (11'4")	3581 (11'9")	3581 (11'9")
Z	mm (ft in)	4001 (13'1,5")	4013 (13'2")	4064 (13'4")	4064 (13'4")	4064 (13'4")
a <sub>2</sub>	mm (ft in)	7747 (25'5")	7747 (25'5")	7747 (25'5")	7823 (25'8")	7823 (25'8")
a <sub>3</sub>	mm (ft in)	4242 (13'11")	4242 (13'11")	4242 (13'11")	4166 (13'8")	4166 (13'8")

### SUPPLEMENTAL OPERATING DATA

		Change in operating weight		Change in static tipping load at full turn		Change in static tipping load straight	
Bucket teeth (std opt)	kg (lb)	+ 218	(480)	- 240	(531)	- 277	(610)
Counterweight	kg (lb)	+ 1089	(2400)	+ 1842	(4060)	+ 2105	(4640)
Removal of cab	kg (lb)	- 817	(1800)	- 508	(1120)	- 581	(1280)
Fenders, front	kg (lb)	+ 118	(260)	+ 23	(50)	+ 27	(60)
Alternative tires:							
29.5-29 (28 PR) L-3	kg (lb)	- 708	(1560)	- 390	(860)	- 445	(980)
29.5-29 (28 PR) L-5	kg (lb)	+ 671	(1480)	+ 367	(810)	+ 422	(930)
29.5-29 (28 PR) L-5 HT	kg (lb)	+ 780	(1720)	+ 431	(950)	+ 490	(1080)
29.5-29 (28 PR) L-5 S	kg (lb)	+ 894	(1970)	+ 494	(1090)	+ 562	(1240)
29.5-29 (34 PR) L-3	kg (lb)	- 499	(1100)	- 272	(600)	- 313	(690)
29.5 R 29 XRDNAT*	kg (lb)	- 839	(1850)	- 463	(1020)	- 526	(1160)
29.5 R 29 XRBT**	kg (lb)	- 1247	(2750)	- 680	(1500)	- 780	(1720)
29.5 R 29 XRD1AT*	kg (lb)	- 408	(900)	- 222	(490)	- 254	(560)
29.5 R 29 XRAT*	kg (lb)	- 1002	(2210)	- 553	(1220)	- 631	(1390)
29.5 R 29 RL-2F** L-2	kg (lb)	- 1025	(2260)	- 562	(1240)	- 644	(1420)
29.5 R 29 RL-3** L-3	kg (lb)	- 145	(320)	- 82	(180)	- 91	(200)
35/65-33 (24 PR) L-4	kg (lb)	+ 195	(430)	+ 109	(240)	+ 122	(270)
35/65-33 (24 PR) L-5	kg (lb)	+ 839	(1850)	+ 463	(1020)	+ 526	(1160)
35/65-33 (24 PR) L-5 HT	kg (lb)	+ 948	(2090)	+ 552	(1150)	+ 594	(1310)
35/65-33 (24 PR) L-5 S	kg (lb)	+ 1057	(2330)	+ 581	(1280)	+ 662	(1460)
35/65-33 (30 PR) L-4	kg (lb)	+ 807	(1780)	+ 445	(980)	+ 508	(1120)
35/65-33 (30 PR) L-5	kg (lb)	+ 1497	(3300)	+ 821	(1810)	+ 939	(2070)
35/65-33 (30 PR) L-5 S	kg (lb)	+ 1715	(3780)	+ 939	(2070)	+ 1075	(2370)
35/65 R 33 XRDNAT*	kg (lb)	- 286	(630)	- 159	(350)	- 181	(400)
35/65 R 33 XRD1AT*	kg (lb)	+ 209	(460)	+ 113	(250)	+ 132	(290)
35/65 R 33 XRD2AT*	kg (lb)	+ 862	(1900)	+ 472	(1040)	+ 540	(1190)
35/65 R 33 RL-5E* L-5	kg (lb)	+ 962	(2120)	+ 526	(1160)	+ 603	(1330)

► Note: Tire chains cannot be used with 35/65-33 tires.

## STEERING SYSTEM



Articulated frame. Fully hydraulic steering system with speed sensor hydraulics.

**Pump:** Fixed displacement gear-type mounted on torque converter, augmented by variable displacement piston pump mounted on torque converter.

**Supply system:** The system is served by the large steer pump and the piston pump which is rpm and pressure sensitive and feeds either the main hydraulic or the steering system.

**Cylinders:** Two double acting cylinders with chrome plated piston rods.

Steer cylinders			2	
Bore	mm	(in)	127	(5,0)
Stroke	mm	(in)	496,8	(19,56)
Relief pressure	MPa	(psi)	19,3	(2800)
Primary pump				
Output	l/min		322	
	(US gal/min)			(85)
at	MPa	(psi)	6,9	(1000)
and engine speed	r/s	(r/min)	35	(2100)
Secondary pump				
Output	l/min		102,2	
	(US gal/min)			(27,0)
at	MPa	(psi)	6,9	(1000)
and engine speed	r/s	(r/min)	35	(2100)

## CAB



Integral ROPS/FOPS cab (SAE J1040, ISO 3471). Sound-insulating lining. Floor mats. Two lockable doors. Sliding self-locking windows. Tinted safety glass.

**Heater and defroster:** Heater provides filtered (10 µm) fresh air and has three-speed fan and a defroster for the front and side windows. Air conditioning is standard.

**Operator's seat:** Fully adjustable suspension seat with seat belt (SAE J386).

Noise level				
in cab	dB (A)		83	
Heating capacity	kW	(Btu/h)	11	(37 500)
Air conditioning	kW	(Btu/h)	5,9	(20 000)

## HYDRAULIC SYSTEM



Closed and pressurized load-sensing system with a sturdy plate-steel tank. Hydraulic oil is fully filtered and cooled.

Access hole in tank for easy cleaning. In-tank magnet provides extra protection.

**Pump:** Fixed displacement gear type mounted on torque converter, augmented by variable displacement piston pump mounted on torque converter.

**Supply system:** The system is served by the large main pump and the piston pump which is pressure and rpm sensitive and feeds either the main hydraulic or the steering system, depending on system requirements.

**Valve:** Split spool valve with built-in pressure relief valve. Actuated by a pilot valve, it is mounted on front frame for easy access.

**Lift function:** The valve has four positions: Raise, hold, lower and float. An automatic kickout detent is adjustable for any position between maximum reach and full lift height.

**Tilt function:** The valve has three positions: Rollback, hold and dump. An automatic bucket positioner adjusts to any desired loading angle.

**Cylinders:** Double-acting.

**Filters:** Full flow 10 µm return filter (with four elements).

Relief pressure	MPa	(psi)	19,0	(2750)
Output	l/min		677,5	
	(US gal/min)			(179)
at	MPa	(psi)	6,9	(1000)
and engine speed	r/s	(r/min)	35	(2100)
Lift cylinders			2	
Bore	mm	(in)	228,6	(9,0)
Stroke	mm	(in)	1140,5	(44,9)
Tilt cylinders			2	
Bore	mm	(in)	190,5	(7,5)
Stroke	mm	(in)	784,9	(30,9)
Raising time (with load)	s		8,6	
Dumping time (with load)	s		3,0	
Lowering time (empty)	s		5,0	
Total cycle time	s		16,6	

## STANDARD EQUIPMENT

### Safety & comfort

ROPS/FOPS cab  
(SAE J1040, ISO 3471)  
sound insulated and airtight  
Lockable doors with self-locking sliding glass windows  
Door hold-open struts  
Prewired for optional accessories  
Cab heating with filtered fresh air intake and defroster  
Air conditioner  
Floor mats  
Interior lighting, red & white  
Tinted safety glass  
Seat belt (SAE J386)  
Adjustable suspension seat  
Steering wheel with spinner knob  
Sun visor  
Windshield washers, front/rear  
Windshield wipers, front/rear  
Cab access steps and handrails (SAE J185)  
Mirrors, rear view, two exterior  
Mirror, rear view, one interior  
Drive shaft guard, converter to transmission  
Grille, rear swing-out

Steering frame lock  
Dual-circuit brake system with dry disc brakes on all wheels  
Brake system, secondary  
Hood side panels, lockable  
Vandalism lock, provision for:  
Batteries  
Engine coolant  
Fuel  
Hydraulic fluid  
Transmission/converter fluid  
Isolation mounts:  
Cab  
Engine  
Radiator  
Transmission  
Working lights (70 W), 4 front, 4 rear  
Stop and turn combination, 2 rear  
Turn signals with hazard warning switch  
Lubrication system, manifold type, ground accessible  
Drawbar with pin  
Sealed hinge pins  
Horn  
Reverse alarm (SAE J994)  
Lifting lugs

### Engine & electrical system

Electrical system (24 V)  
Alternator (100 A)  
Lockable battery disconnect  
Safety start, neutral safety start  
Cold start aid ether  
Instruments/gauges  
Air cleaner restriction indicator  
Engine coolant temperature  
Engine oil pressure  
Fuel gauge on tank and dash  
Hour meter  
Transmission/torque converter fluid temperature gauge  
Voltmeter  
Warning & monitoring lights/audible alarm:  
Air conditioner malfunction  
Parking brake applied  
Brake pump/differential pressure  
Brake system, front  
Brake system, rear  
Transmission filter restriction

Sight gauges:  
Engine coolant  
Hydraulic fluid level  
Transmission fluid level

### Drivetrain

Limited slip differentials in front and rear axles  
Power shift transmission with directional clutch modulation  
Transmission declutch  
Tires: 29.5-29 (28 PR) L-4

### Hydraulic system

Quick-connect hydraulic test ports  
Hydraulic fluid to air cooler  
Automatic boom kickout  
Automatic bucket positioner

## OPTIONAL EQUIPMENT (Standard on certain markets)

### Engine equipment

Cold starting aid:  
preheater coolant and oil  
Radiator sand grid  
Engine shutdown to idle kit  
Oil evacuation kit (Wiggins)

### Electrical equipment

Rotating beacon

### Cab equipment

Instrument cover kit  
Warning & monitor lights  
Low engine oil pressure  
Low engine coolant level  
High engine coolant temperature

### Hydraulic equipment

3rd hydraulic control  
Hydraulic fluid fill & evacuation

### Exterior equipment

Fenders, front with mud flaps, front  
Counterweight, 1090 kg (2 400 lb)

### Other equipment

Secondary steering (electrical)  
Open ROPS, 4 post  
Coupler, fast fuel kit (Wiggins)  
Quick fill hydraulic oil (Wiggins)

### Tires

29.5-29 (28 PR) L-3  
29.5-29 (28 PR) L-5  
29.5-29 (28 PR) L-5 HT  
29.5-29 (28 PR) L-5 S  
29.5-29 (34 PR) L-3  
29.5 R 29 XRDNAT\*  
29.5 R 29 XRBT\*\*  
29.5 R 29 XRD1AT\*

29.5 R 29 XRAT\*  
29.5 R 29 RL-2F\*\* L-2  
29.5 R 29 RL-3\*\* L-3  
35/65-33 (24 PR) L-4  
35/65-33 (24 PR) L-5  
35/65-33 (24 PR) L-5HT  
35/65-33 (24 PR) L-5S  
35/65-33 (30 PR) L-4  
35/65-33 (30 PR) L-5  
35/65-33 (30 PR) L-5S  
35/65 R 33 XRDNAT\*  
35/65 R 33 XRD1AT\*  
35/65 R 33 XRD2AT\*  
35/65 R 33 RL-5E\* L-5

Under our policy of continuous product improvement, we reserve the right to change specifications and design without prior notice. The illustrations do not necessarily show the standard version of the machine.

## VME Americas Inc.

23001 EUCLID AVENUE  
P.O. BOX 178017  
CLEVELAND, OHIO 44117-8017

