

**MICHIGAN**

**L 160**

**Compactor**



## **MICHIGAN L 160 COMPACTOR - FOR HIGH CAPACITY**

*The Michigan L160 Compactor is designed to compact and level the large volumes of refuse and waste generated daily.*

*The L160 is extremely versatile - it will doze, carry, breakup and compact the waste and when compaction is completed; dig, carry and spread cover material. It has large, effective compactor wheels, plus underbody and side protection plates to guard against damage to vulnerable points.*

*The machine is both stable and highly maneuverable due to uniform weight distribution and has a loader unit combining large lifting and breakout forces with long reach.*

*The cab is quiet with a high-capacity filtered, pressurized, heated, air conditioned, and fresh-air ventilation system. This creates a comfortable, superb working environment for the operator.*

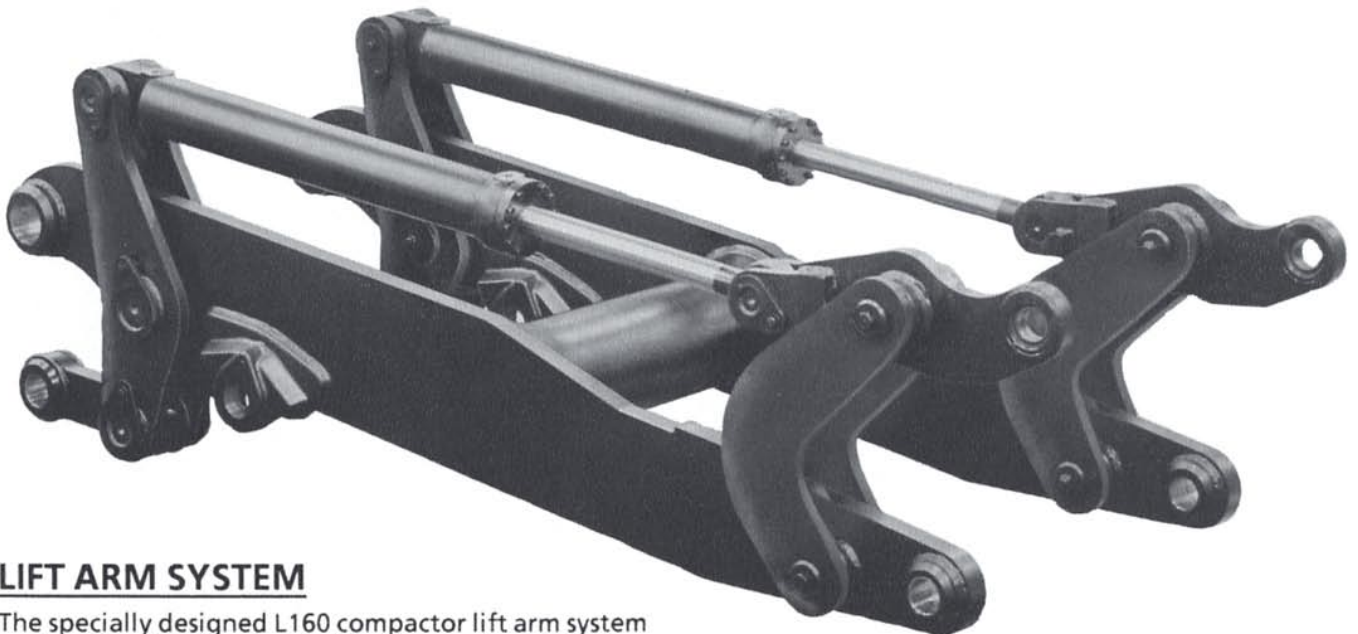

### **LIFT ARM SYSTEM**

The specially designed L160 compactor lift arm system enables it to be fitted with either a standard 4,0 m<sup>3</sup> (5.2 yd<sup>3</sup>) trash bucket, or the versatile multi-purpose bucket.

The L160 compactor can dig it's own cover, and spread it in a very efficient, economical way. With the multi-purpose bucket, even, controlled, spreading of cover is possible, using a partially open bucket to control the flow. This opening-clamp feature of the multi-purpose bucket also enables the machine to safely lift and carry large indestructible items of trash

to the correct places on the landfill and to, if required, bottom dump them into trucks.

The pins in the lifting arm system are protected and sealed against the ingress of harmful materials.

The buckets and the lift arms are painted non-reflective "flat black" to avoid glare dazzling the operator when working in night operations with the powerful quartz halogen lights.

## **POWER & ENGINEERING**

Michigan L160 Compactor is equipped with Volvo BM components manufactured to very high standards. High engineering design standards plus stringent production quality control are your assurance to total satisfaction.

In order to achieve good overall economy and maximum machine utilization, a great deal of effort has been devoted to component coordination and extension of service intervals. This results in a reliable efficient, economical high capacity machine.

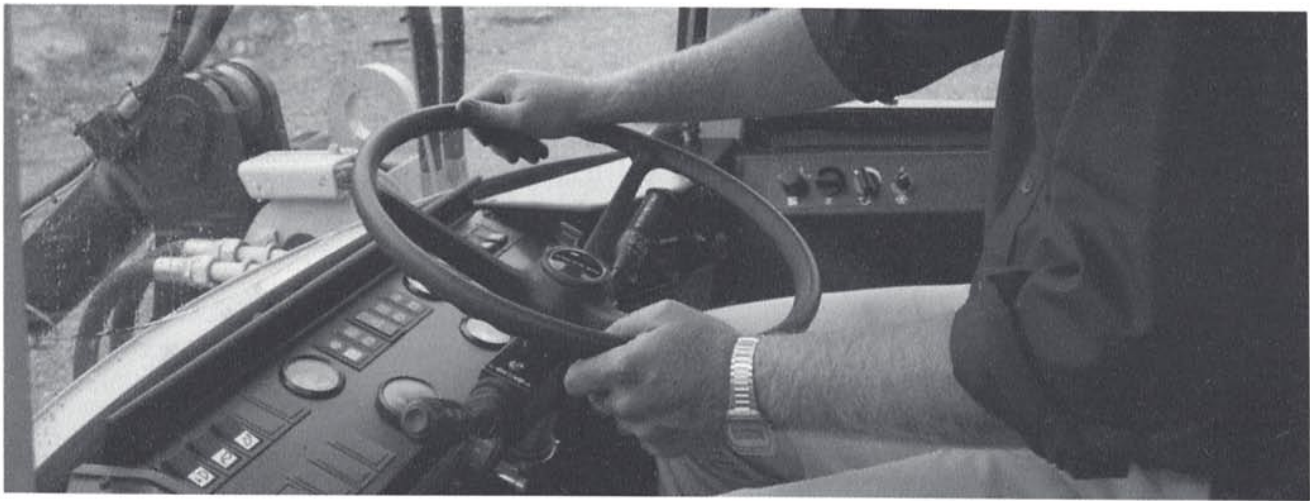
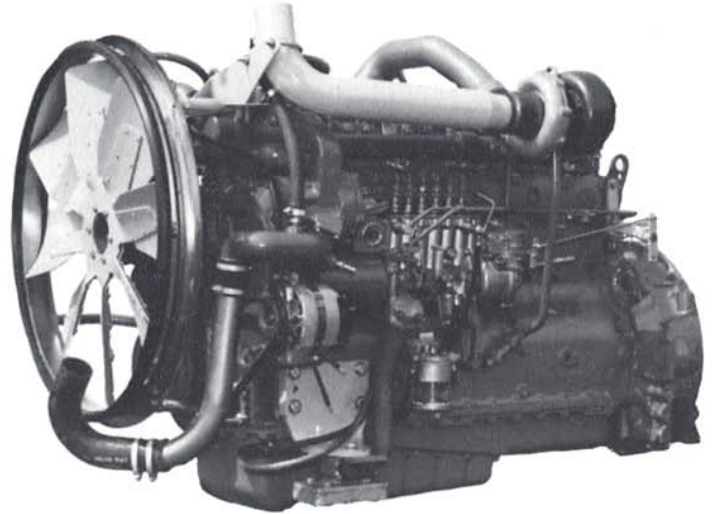

## **CAB**

The Michigan Compactor operator performs his work from an ergonomically designed ROPS, FOPS cab.

The cab is exceptionally comfortable with ideally located controls and instruments. The controls are well positioned, and the instrumentation is visible at a glance. Pilot lamps, instruments and controls are marked with easy identifiable symbols.

A pleasant "indoor" climate can be maintained in the Michigan L160 Compactor cab, regardless of outside weather and job conditions.

The incoming air is cleaned by a large replaceable filter before being drawn into the cab. The pressurized air is distributed throughout the cab by strategically placed nozzles.

The heating system will keep the operator warm in the coldest of weather and the air conditioner will cool the operator in the warmest of operating conditions. This keeps the operator fresh and alert during long working shifts.





## ENGINE

The Volvo TD 101 G is a 6-cylinder, direct-injection, 4-stroke, turbocharged diesel engine with wet, replaceable cylinder liners.

**Air cleaning:** air cleaning in three stages.

1. Cyclone cleaner with automatic exhaust ejector
2. Paper filter with indicator in cab.
3. Replaceable safety filter

Make Model			Volvo TD 101 G	
Output, gross, at SAE J 1349	rps	rpm	36,7	2200
	kW	hp	194	264
Flywheel output at SAE J 1349 Gross	rps	rpm	36,7	2200
SAE J 1349 Net	kW	hp	185	252
DIN 70020/6271	kW	hp	185	252
Max. torque at SAE J 1349 Gross	rps	rpm	23,3	1400
SAE J 1349 Net	Nm	lbf ft	980	723
SAE J 1349 Net	Nm	lbf ft	962	710
DIN 70020/6271	Nm	lbf ft	962	710
No. of cylinders			6	
Displacement, total	dm <sup>3</sup> , l	in <sup>3</sup>	9,6	586
Bore	mm	in	120,65	4,75
Stroke	mm	in	140	5,5
Compression ratio			15:1	



## ELECTRICAL SYSTEM

The electrical system is well protected with fuses. Pre-wired for extra equipment.

**Central warning:** Central warning lamp for following functions: engine oil pressure, brake pressure, parking brake, engine temperature, transmission temperature, transmission oil pressure.

Voltage	V		24
Batteries	No. / V		2 / 12
Battery capacity ea.	Ah		140
Cranking capacity ea.	A		800
Reserve capacity ea.	min		270
Alternator rating	W / A		1540 / 55
Starter motor output	kW	hp	6,6 9



## SERVICE REFILL CAPACITIES

Crankcase	dm <sup>3</sup> , l	US gal	29	7,7
Fuel tank	dm <sup>3</sup> , l	US gal	340	89,8
Cooling system	dm <sup>3</sup> , l	US gal	70	18,5
Transmission, total	dm <sup>3</sup> , l	US gal	47	12,4
Front axle, total	dm <sup>3</sup> , l	US gal	39	10,3
Rear axle, total	dm <sup>3</sup> , l	US gal	49	12,9
Hydraulic system	dm <sup>3</sup> , l	US gal	320	84,5
Hydraulic tank	dm <sup>3</sup> , l	US gal	230	60,8



## DRIVETRAIN

**Torque converter:** single-stage, single-phase.

**Transmission:** Volvo BM power shift transmission of countershaft type with directional clutch modulation. Three speeds forward and three reverse. Single lever control. Compaction will normally be done operating in 1:st or 2:nd gear at average speeds 7-8 km/h - 4 to 5 mph. Machine travel speeds are theoretical and based on a rolling resistance of 4%. Travel speeds will vary depending on ground conditions and type of compactor wheels.

**Axles:** fully floating half-shafts with planetary type hub reduction gears. One-piece axle housing of ductile iron. Rigid front axle and oscillating rear axle.

**Differential:** 100% differential lock on front axle. Engagement and disengagement by means of switch on cab floor. Gearing is conventional, hypoid gears.

**Hub reduction:** Volvo BM manufacture with low-friction roller bearings on each planetary gear. The hub reduction gears can be removed without having to remove wheels and brakes.

Torque multiplication				2,69 : 1
Transmission, make				Volvo BM
Model				HT 200
Running speeds				
1, forward/reverse	km/h	mph	7,1	4,4
2, forward/reverse	km/h	mph	13,2	8,2
3, forward/reverse	km/h	mph	25,2	15,7
Front axle, make				Volvo BM
Model				AH 70 A
Rear axle, make				Volvo BM
Model				AH 70 D
Oscillation movement, total	± °		15	
Vertical wheel travel	mm	in	600	23,5

## WHEELS

Chopper wheels, Order No				91058
Drum width	mm	ft in	850	2'9"
Drum diameter	mm	ft in	1400	4'7"
Pad height	mm	ft in	168	6,6"
Number of pads			24	
Chopper wheels, Order No				90034
Drum width	mm	ft in	750	2'6"
Drum diameter	mm	ft in	1400	4'7"
Pad height	mm	ft in	168	6,6"
Number of pads			20	
Trapezoidal pads, Order No				91062
Drum width	mm	ft in	850	2'9"
Drum diameter	mm	ft in	1400	4'7"
Pad height	mm	ft in	135	5,3"
Number of pads			48	
Cleaners, Order No				91061
Trapezoidal pads, Order No				90035
Drum width	mm	ft in	750	2'6"
Drum diameter	mm	ft in	1400	4'7"
Pad height	mm	ft in	135	5,3"
Number of pads			48	
Cleaners, Order No				99319



## BRAKE SYSTEM

The brake system meets requirements according to SAE J 1152, EG 71/320 and ISO 3450.

**Service brakes:** air-hydraulically operated power disc brakes. Transmission disengagement when braking pre-selected with a switch on the instrument panel.

**Secondary system:** dual-circuit system, divided between axles. The central warning light flashes for low system pressure in any circuit and the monitoring light for the circuit with inadequate pressure comes on.

**Parking brake:** enclosed wet multi-disc brake built into transmission. A spring-loaded application. Hydraulic release with a control on left of operator. A warning lamp indicates when the parking brake is applied and ignition is turned on. The central warning light flashes when gear lever is in forward or reverse while the parking brake is engaged.

Brake friction area				
front/wheel ea.	cm <sup>2</sup>	in <sup>2</sup>	810	126
rear/wheel ea.	cm <sup>2</sup>	in <sup>2</sup>	810	126
Reservoirs	No.		3	
volume, total	dm <sup>3</sup> , l	in <sup>3</sup>	47,1	2870
Parking brake area, total	cm <sup>2</sup>	in <sup>2</sup>	1547	240



## STEERING SYSTEM

Articulated steering. Orbitrol steering with boosted flow.

**Pump:** double vane fitted to a power take-off on transmission.

**System supply:** steering system supplied from front section of pump.

**Cylinders:** two double-acting cylinders with chromed piston rods.

Steering cylinders, number			2	
Bore	mm	in	110	4,3
Piston rod diameter	mm	in	50	2
Stroke	mm	in	423	16,7
Working pressure	MPa	psi	15	2175
Flow volume	dm <sup>3</sup> , l/min		190	
	US gal/min			50
at	MPa	psi	10	1450
and engine speed	rps	rpm	36,7	2200



## CAB

Tested and approved as safety cab according to the Swedish Working Environment Act section 3, sub-section 8, and meets standards according to ISO 3471-1980, ROPS (SAE J1040C), ISO 3449-1980 FOPS (SAE J231), SS/ISO 6055 "Overhead guards for fork lift trucks" and SAE J386 Operator Restraint System.

The cab is mounted on four rubber pads and is well insulated. The windshield is of laminated safety glass, all other windows being of tempered safety glass.

**Heater and defroster:** heating element with filtered fresh air and 3-speed fan with defroster outlets for all windows.

**Operator's seat:** spring suspended, fully adjustable operator's seat with seat belt and heater.

Emergency exits			3	
Ventilation	m <sup>3</sup> /min	cfm	10	353
Heating capacity	kW	BTU/h	11,6	39600
Operator's seat				ISRI 6000 / 575



## HYDRAULIC SYSTEM

Open center system pilot operated, and filtered breather on reservoir.

**Pump:** double vane pump fitted to a power take-off on transmission.

**System supply:** system supplied from rear section of pump.

**Valve:** double-acting 3 section valve. The control valve is governed by a 3-section servo valve.

**Lifting function:** the valve has four positions: lifting, neutral, lowering and floating. Disengageable electro-magnetic boom kick-out and ground positioner. Adjustable for all positions between maximum reach and full lifting height as well as ground position.

**Tilting function:** the valve has three positions: rollback, neutral and forward tilting. Disengageable electro-magnetic bucket positioner adjustable for all desired loading angles.

**Cylinders:** double-acting. Boom-tilt cylinders are slightly shorter than the standard L160 loader cylinders for improved protection. Dump height is also reduced from the standard L160 loader.

**Filter:** full-flow filtering through 10 micron filter cartridge in combination with magnetic core.

**Oil cooler:** as standard.

**Load unit:** hydraulic cylinders fitted in line with lifting arms.

Working pressure	MPa	psi	17,0	2465
Flow volume	dm <sup>3</sup> , l/min		380	
	US gal/min			100,4
at	MPa	psi	10	1450
and engine speed	rps	rpm	36,7	2200
Lifting cylinder, number			2	
Bore	mm	in	170	6,7
Piston rod diameter	mm	in	80	3,1
Stroke	mm	in	892	35,1
Tilting cylinder, number			2	
Bore	mm	in	140	5,5
Piston rod diameter	mm	in	70	2,8
Stroke	mm	in	983	38,7
Lifting time (with load, SAE)	s			6,3
Tipping time (with load, SAE)	s			4
Lowering time (empty)	s			3,2
Total cycle time	s			13,5

## DIMENSIONAL DATA

Where applicable specifications and dimensions are in accordance with SAE Standard J 732c, 742 b and J 818 b. The information concerns a machine equipped with chopper wheels (width 850 mm - 33,5").

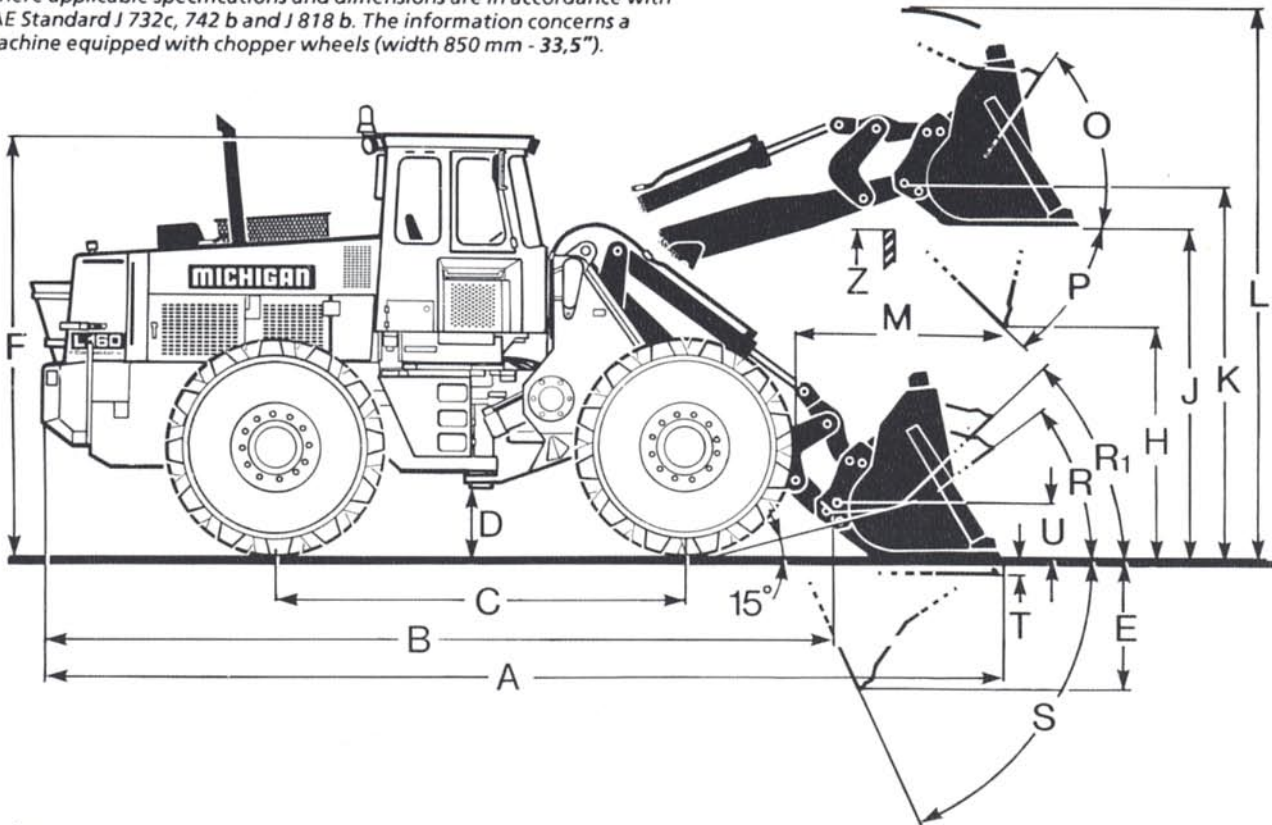

### Bucket type

Both buckets are fitted with a high mesh refuse spillguard.

- 1 = General purpose bucket with teeth
- 2 = Multi-purpose bucket without teeth
- D = Pin-On

Order No.		91032		1805067 <sup>⊗</sup>	
Mounting / Bucket type		D/1		D/2	
Volume, heaped	m <sup>3</sup> yd <sup>3</sup>	4.0	5.2	3.4	4.5
Breakout force	kN lbf	145,7	32740	151,2	33970
A	mm ft in	8320	27'3"	8090	26'6"
B	mm ft in	6670	21'11"	6670	21'11"
C	mm ft in	3550	11'8"	3550	11'8"
D	mm ft in	540	1'9"	540	1'9"
E	mm ft in	1210	4'0"	1210	4'0"
F*	mm ft in	3570	11'9"	3570	11'9"
H	mm ft in	1770	5'10"	1960	6'5"
J	mm ft in	2930	9'8"	2910	9'7"
K	mm ft in	3220	10'7"	3220	10'7"
L	mm ft in	5390	17'8"	5270	17'3"
M	mm ft in	1910	6'3"	1880	6'2"
O	°	51		51	
P	°	45		45	
R	°	40		40	
R <sub>1</sub> **	°	44		44	
S	°	67		67	
T	mm ft in	20	0.7"	40	1.7"
U	mm ft in	460	1'6"	460	1'6"
V	mm ft in	3400	11'2"	3440	11'3"
X	mm ft in	2430	8'0"	2430	8'0"
Y	mm ft in	3280	10'9"	3280	10'9"
Z	mm ft in	2830	9'3"	2830	9'3"
a <sub>1</sub> clearance circle over bucket	mm ft in	7560	24'9"	7500	24'7"
a <sub>2</sub>	mm ft in	6950	22'9"	6950	22'9"
a <sub>3</sub>	mm ft in	3670	12'1"	3670	12'1"
a <sub>4</sub>	±°	37		37	
Weight distribution					
front	kg lb	13280	29280	12980	28620
rear	kg lb	14030	30930	14230	31370
Operating weight	kg lb	27310	60210	27210	59990

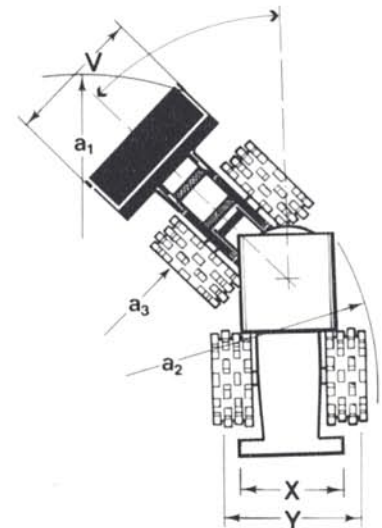

\* Add 170 mm 6.7 in for removable raincap

\*\* Carrying position SAE

⊗ Also available with bolt on teeth

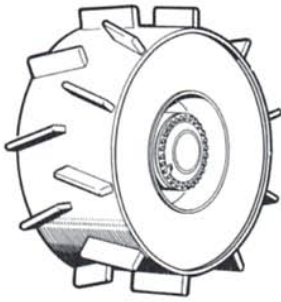

**Chopper wheel**



**Trapezoidal pads**

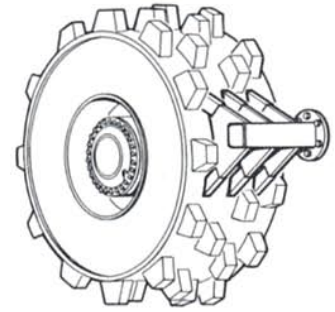

**Cleaners for trapezoidal pads**

GROUND PRESSURE		General purpose bucket				Multi-purpose bucket			
		Chopper wheels		Trapezoidal wheels and cleaners		Chopper wheels		Trapezoidal wheels and cleaners	
Drum width	mm	750	850	750	850	750	850	750	850
	in	29,5	33,5	29,5	33,5	29,5	33,5	29,5	33,5
Ground pressure Front *	kp/cm <sup>2</sup>	1,18	1,08	1,22	1,10	1,15	1,06	1,19	1,07
	psi	16,8	15,4	17,4	15,6	16,4	15,1	16,9	15,2
Rear *	kp/cm <sup>2</sup>	1,25	1,14	1,29	1,16	1,27	1,16	1,32	1,17
	psi	17,8	16,2	18,3	16,5	18,1	16,5	18,8	16,6
Pounds per linear inch	PLI	489	449	506	454	487	448	504	452

\* Wheels sinking into surface. A = 100 mm 4"

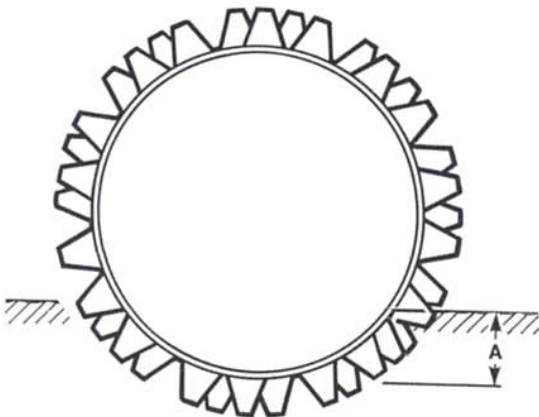

The Michigan method of calculating the ground pressure of a compactor in this case involves deducing the projected wheel drum area against the ground at various depths of penetration into the surface, and relating the result to the axle loading of that wheel.

ALTERATION OF DIMENSIONAL DATA		Chopper wheels		Trapezoidal wheels and cleaners			
		750 mm - 29,5"		750 mm - 29,5"		850 mm - 33,5"	
Width over wheels	mm in	-200	-7,9	-200	-7,9	-	-
Ground clearance	mm in	-	-	-35	-1,4	-35	-1,4
Operating weight	kg lb	-1120	-2470	-220	-485	300	660

## STANDARD EQUIPMENT

ALTERNATOR, 55 A  
AIR CONDITIONER (19 400 BTU/hr)  
BATTERY DISCONNECT, LOCKABLE  
BOOM KICKOUT, AUTOMATIC, ADJUSTABLE  
BRAKES, SERVICE, 4-WHEEL AIR OVER  
HYDRAULIC, DRY DISC, TWO CIRCUIT  
BRAKE SYSTEM, SECONDARY  
BUCKET LEVELER, AUTOMATIC WITH  
POSITION INDICATOR  
CAB ACCESS STEPS & HANDRAILS (SAE J185)  
CAB, ROPS (SAE J 1040) (ISO 3471)  
FOPS (SAE J231) (ISO 3449)  
Acoustical Lining  
Ash Tray, cigar lighter  
Door, lockable (left side access)  
Electrical System: (24 V): prewired for  
optional accessories  
Environmental Control:  
Heater/defroster/pressurizer  
(39 600 BTU/hr) with three-speed blower  
fan, filtered air  
Floor Mat  
Hand Throttle  
Interior Light  
Interior Rearview Mirror  
Safety Glass, tinted  
Seat Belt  
Seat, suspension, 6-way adjustable, heated  
Steering Wheel, adjustable tilt  
Storage Compartment  
Sun Visor  
Windshield Washer & Wiper, front & rear  
Intermittent Wiper  
DIFFERENTIALS:  
Front: Air operated differential lock  
Rear: Conventional  
DRAWBAR WITH PIN

FAN, suction type  
ENGINE COOLANT FILTER  
HOOD SIDE PANELS  
HYDRAULIC CONTROL LEVER SAFETY LATCH  
HYDRAULIC PRESSURE TEST PORTS,  
QUICK CONNECT  
HYDRAULIC OIL COOLER  
INSTRUMENTS/GAUGES, ILLUMINATED:  
Brake System, Pressure (Dual Indicator)  
Engine Coolant Temperature Gauge  
Fuel Gauge  
Hourmeter  
Transmission/Converter Fluid  
Temperature Gauge  
ISOLATION MOUNTS:  
Cab, Engine, Transmission  
LIFTING LUGS  
LIGHTS:  
Attachment Lights  
Beacon, Rotating Amber  
Driving (2-front), Halogen  
Parking Lights, Side Marker Lights  
Stop/Tail Combination (2-rear)  
Turn Signals with Hazard Warning Switch  
Work Lights: Halogen (4-Front, 4-Rear)  
MIRRORS, REARVIEW (2), EXTERIOR  
NEUTRAL START FEATURE  
PRECLEANER, ASPIRATED AIR  
CLEANER/MUFFLER SYSTEM  
PROTECTION GUARDS, Working Light Rear  
RAIN CAP  
SIGHT GLASSES:  
Coolant Level  
Hydraulic Fluid Level  
STARTING AIDS:  
Pre Heating Coil  
Engine Fuel Mixture Enrichment

STEERING FRAME LOCK  
TRANSMISSION, POWER SHIFT  
MODULATED WITH:  
Single Lever Control and Operator  
Controlled Declutch  
UNDERBODY AND SIDEPROTECTION GUARDS  
VALVE, MAIN HYDRAULIC:  
Three (3) Spool, with Pilot Valve  
VANDALISM LOCK, PROVISION FOR:  
Batteries  
Engine Coolant  
Engine Oil  
Fuel  
Hydraulic Fluid  
Converter/Transmission Fluid  
WARNING ALARMS:  
Horn, Electric  
Reverse Alarm (SAE J994)  
WARNING & MONITORING LIGHTS:  
Air cleaner Restriction  
Alternator Malfunction  
Central Warning Lamp:  
Brake System Pressure  
Engine Coolant Temperature  
Engine Oil Pressure  
Parking Brake Applied (Transmission in  
gear)  
Transmission Fluid Temperature  
Differential Lock  
Engine Intake Manifold Preheater  
High Beam Driving Lights  
Parking Brake Applied  
Transmission Clutch Pressure  
WATER SEPARATOR

## OPTIONAL EQUIPMENT

Bucket Related Options  
Cutting Edge, Reversible, Bolt-on for all  
Straight Edge, Predrilled Buckets  
Teeth, Bolt-on, for Straight Edge Buckets  
only, cannot be used with Light Material  
Buckets  
Compactor Related Options  
Chopper Wheels  
Trapezoidal Wheels  
Cleaners for Trapezoidal Wheels

Dual Service Brake Pedals  
Engine Block Heater (110 V)  
Engine Oil Pressure Gauge  
Horn, Air, Electrically Operated  
Hydraulic Attachment Bracket  
Hydraulic Control Third

Hydraulic Control 4th & 5th  
Hydraulic Control Return Line  
Radio Panel  
Voltmeter  
Wheel Nut Wrench

Under our policy of continuous product improvement, we reserve the right to change specifications and design without prior notice. The illustrations do not necessarily show the standard version of the machine.

## VME Americas Inc.

23001 Euclid Avenue  
Box 178017  
Cleveland, Ohio 44117-8017

A subsidiary of VME Group N.V.



L160 Co 1/87

22 1 669 1818