

MICHIGAN

LOADERS: MODELS L320, L480, L480T



VOLVO BM
MICHIGAN
EUCLID

FOR OVER 30 YEARS WE'VE BEEN BUILDING OUR REPUTATION IN A BIG WAY.

THEY DON'T GET ANY TOUGHER, ANY STRONGER,
THAN THESE MICHIGAN HEAVY-DUTY LOADERS.

From the cutting edge to draw bar pin, these powerful Michigan loaders have been designed to be primary production loaders.

We've built them with all the knowledge and real world experience we've gained over the past three decades.

The result – heavy-duty loaders that are true high volume producers, that can work 3 shifts a day, 7 days a week,

month after month, with only normal preventative maintenance.

For the most demanding jobs on the face of the earth – load and carry, truck and hauler loading, stockpiling and feeding hoppers, crushing and screening plants, in shot rock and over burden removal, chopping or breaking out coal seams – Michigan loaders get the job done.



HIGH PERFORMANCE LOADERS.

Michigan's hydraulic systems, buckets and booms, environmental cabs, drivetrains, engines, brakes and service features are

among the best there are today.

The result: smooth operation, a steady flow of productivity.

L320 8yd³ – 9yd³ (6,1m³ – 6,9m³)

It's been called the smoothest loader on earth. It will load 35-ton haulers in just three passes; charge crushers and hoppers; handle shot rock quickly. A long boom option is available.



L480 12.5yd³ (9,6m³)

12.5 cubic yards (9,6m³) of loading performance, straight edge or spade nose. Dependable, durable, productive, the L480 effectively loads haulers up to 100 tons payload.



L480T 12.5yd³ (9,6m³)

This is *the* high performance loader. The L480T features a Turbo transmission – an advanced power transmission system that gives the L480T high acceleration that results in fast work cycles.



WE'RE BIG ON FEATURES FROM THE INSIDE OUT.

FEATURES THAT MAKE THESE MICHIGAN LOADERS HARD WORKING PRODUCTION LOADERS.

This view of the L480 will show you just some of its performance engineered components. The true measure of a loader is the cost per ton

of material moved. All the features of the L480 work together to give you a high return on your loader investment.

***12-cylinder, 4-cycle,
turbo-charged and aftercooled
Cummins diesel engine.***



***Hydraulically-actuated dry disc
brakes on all four wheels.***

All pins sealed for extended lube intervals.

Constant mesh power shift transmission.

Environmentally-controlled cab designed for operator comfort, good visibility and easy access with pilot-operated, hydraulic controls and conveniently located pedals and switches.

Heavy-duty boom and responsive, powerful Z-bar linkage designed for bucket loading efficiency.

Double plate lift arms provide in-line mounting of cylinders, bellcranks and pushrods resulting in balanced loading on the pins and bushings.



Special application buckets available for your job site requirements.

Lift arms, buckets, pushrods and bellcranks designed for optimum breakout, bucket loadability and load retention.

Outboard-mounted needle-bearing planetaries for maximum efficiency.

Limited-slip differentials, front and rear, delivers more torque to the wheel with the best available traction, assuring maximum traction under adverse conditions.

VME HYDRAULICS: MUSCLE IN MOTION.

WE'VE BROUGHT TOGETHER ALL THE LATEST ADVANCES IN HYDRAULICS.

Our hydraulics are setting performance standards for the industry. Michigan loader hydraulic systems make the most efficient use of horsepower. Our systems run cool for improved component life. In addition, our hydraulics assist rimpull when bank digging, provide smooth, positive steering and help increase fuel savings.

Michigan loaders may be large, but they work with ease and precision. An experienced operator handling a Michigan heavy-duty loader is beautiful to watch. What you see is a smooth flow of productivity.

Separate hydraulic oil cooler for long component life.

Finger-tip hydraulics make all the difference.

Lift and tilt levers are ergonomically mounted to the right-hand side of the adjustable suspension seat. This new control system greatly reduces operator effort and increases productivity. In addition, the operator has an excellent feel of the bucket, resulting in efficient placement of materials in hoppers and haulers.

Sight gauges for operator convenience.

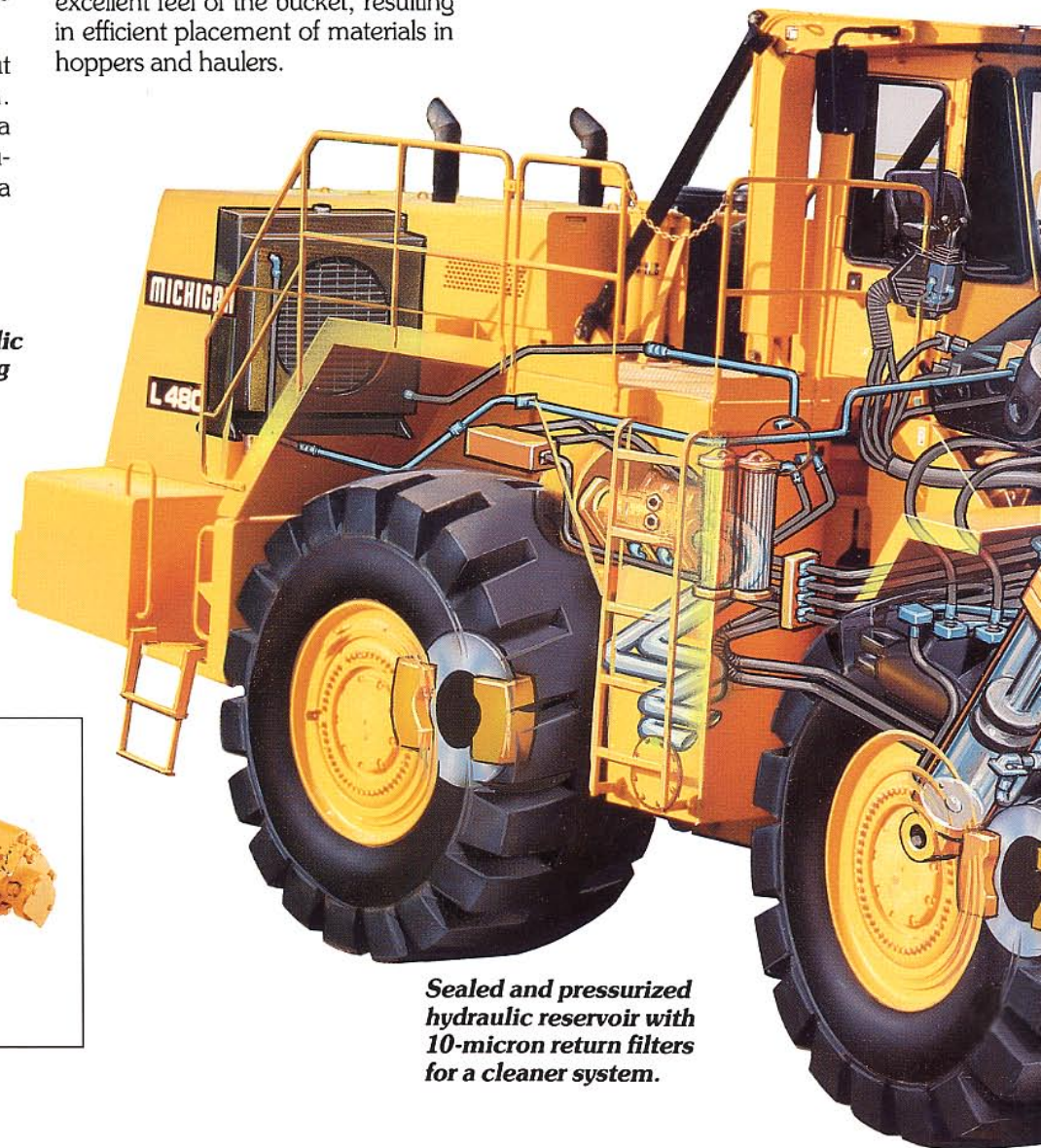

Sealed and pressurized hydraulic reservoir with 10-micron return filters for a cleaner system.

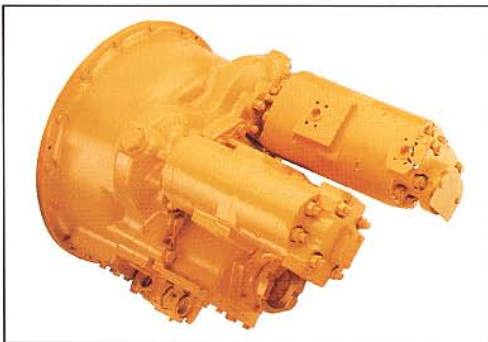



The L480T hydraulic system.

Because of the faster ground operating speeds, we increased the hydraulic raising and lowering times, resulting in faster work cycles. For example, the pumps are larger than the L480 pumps, delivering more than 12% greater flow to the main system.

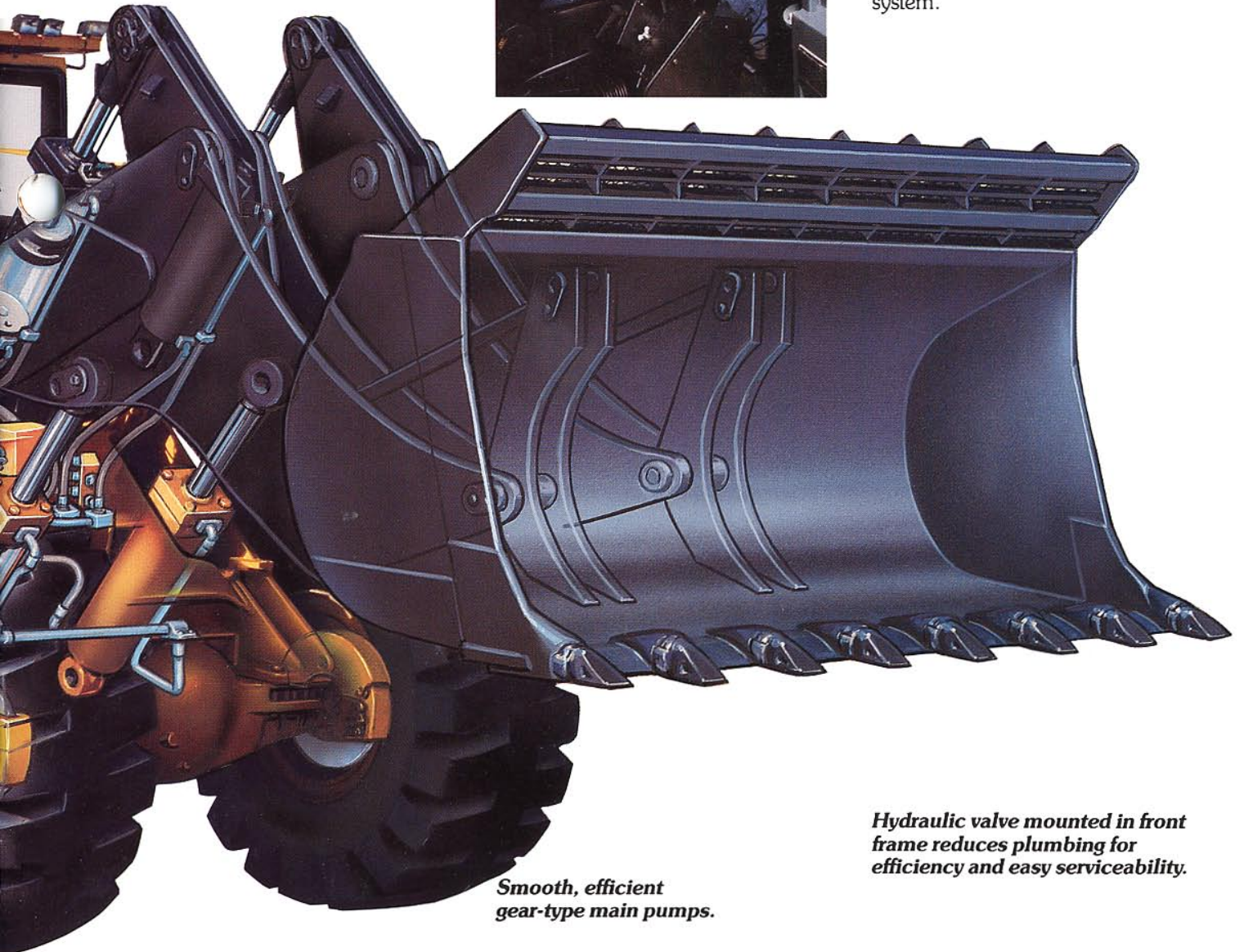

Smooth, efficient gear-type main pumps.

Hydraulic valve mounted in front frame reduces plumbing for efficiency and easy serviceability.

L320: FROM OVER BURDEN TO SHOT ROCK TO FINISHED MATERIALS, IT'S ALL IN A DAYS WORK.

THE HEIGHT AND REACH TO LOAD 50-TON HAULERS IN FOUR PASSES.

The L320 belongs at the face. With its high breakout force coupled with excellent crowding power for optimum digging performance, the L320 is right for the quarry.

With a full 12-ton capacity, the L320 has been engineered to match with a 35-ton hauler. It can fill the 35-ton hauler in just three passes, a 50-ton hauler in just four passes.

The L320 is available with a standard boom or an optional long boom for jobs that require extra dump height and reach. Both booms provide excellent machine stability and load-carrying ability to match demanding job conditions.



L320'S RUGGED DESIGN MAKES IT A DEDICATED PRODUCTION MACHINE.

The nimble L320 can settle in and be a great material handling loader. This Michigan loader is right at home with finished or processed materials. Load-and-carry, feeding hoppers, stockpiling, and log handling. They are all in a day's work for the L320.

The L320's tapered roller bearings in the upper and lower articulation hinges, as well as the bucket to boom pivot are sealed and require no lubrication. This means longer life for the bearings and more productive up-time.

Whether you're looking for extreme versatility or heavy-duty production, the Michigan L320 is the machine for your job.



L320 POWER AND EFFICIENCY – THAT’S THE SECRET OF OUR LOADER DESIGN.

A well coordinated drivetrain.

A job proven KTA-19C Cummins engine rated at 452 gross horsepower (337 kW) powers the Michigan L320. A Clark 8000 series torque converter maximizes machine performance. The Clark 6000 series transmission is a modulated countershaft design, with four speeds forward and reverse. Speeds range from 4 to 21 mph.

The power-saving hydraulic system provides efficient use of horsepower, powerful lifting and easy steering. The system is also balanced with the engine and transmission, resulting in low fuel consumption and maximum engine power for increased traction.

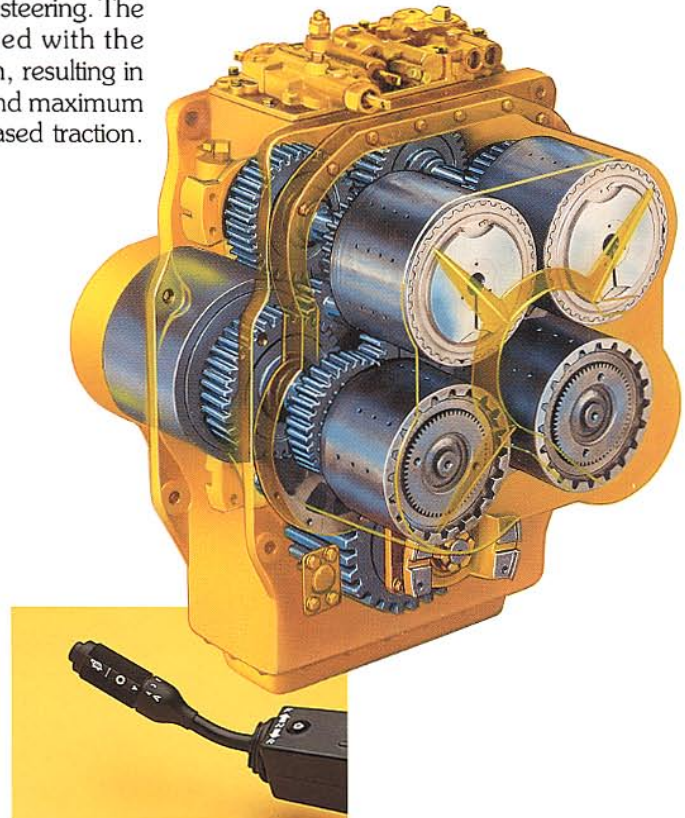
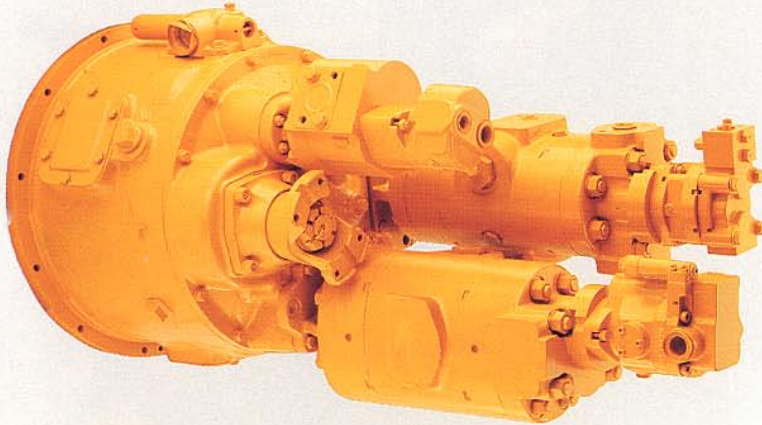

Limited-slip differentials for improved traction.

Limited-slip differentials are standard equipment in both L320 axles. They automatically transfer driving torque to the wheel with the best traction. They provide maximum wheel power under varying conditions, while minimizing tire slippage and wear.

Limited-slip differentials do not affect the operator's steering. The single lever transmission control gives the operator full control of direction and speed. Direction is changed by shifting the lever forward and back. Speed shifts are achieved by rotating the handle.

brakes. A separate cooling system provides the brakes with cooled and filtered oil. Brakes meet SAE J1473 and ISO 3450 requirements. Secondary braking capability is provided by a dual-circuit system split axle by axle. Dead-engine braking is provided by two nitrogen-charged accumulators.

Oil-cooled, hydraulic disc brakes.

The hydraulic brakes are outboard-mounted, liquid cooled, wet disc

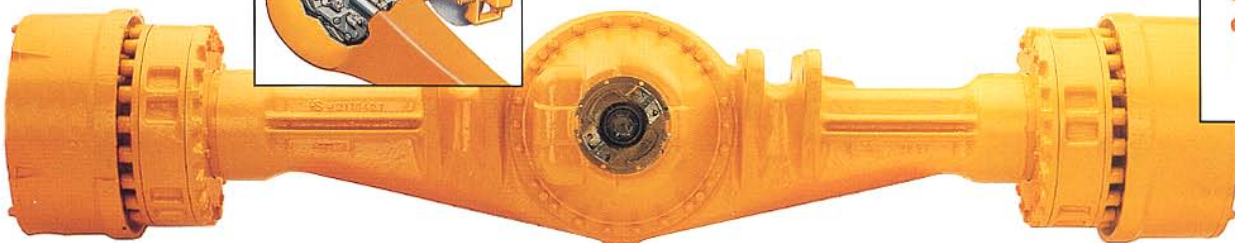
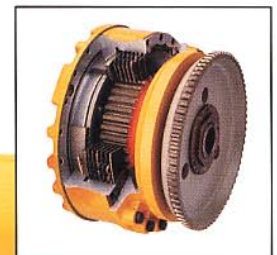
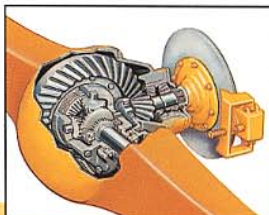

HEAVY-DUTY CAPACITY FROM CUTTING EDGE TO COUNTERWEIGHT.

Structural integrity built-in for the most rugged conditions.

The structural design of the L320 uses high-strength plate steel for the main frame and boom. The side plates of the frame are 1.25 (3,18cm) inches thick.

The bucket to boom hinge pins are permanently sealed with tapered roller bearings. This retains lube and protects against dirt for longer service life. The axle assemblies are pinned to the front frame and rear axle cradle assembly. The frame articulation hinge joint is designed

to withstand high loads. The upper and lower tapered roller bearings are widely spaced, sealed and packed at assembly.

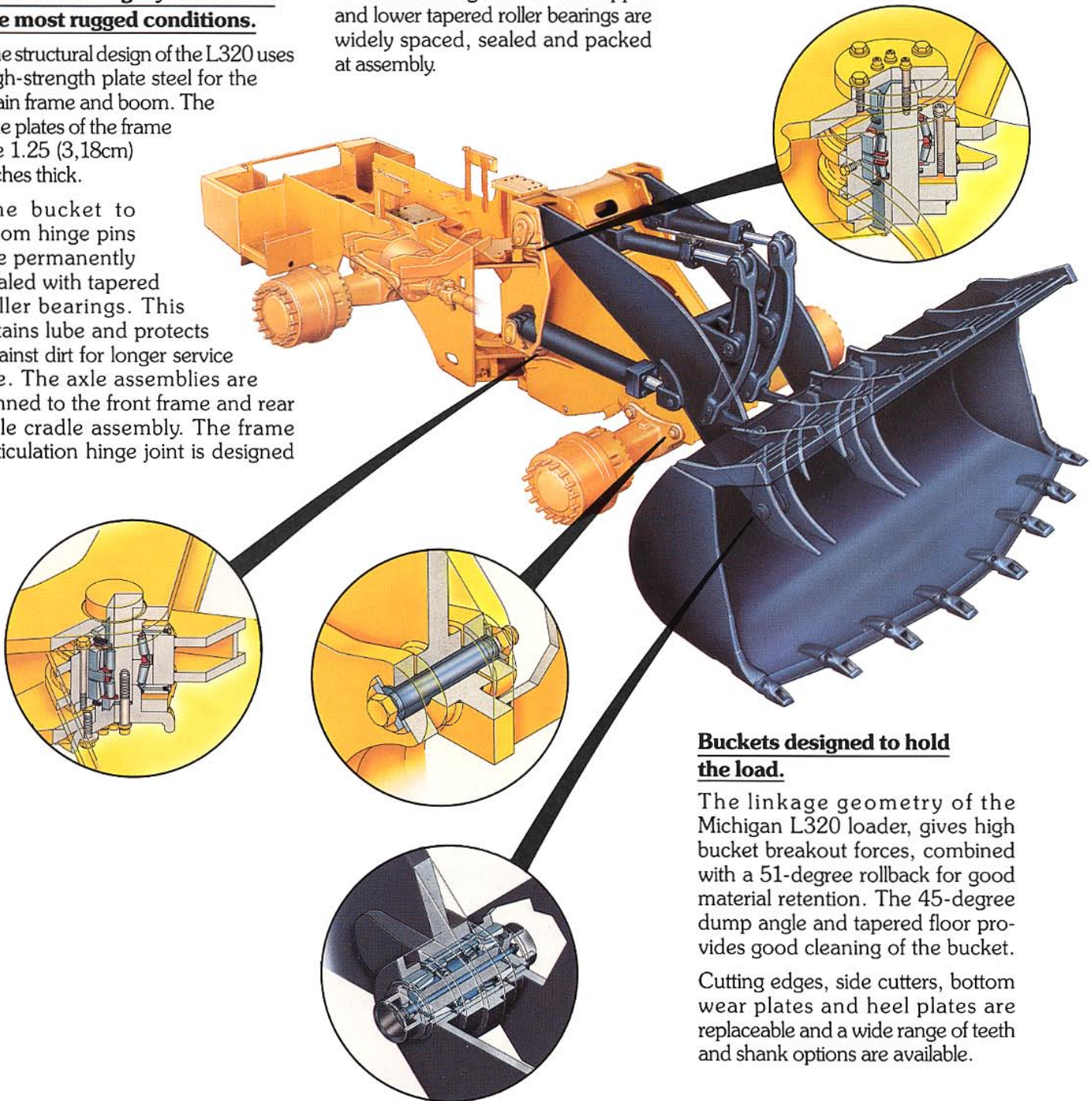

Buckets designed to hold the load.

The linkage geometry of the Michigan L320 loader, gives high bucket breakout forces, combined with a 51-degree rollback for good material retention. The 45-degree dump angle and tapered floor provides good cleaning of the bucket.

Cutting edges, side cutters, bottom wear plates and heel plates are replaceable and a wide range of teeth and shank options are available.

COMFORTABLE OPERATORS ARE PRODUCTIVE OPERATORS.

We know how important it is to give operators the best working environment possible. That's why we designed the Michigan loader cab with comfort, convenience and safety in mind.

Setting the standards of comfort for the industry, the Michigan cab provides filtered, pressurized air, circulating in a sound-insulated interior. Air conditioning, heating, and defrosting is standard, which allows work to continue regardless of weather conditions outside.

An adjustable, suspension-type seat reduces fatigue, keeps the operator comfortable, and helps maintain high productivity.

At the operator's fingertips are boom and bucket levers, steering wheel, shift lever, and a carefully laid out instrument panel with easily-understood instrumentation.

The full-length doors with the flat floor make walking in and out easy. Large, tinted, safety glass windows provide excellent visibility and protection. The exterior mounted ROPS/FOPS provides good visibility and low operator compartment sound levels.

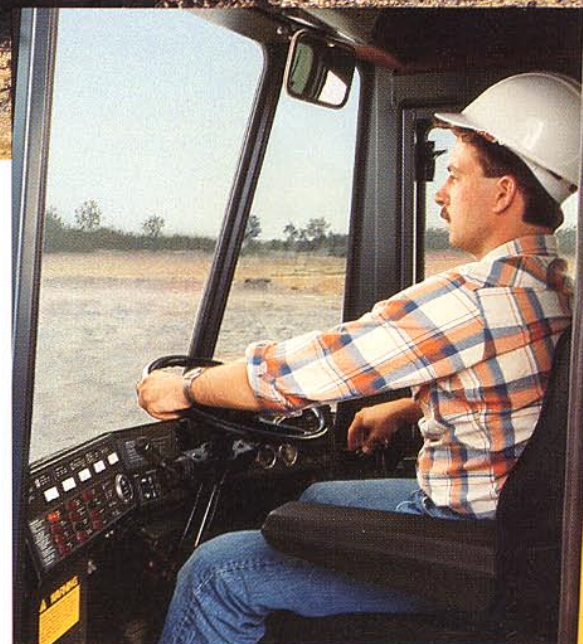
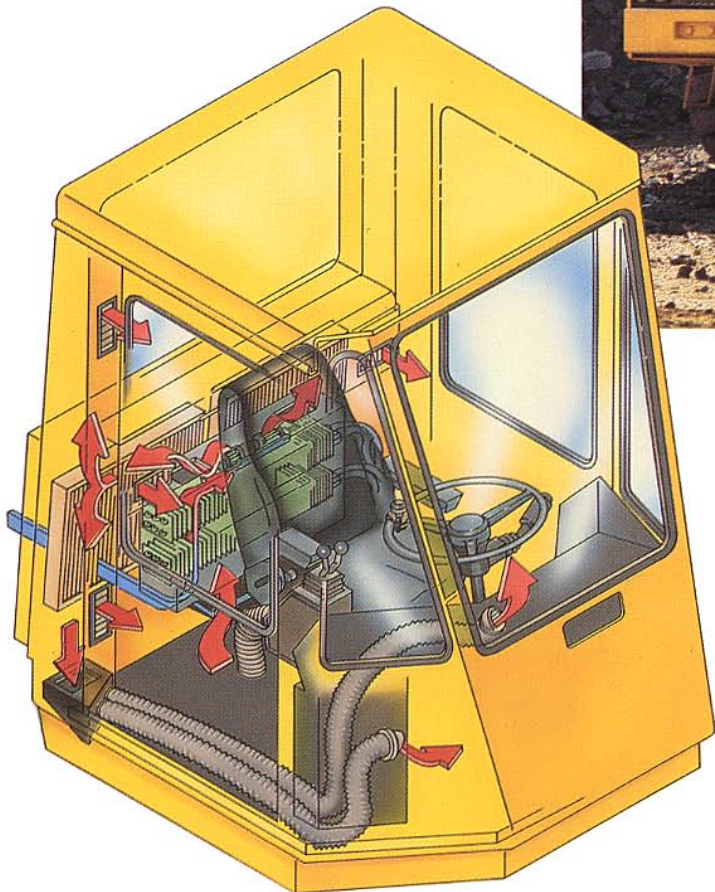

L480

DAY-IN, DAY-OUT MAXIMUM TONNAGE AT THE RIGHT COST PER TON.

IT'S WHAT HIGH PERFORMANCE IS ALL ABOUT.

Whether loading haulers or feeding a crusher, the L480 has been built for heavy-duty, large-capacity applications.

This highly dependable, durable, productive machine has a 12.5yd³ (9,6m³) bucket. Steering is easy and responsive. Boom and bucket

hydraulics provide the most efficient crowding and digging balance possible.

Limited-slip differentials in both axles are an exclusive Michigan loader feature.

The L480 matches up well with the most common hauler sizes: 2 passes to fill a 35-ton hauler, 3 passes to fill a 50, 5 to fill an 85 and 6 to fill a 100-tonner.



Heavy-duty structural integrity.

Side plate steel in the front frame is low alloy 42,000 psi minimum yield strength. The front axles mount to the frame with 1.5-inch (3,81cm) diameter bolts.

Lift arms, buckets, pushrods and bellcranks have been designed for optimum breakout, bucket loadability and load retention.

From the ground up, the L480 is a producer.





L480

MORE MUSCLE BY DESIGN.

Powerful lift arms.

The L480's double plate lift arms are made from 1.75-inch (4,45cm) thick, 50,000 psi yield strength steel. Four massive one-inch (2,5cm) thick plates are located inside and outside the front frame to give a solid foundation for the base pivot pins and lift cylinder pins.

The double plate lift arms provide in-line mounting of cylinders and pushrods. This means balanced loading on the pins and good cylinder protection.

The operator has good visibility down through the front of the boom. Placement of the cross-tube near the bucket assembly adds to the strength of the boom assembly and allows the operator a good view of the work area.

The right combination.

The L480's lift-arm system offers an effective combination of lift and breakout forces along with good bucket angles throughout the lift cycle.

The adjustable automatic boom-raise kickout and bucket positioner are standard. The boom raise kickout can be adjusted to any position between the horizontal and full height.

The bucket positioner returns the bucket to the selected digging position while the lift arms are being lowered.

Both devices increase production by allowing the operator to give his full attention to positioning the machine at the bank or dump.

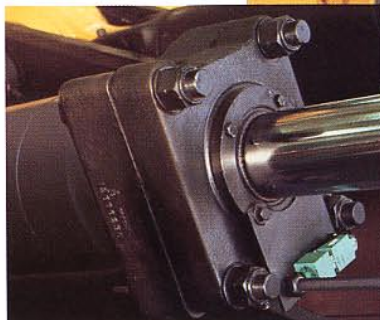

Buckets with bite.

12.5 cubic yard (9,6 m³) buckets are available in either straight-edge or spade-nose configurations, depending on application requirements.

Both have heavy-duty, reinforced spillguards. Replaceable, bottom wear plates minimize drag resistance and extend bucket life. A wide variety of teeth and cutting edge caps are available.



19 TONS PER PASS.



Comfort is not an option. It's standard.

Ask an operator – Michigan loader cabs are comfortable work stations. There are two full-length doors, one on each side, for easy entry and exit. The floor is flat with no obstructions. Visibility is excellent through the tinted safety glass. There are windshield washers/wipers, front and rear.



The operator sits in a six-way adjustable suspension seat. Around him is a free-standing, wraparound dash panel. At his fingertips are the hydraulic controls that do the work. Foot pedals and power steering require minimal effort.

Michigan's limited-slip differential for more consistent driving torque.

The L480's exclusive limited-slip differentials are standard on both front and rear axles. They deliver more driving torque to the wheel with the best traction, producing maximum traction under varying conditions. In addition, the limited-slip differentials minimize wheel slippage and maintains easier steering.

The limited slip works automatically without any operator control required.

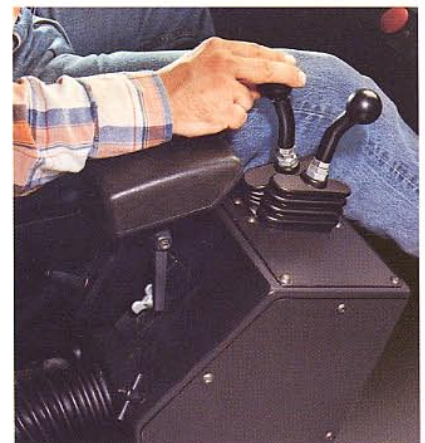

Naturally, there is a filtered, pressurized air system with heating and air conditioning to keep the operator warm in winter and cool in summer. With all these standard operator comforts, no wonder operators are setting new highs in productivity.

L480T TURBO TRANSMISSION FOR PRODUCTION POWER.

Only VME has the Turbo Transmission.

The Turbo transmission in the L480T gives the loader the capability of fast acceleration. The operator actuates the variable capacity torque converters to obtain the desired power and travel speeds.

Powerful hydraulics and fast, smooth directional shifts make the L480T both easy to operate and highly productive. That's why demanding loading situations are a specialty for the L480T.

The Turbo transmission is split-second quick.

Since there is only a fluid coupling between the engine and output gears, full power directional shifts can be made smoothly and easily for fast cycle times. That's why the L480T performs so much better than comparably-sized wheel loaders with conventional transmissions.

The Turbo transmission has no friction clutches to wear, adjust or replace. Shifting of either the speed range or direction is accomplished quickly and smoothly with no wear.

The simplicity and reliability of the Turbo transmission allows VME to offer, as standard, a 10,000-hour or 30-month warranty.

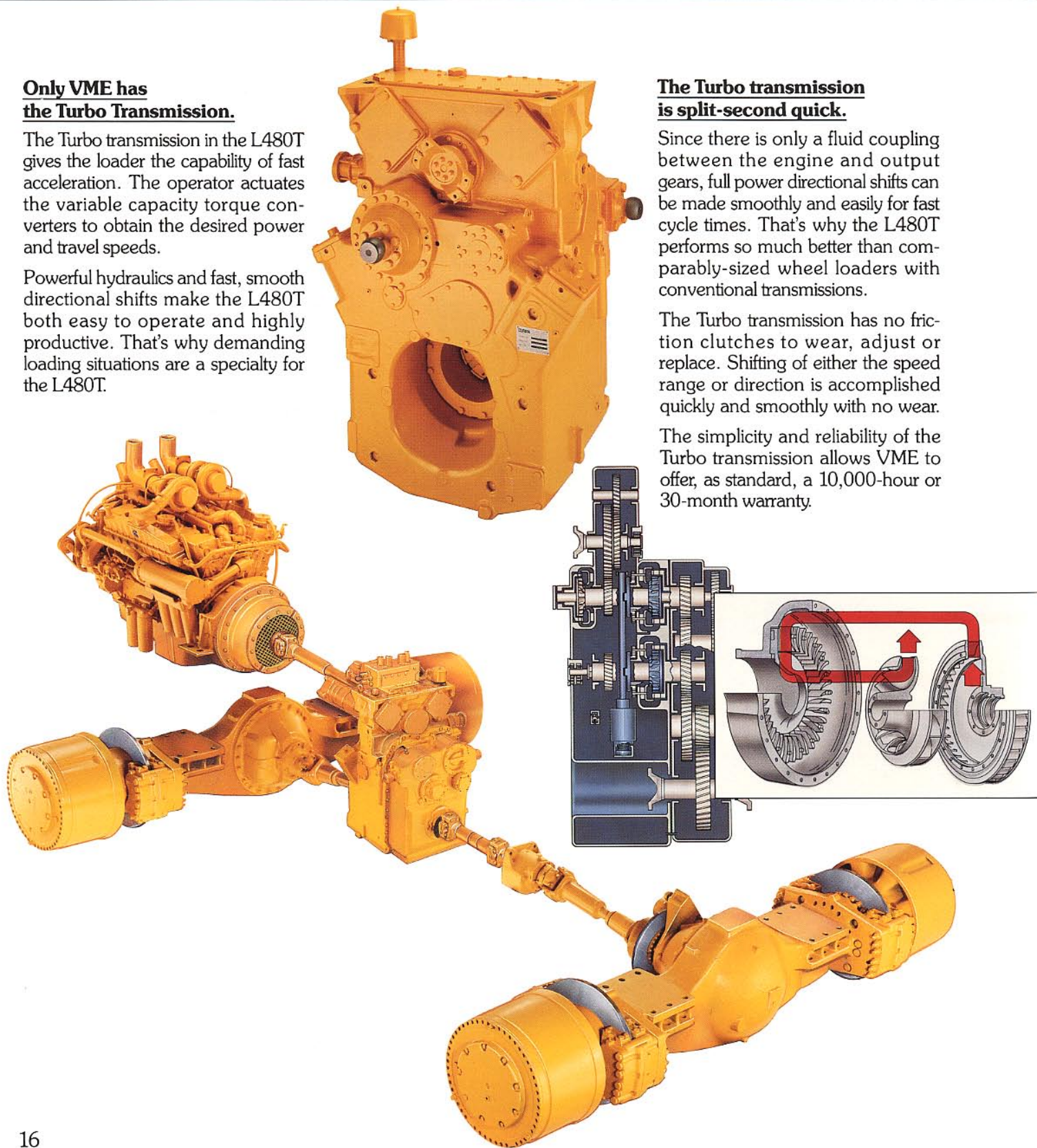

THE HIGHEST ACCELERATION. THE SHORTEST WORK CYCLES.



The most efficient travel / work range.

The Turbo transmission gives the operator complete control of the loader's speed and torque variations, and eliminates shifting except for directional changes. The transmission's converters, allow the operator to make directional shifts, allowing for the fastest possible work cycles.

In addition, the Turbo transmission provides good fuel economy, is quiet running and has longer component life.

All hydraulic dry disc brakes.

The L480T brakes are all hydraulic controlled, outboard-mounted dry disc brakes designed for long life. Power for the brakes is supplied by an independent brake pump. Each axle has its own hydraulic circuit and nitrogen-charged hydraulic accumulators to provide secondary braking to meet safety requirements for SAE J1473 and ISO 3450.

A monitor system in the cab alerts the operator to an applied parking brake or a front/rear system pressure malfunction. To prevent driving with the parking brake engaged, an interlock automatically applies the service brake if the transmission is engaged while the parking brake is applied.

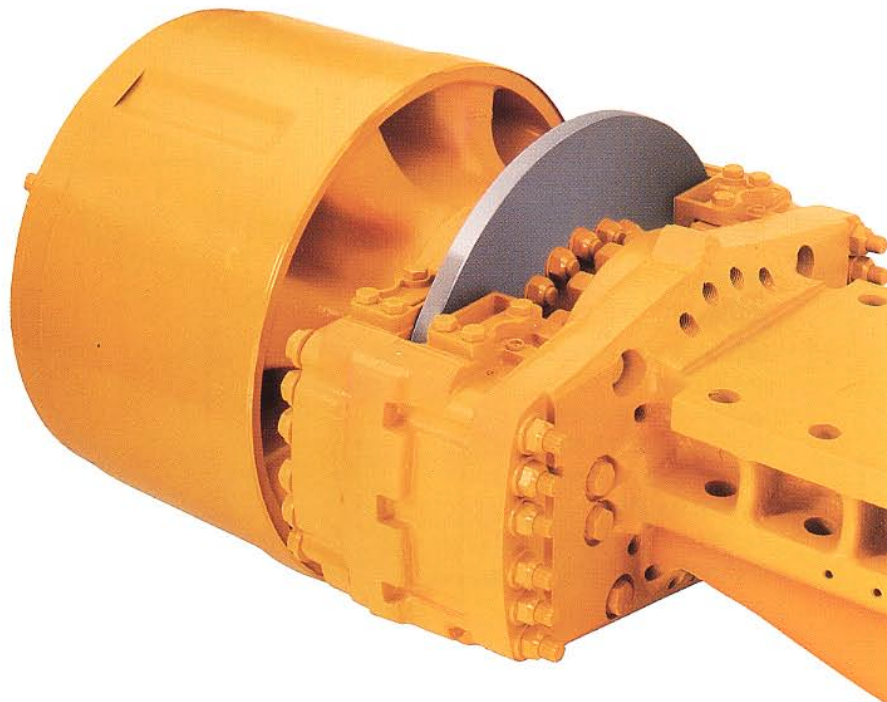

WE'VE MADE SERVICING SIMPLE.

If it's easy to service, it will be serviced.

The only way to make a loader easy to service is to think about serviceability right from the start, as the loader is being designed.

That's how we engineered our Michigan loaders.

We've thought about practical, convenient, labor and hassle-saving accessibility right from the start.

You save money on servicing time.

Our heavy-duty Michigan loaders are designed for daily and routine services to be done quickly and easily, standing on the ground or on a service platform of the loader. The cab-level service deck provides easy access to fuel tank filler, engine air cleaners, radiator expansion tank and filler and filters.

The center hinge area is wide, clean and uncluttered for easy service access to the transmission and steering cylinders, transmission sight gauge and hydraulic quick-connect pressure check ports. Access to the engine compartment is through wide upward-opening side panels.

When the customer talks, we listen.

Our technicians and engineers are in constant touch with the needs of the industry as well as with feedback from the field. This results in new improvements for added efficiency in service, maintenance and customer satisfaction.



Center hinge lube manifold.



Grease fittings grouped so they can be lubed from four ground level locations.



Battery box positioned for convenient inspection.

Visual sight gauge level checks provided for hydraulic and transmission fluid.





Air cleaner restriction sight gauge / service platform.



Quick-connect, remote pressure check ports save time and labor.



Engine oil level and fuel filters checked easily from service platform.

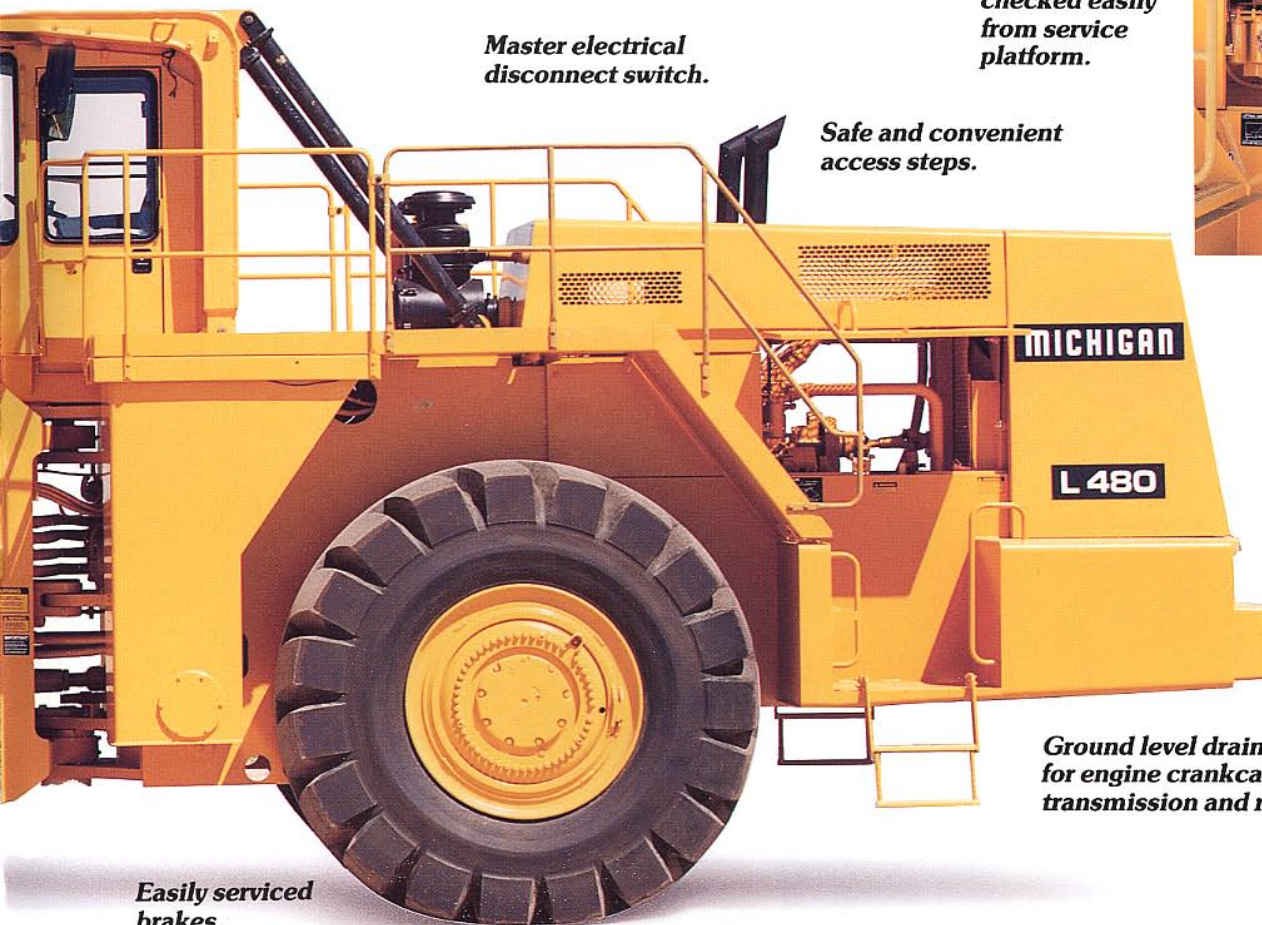

Master electrical disconnect switch.

Safe and convenient access steps.

Hinged radiator grill and side panels for easy cleaning.

Ground level drains for engine crankcase, transmission and radiator.

Easily serviced brakes.



The Michigan L320, L480, and L480T loaders have been designed and developed to meet your needs for a heavy duty production loader, backed by a world-wide network of distributors for parts and service when you need them.

Under our policy of continuous product improvement, we reserve the right to change specifications and design without prior notice. The illustrations do not necessarily show the standard version of the machine.

VME Americas Inc.

A subsidiary of VME Group N.V.

23001 Euclid Avenue
P.O. Box 178017
Cleveland, Ohio 44117-8017



FORM NO. L-131-1
DATE 8/88
Printed in U.S.A.