

BM-VOLVO

LOADER LM 640

4-wheel drive — compact — nimble — unmatched versatility



The BM-VOLVO LM 640 is an easily manoeuvred, 4-wheel drive loader featuring torque converter and hydraulically operated gearbox. The large wheels and traction power of the machine eliminate the risk of bogging-down when ground conditions are bad. This loader therefore stands out in its class as a tool for earth-moving jobs, loading and general-service work.

The compact, nimble design of the LM 640 makes it very versatile. Being a part of the BM-VOLVO loader system, it can be combined with implements that match it to a very wide range of needs in materials handling and allied fields.

An all-rounder!

Nimble handling, speed couplings for implements and geometry that offers long outreach plus good lifting height — these are typical characteristics of BM-VOLVO loaders and have permitted the development of a range of implements that is unique in the loader field.

The LM 640 can exploit the entire range — some 70 implements in all — and together with excellent keep-moving ability this makes it a true all-rounder, capable of efficient performance in widely varying spheres of work.





Speed coupling!

Changing implements in less than a minute is possible due to the speed coupling — a design refinement that is one of the reasons why BM-VOLVO loaders can meet so many different needs. Quick switching of implements also gives the advantage that the machine can change duties frequently. This is essential if full utilization is to be achieved. The LM 640 can also be equipped with hydraulic remote control of the implement speed coupling, operated from the driver's seat, which means that the driver can change implements without leaving his cab.

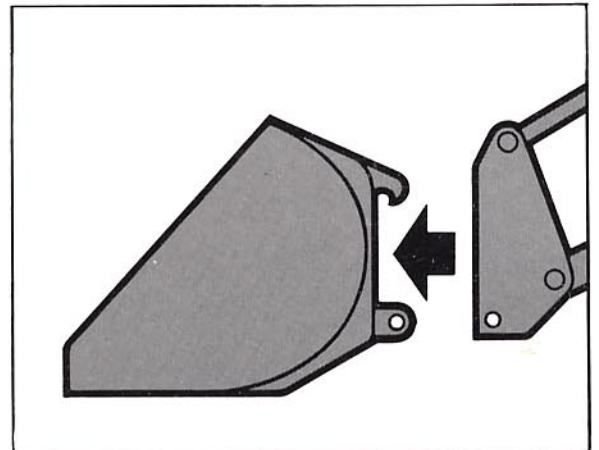



4-wheel drive — keeps the machine moving!

4-wheel drive means considerably improved performance when ground conditions are bad — slippery or muddy. The big wheels, with correspondingly increased floatation, add to this ability. The LM 640 is also equipped with a rugged differential lock.

The LM 640 features a torque converter that automatically multiplies the torque as the load increases. Together with the distribution of tractive power between the four big wheels, the LM 640 thus achieves unique penetration and efficient bucket filling.



Generous reach— high lift!

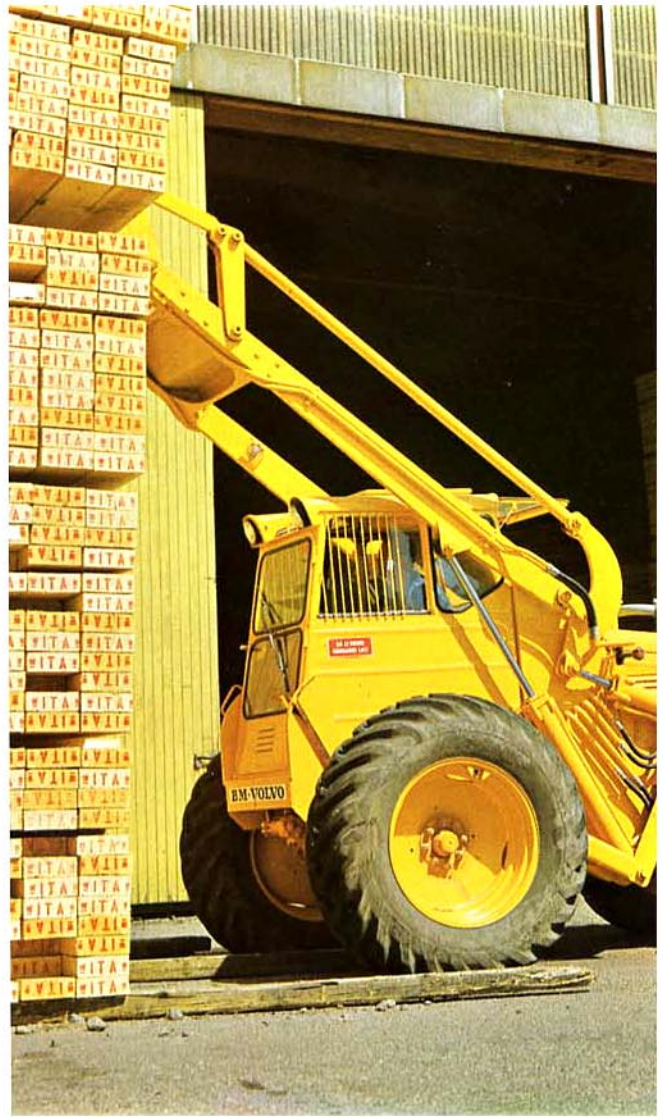

An LM 640 has no trouble lifting loads over wide platforms and onto high stacks, thanks to the geometry of the lifting gear. This affords generous reach and high lift, with good visibility at all positions. In off-the-road work

and on confined sites, the nimble handling of the machine combines with excellent reach and lift to improve efficiency and simplify materials handling.



Good visibility— comfort—safety— tight turning!

The safety cab is designed to afford the driver good visibility and full control of the implements in all positions. The controls are easily accessible and designed for natural, non-fatiguing operation. Ventilation and heating are excellent. Both side and rear windows can be opened. There is an escape hatch in the roof. Side windows are protected by grilles. The comfortable driver's seat is adjustable.

The wide steering lock of the LM 640 gives a tight turning radius — only 18 ft — which in turn means fast working cycles and high output. Yet despite its tight turning radius, the long wheelbase of the LM 640 also ensures safe, steady driving.

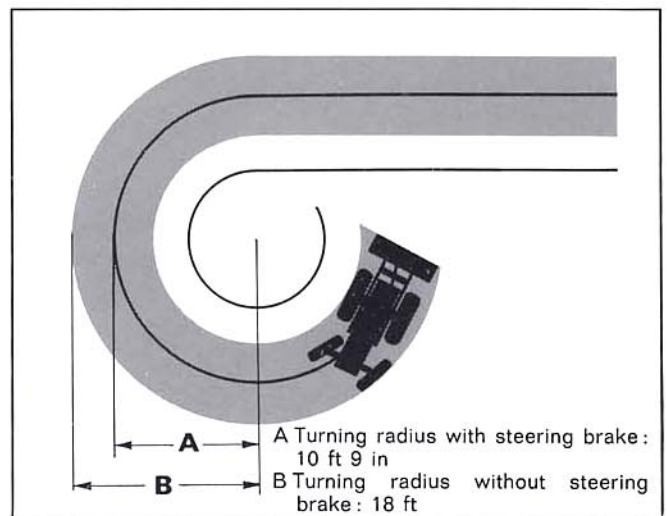



Dimensions

| | |
|---|------------|
| A | 17' 8" |
| B | 4' 10 1/4" |
| C | 7' 6 1/2" |
| D | 1' 1" |
| E | 1' 1 1/2" |
| F | 8' 3 1/4" |
| G | 6' 6 3/4" |
| H | 9' 6" |
| J | 11' 5 3/4" |
| K | 12' 7 1/2" |
| L | 14' 9 1/2" |
| M | 2' 3/4" |
| N | 4' 7" |
| O | 43° |
| P | 43° |
| R | 42° |
| S | 41° |

Reliable and economical engine!

The BM-VOLVO LM 640 is powered by a tough 3-cylinder diesel featuring direct injection. The engine is solidly crafted, to a well-proven and thoroughly tested design. In combination with the torque converter, the powerful engine delivers full pulling power and efficiently utilizes its power potential. Daily maintenance is simple and takes little time, since the 'open' design of the machine makes all inspection points easily accessible.

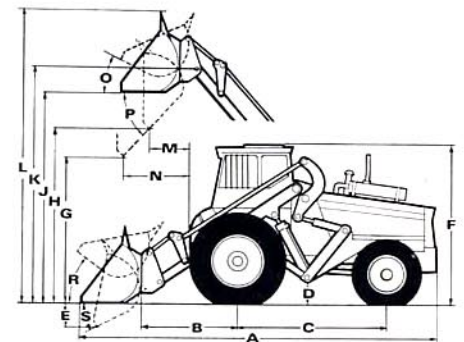

Specification, LM 640

General data

| | |
|---------------------------|---------------------------------|
| Gross weight incl. bucket | 14,550 lb |
| Wheelbase | 7 ft 6 1/2 in |
| Track, front/rear | 5 ft 8 1/2 in/ 5 ft 8 1/2 in |
| Turning radius | 18 ft |
| Tyres, front | 16.9—30/10 |
| Tyres, rear | 12.4—24/10 |

Engine

| | |
|--|----------------------|
| 3-cyl., 4-stroke, direct-injected diesel | |
| Type | BM-VOLVO 1113 ALH |
| Capacity | 230 cu.in. |
| Max. output at 2,200 rev/ min SAE/DIN | 69/63 hp |
| Max. torque, SAE/DIN | 181/171 lb-ft |

Transmission

Torque converter and hydraulic servo-operated gearbox. Dual speed ranges giving a total of 4 speeds both forward and reverse.
Hand-operated differential lock
Speed ranges, forward/reverse, miles/h
I 0—4.0
II 0—6.5
III 0—11.3
IV 0—18.4

Loader gear

| | |
|---|----------------|
| Bucket capacities | 1—4 cu.yd. |
| Reach at 6 ft 6 3/4 in height, approx. | 4 ft 7 in |
| Max. clearance under dumped bucket | 9 ft 6 in |
| Load over height | 11 ft 7 3/4 in |

Hydraulics

| | |
|-------------------------------|----------------------|
| Capacity of pump | 30.8 Imp.gal/ min |
| Working pressure of system | 1280 lb/sq.in |

Brakes

Fully enclosed disc brakes; separately operated driving and parking brakes.

Standard equipment

Safe, comfortable cab with rubber mat and inside rearview mirror, engine-hour wipers on upper and lower screen meter, sun vizard, fuel gauge, 460 W, a.c. generator, three hydraulic outlets complete with piping and controls, directional indicators, elec. windscreen wipers, fresh air ventilation and heating unit, power assisted steering, steering

brakes, differential lock, twin headlamps at both front and rear, tail lights, parking lights, marker lights, electric plug for trailer, horn, safety grilles.

Optional equipment

4th hydraulic outlet with piping and separate control lever for 4th function or combined control for 3rd and 4th functions, complete hydraulic piping for trailer dumping, engine preheater of 750 W immersion type, rotating flasher light, extra working lights, GN suspension for driver's seat, hydraulically operated implement carrier, industrial towing hook.

The manufacturers reserve the right to change specification and details without notice.



BM-VOLVO LM 640 ***universal loader***

- Nimble, easily manoeuvred
- 4-wheel drive, no bogging down
- Large wheels give low ground pressure, good floatation and allow fast travel even over rough ground
- Solidly-built, reliable engine
- Torque converter multiplies torque as load increases
- Power-Shift gearbox for fast, easy changing
- Speed coupling, implements changed in a minute
- Wide range of implements — about 70 units
- Comfortable cab offers good visibility, heating and ventilation
- Tight turning radius, fast working cycles in confined spaces
- Easy servicing, all daily inspection points readily accessible



BOLINDER-MUNKTELL

— member of the Volvo Group, Eskilstuna, Sweden