

# **BM-VOLVO**

**LOADER LM 621**





# **BM-VOLVO LM 621**

## **– the 2-wheel drive Allrounder**

### **based on thousandfold experience**

More than 20 000 BM-VOLVO Allrounders are operating today in all parts of the world. They are utilized for innumerable tasks under the most varied conditions — from arctic cold to tropical heat. This has provided the staff of experts responsible for the design and further development of the BM-VOLVO Allrounders with a rich store of experience and observations. This continuous product development means that the BM-VOLVO Allrounders are further consolidating their leading position.

The BM-VOLVO LM 621 is a 2-wheel drive Allrounder whose prime features are superior versatility, high lift, long outreach, tight turning circle, a reliable, powerful BM-VOLVO diesel engine and quick action. All these contribute to the superior capacity and profitability which have made BM-VOLVO Allrounders a concept of quality.





# quick! high lift! long outreach!

The LM 621 is quick and easy to operate and drive with precision. The loader unit lifts to a height of 142 in (3.6 m) and with the high-lift attachment (shown in the picture) loads can be delivered up to a height of 275 in (7 m).



The outreach ahead of the tyres is long, enabling simple and rapid loading and unloading from truck platforms and railway wagons from one side. The parallel side-arm action in combination with high figures for lift and outreach make the loader ideal for handling palletized loads and timber. Consequently, the LM 621 is the obvious loader for construction sites, goods terminals, ports and for industrial applications.

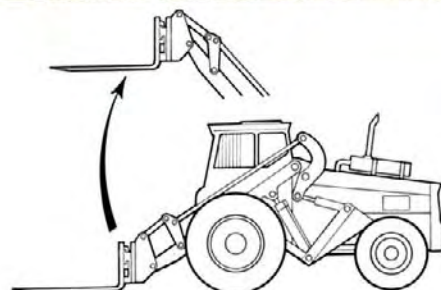





# all-round...

Characteristic features of the BM-Volvo Allrounders are their nimbleness, the snap-on coupling on the attachment bracket and the design of the side arms which provides long outreach and high lift. These properties have enabled the development of a range of attachments which is singularly comprehensive for loaders and is continuously being extended to embrace ever more units. For the LM 621 owner, this means both that he can utilize his loader for a variety of tasks and that he can select an attachment adapted specifically to the task involved.

Rapid attachment changes are made possible by the snap-on coupling of the attachment bracket fitted as standard equipment — an exclusive design feature which makes the LM 621 a truly all-round loader for building firms, industrial plants, local authorities, etc. Its efficiency in crane jobs, pallet handling, snow clearance, bucket loading, timber handling and numerous other tasks enables the loader to be utilized effectively the year round with superior profitability as a result.

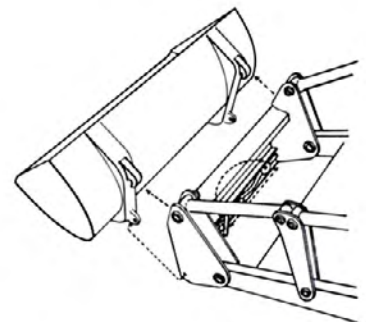







The driver's cab on the LM 621 is safe and comfortable and satisfies current international standards. A low noise level has been achieved in that the cab is extremely airtight, well insulated and rubber-mounted. Wide foot steps and a large door ensure easy entry. The carefully arranged driver's cab is spacious and the wide windows offer excellent all-round visibility. The driver's seat is adjustable vertically and for leg-room to provide the best possible driving position. Hydrostatic steering along with correctly located controls and instruments make the cab a comfortable, safe and pleasant work station.

# safety! driver comfort!

For colder climates the LM 621 may be fitted with a highcapacity heating unit mounted under the seat — a location which ensures extremely uniform and effective distribution of the hot air. The fan has two speeds.



## tight turning radius

The large steering angle of the steering wheels on the LM 621 provides a tight 16 ft 6 in (5 m) turning radius, which means short work cycles and thereby a high working capacity. The tight turning radius also makes the loader very agile on cramped work sites. Despite its tight turning radius, the loader has a long wheel base for reliable and stable road-holding.

- A turning radius with steering brake 10 ft 8 in (3.25 m)
- B turning radius without steering brake 16 ft 6 in (5.0 m)

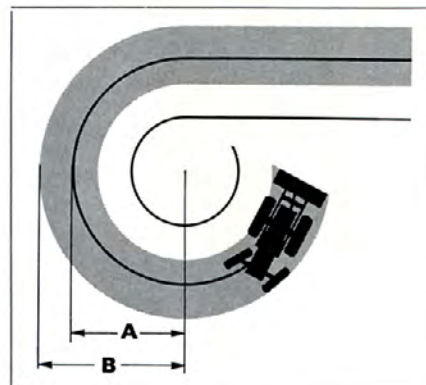



# new, powerful engine!

The LM 621 is powered by a completely new 4-cylinder, direct-injection BM-Volvo diesel engine developing 80 hp SAE at 2 300 rev/min.

Wet, replaceable cylinder liners, aluminium alloy pistons and a crankshaft carried in five case-hardened bearings ensure high resistance to wear. The exceptionally vibrationless running of the engine is due to a special balancing mechanism.

The injection pump is fitted with an automatic cold starting device. The air cleaner is composed of a dry filter and a centrifugal separator with a high filtering effect. An alternator guarantees battery charging even at low engine speeds.



## Specifications BM-VOLVO LM 621

### Engine

BM-VOLVO 4-cylinder, 4-stroke diesel engine with direct injection, type ....	D 42
Hp rating at 2 300 rev/min	80 hp SAE
Max. torque at 1 300 rev/min	198 lbf ft (27.4 kgf m) SAE
Displacement	256.3 in <sup>3</sup> (4.2 litres)
Bore	4.155 in (105.57 mm)
Stroke	4.33 in (120 mm)
Compression ratio	17.5:1
Air cleaner	Centrifugal separator with dry filter element, pressure drop indicator

### Electrics

Voltage	24 V
Alternator	700 W
Starter	4 hp
Transistorized charging relay	
Safety start device	

### Torque converter

Single stage, single phase with 3.3:1 stall ratio

### Transmission

Full Power-Shift in two ranges with four forward and four reverse speeds

### Speeds

Forward and reverse in miles/h (km/h)	
I	0—4.8 (0—7.7)
II	0—7.5 (0—12.0)
III	0—11.8 (0—19.0)
IV	0—18.6 (0—30.0)
Differential lock	

### Tyres

Standard: front	16.9—30/14
rear	9.00—20/10

### Steering

Full power steering, type	Orbitrol
Turning radius	16 ft 5 in (5.0 m)

### Brakes

Hydraulic disc brakes, fully enclosed	
Parking brake	

### Hydraulics

Hydraulic pump, type	Hamworthy
Capacity	32 Imp. gal/min (145 l/min)
Working pressure (low pressure system)	1422 lbf/in <sup>2</sup> (100 kgf/cm <sup>2</sup> )
Oil tank capacity	19.8 Imp. gal (90 l)
Lifting cylinders, bore X stroke	3.94×35.32 in (100×897 mm)
Tipping cylinders, bore X stroke	4.33×13.27 in (110×337 mm)

### Operating data\*

Max. lifting height under tipped bucket	9 ft 6 in (2.90 m)
Outreach at a height of 6 ft 6 in (2 metres)	4 ft 7 in (1.40 m)
Carrying capacity	6 390 lb (2 900 kg)
Bucket capacities	1 1/4—4 yd <sup>3</sup> (0.95—3.0 m <sup>3</sup> )

\* The capacity figure is based on rear tyres without calcium chloride solution.

### General data

Total weight with bucket	15 900 lb (7.200 kg)
Wheel base	7 ft 8 in (2.35 m)
Track, front	5 ft 9 in (1.76 m)
rear	5 ft 6 in (1.70 m)
Ground clearance	1 ft 2 in (0.35 m)
Fuel tank capacity	24 Imp. gal (110 litres)

### Standard equipment

Safety cab, spring-cushioned seat, heater with fresh air intake, windscreen wipers, rear-view mirror in cab, twin headlights front and twin working lights rear, parking lights, tail and brake lights, direction indicators, position lights, flashing warning lights, horn, sun visor, engine hour recorder, fuel gauge, alternator, parking brake indicator light, differential lock, steering brake, snap-on attachment bracket with mechanical locking pipe set for 3rd hydraulic function, dry air filter with pressure drop indicator, neutral start ignition switch.

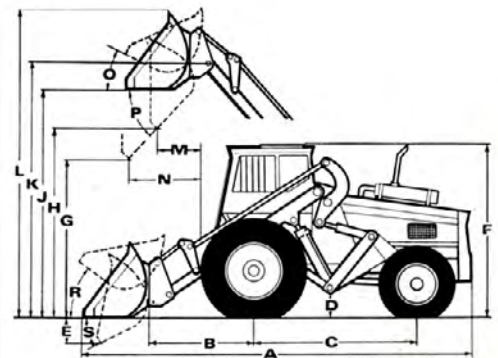

### Dimensions

A	18'1 1/4" (5550 mm)	K	12'7 1/2" (3850 mm)
B	4'9" (1450 mm)	L	15'5 1/2" (4700 mm)
C	7'8 1/2" (2350 mm)	M	2'6" (750 mm)
D	1'1 1/4" (350 mm)	N	4'7" (1400 mm)
E	2'5" (710 mm)	O	41°
F	8'7 3/4" (2640 mm)	P	45°
G	6'6 3/4" (2000 mm)	R	42°
H	9'6" (2900 mm)	S	42°
J	11'9 1/4" (3600 mm)		

### Optionals

Socket for trailer, snap-on attachment bracket with hydraulic locking, rotating flashing beacon, front working light, industrial towing hook, air-compressor for trailer brake system, outlet for trailer brake, tyre pump, spark arrester, safety belt, floatation tyres, heavy duty tyres, belly guards.

Specifications and design are subject to alteration without prior notice.





# BM-VOLVO LM 621

## a fast, effective all-round loader

- Versatile owing to the snap-on coupling on the attachment bracket which enables attachment changes within a minute. Wide range of standard attachments — approx. 70 different units.
- Large wheels give a low ground pressure — an advantage on ground with poor bearing capacity. Small angle of climb over obstacles. Rugged differential lock for reliable off-road performance.
- Comfortable, safe driver's cab with a low noise level. Excellent visibility, heating and ventilation.
- Torque converter and Power-Shift gearbox — fast, simple gear changes without use of a clutch pedal. Automatic increase in torque as resistance increases.
- Carefully designed loader unit which combines long outreach with high lift. Parallel side-arm action and good bucket angles.
- 80-hp BM-VOLVO diesel engine. Four cylinders and a balancing mechanism ensure virtually vibrationless running.



**BOLINDER-MUNKTELL**

— a member of the Volvo Corporation,  
Eskilstuna, Sweden

Nr 2203 AE