

SCAT TRAK[®]

SKID STEER LOADERS

2300D
2300DX

SKID STEER LOADERS

High Performance

- ▶ 2300-2450 lb. operating load capacity
- ▶ Able to handle a 2000 lb. pallet of block, brick or sod
- ▶ Servo transmission control for reduced lever effort, quieter operation
- ▶ High efficiency Perkins 86 hp diesel engine
- ▶ Powerful 22 GPM hydraulic pump for fast cycle times, more power to run optional attachments
- ▶ 2300DX offers 33 GPM pump for high flow hydraulics
- ▶ In-line loader linkage for excellent bucket visibility
- ▶ Self-leveling bucket (lift only)

Easy Access

- ▶ Forward tilting ROPS/FOPS cab allows quick and easy access to engine/hydrostatic and hydraulic components
- ▶ Swing out tailgate, hinged top engine cover, lift out floor panel, and drive chain access plates for excellent access to all key components

Durable Design

- ▶ Welded unitized frame, modular axles, corrosion resistant pivot pins, rugged Quick-Attach system, sealed Teflon bushings and lubed-for-life universal joint

Operator Comfort

- ▶ Extra wide operator compartment
- ▶ Convenient hand and foot controls standard (wrist action controls optional)
- ▶ Easy entrance and exit (no center cylinder to step over)
- ▶ Easy to read gauge/warning light panel

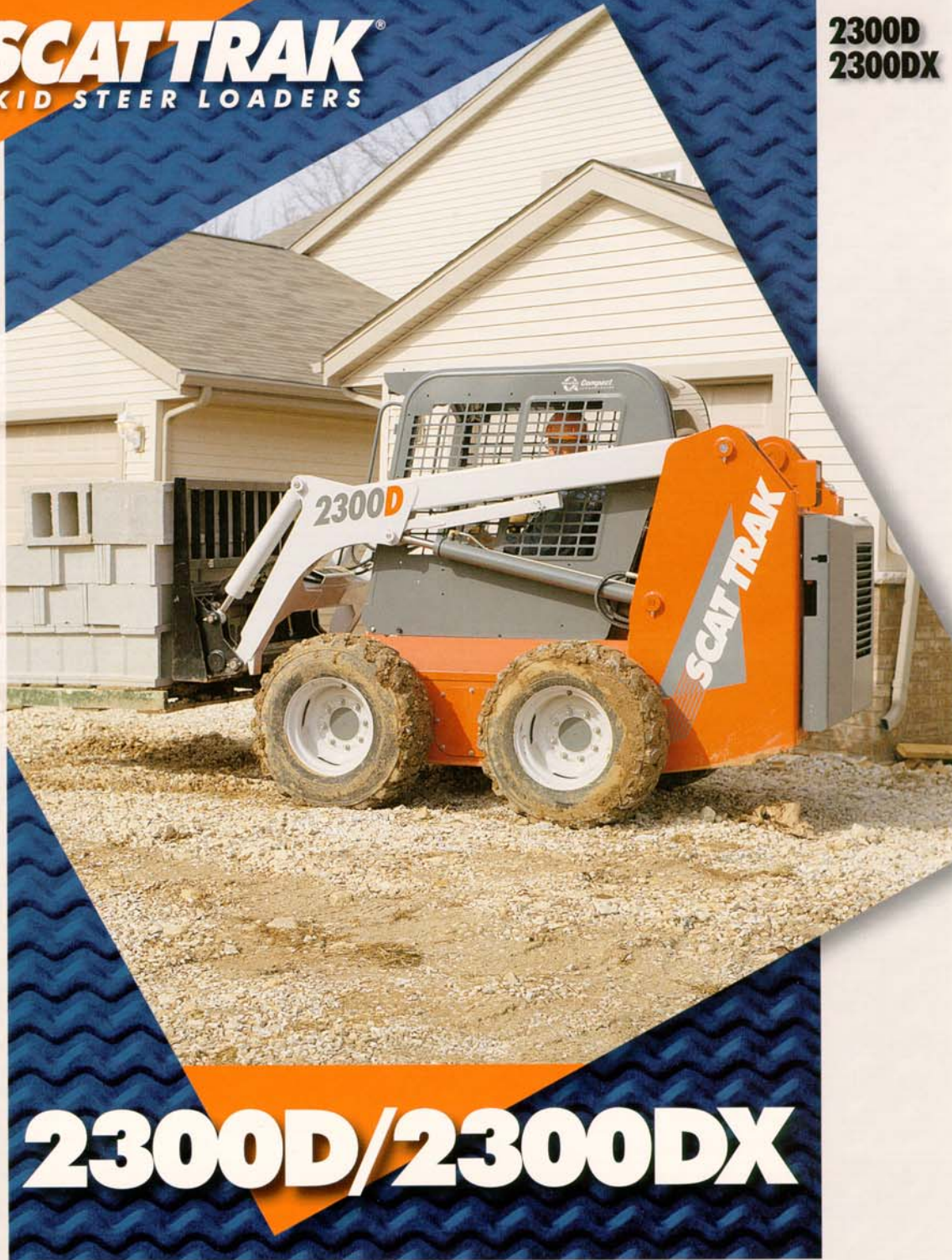

2300D/2300DX



The 22 GPM hydraulic pump delivers plenty of power for optional attachments.



The in-line loader linkage provides excellent bucket visibility.



A wide range of versatile attachments are available.

SCATTRAK®

SKID STEER LOADERS

2300D 2300DX

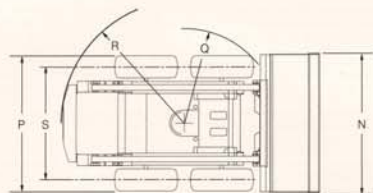

ZF0012

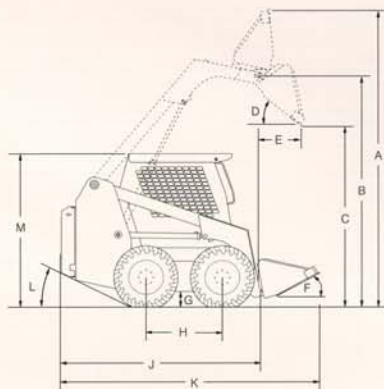

ZN0012

Dimensions

A. Overall operating height (with dirt bucket 72" [1829 mm])	158.4" (4023 mm)
B. Height to hinge pin	121" (3073 mm)
C. Dump height	94.1" (2390 mm)
D. Dump angle	37°
E. Dump reach	24.2" (615 mm)
F. Maximum roll back	30°
G. Ground clearance	7.4" (188 mm)
H. Wheelbase	43.4" (1102 mm)
J. Overall length (less bucket)	112.0" (2845 mm)
K. Overall length (with dirt bucket)	140.8" (3576 mm)
L. Angle of departure	26°
M. Overall height @ ROPS	80.5" (2045 mm)
N. Bucket width (inside dimension)	72.0" (1829 mm)
P. Clearance width (less bucket) —	
8.25 x 15 tires	69.3" (1760 mm)
12.00 x 16.5 tires	71.8" (1824 mm)
14.00 x 17.5 tires	75.8" (1925 mm)
33.00 x 15.5 x 16.5 tires	80.4" (2042 mm)
Q. Front clearance circle (less bucket)	52.5" (1334 mm)
R. Rear clearance circle	66.0" (1676 mm)
S. Tread width	59.5" (1511 mm)

Engine

Perkins 1004.42,
4 cylinder liquid cooled diesel,
86 hp (64 kW) @ 2400 rpm
Displacement..... 258 cu in (4,2 liters)
Fuel tank capacity..... 22.5 gal (85,2 liters)

Travel Speed

Travel range
w/12.00 x 16.5 tires..... 0-6.3 mph (0-10,1 km/h)
w/14.00 x 17.5 tires..... 0-7 mph (0-11,2 km/h)

Operating Specs

**72" High Capacity Dirt Bucket
(heaped capacity 18.2 ft³)**
Operating capacity..... 2300 lb. (1043 kg)
Tipping load..... 4600 lb. (2086 kg)

**72" Standard Capacity Dirt Bucket
(heaped capacity 16.7 ft³)**
Operating capacity..... 2450 lb. (1111 kg)
Tipping load..... 4900 lb. (2223 kg)

Hydraulic pump flow rate..... 22 GPM (83 liters/min)
High flow hydraulics (DX only)
@ 3000 psi..... 33.0 GPM (124,9 liters/min)

Hydraulic reservoir capacity..... 17.3 gal (65 liters)
*Approx. operating weight (D)..... 7675 lb. (3481 kg)
*Approx. operating weight (DX)..... 7775 lb. (3527 kg)

*Full fuel tank, 165 lb. (75 kg) operator, 72" (1829 mm) standard capacity dirt bucket, 12.00 x 16.5 — 10-ply heavy duty tires

Standard Equipment

- ▶ Quick-Attach mounting frame
- ▶ Auxiliary hydraulics with flat face couplers
- ▶ Adjustable seat with 2" seat belt
- ▶ Operator restraint bar
- ▶ Dual travel/steering levers
- ▶ Tilt forward ROPS/FOPS cab
- ▶ Emergency exit rear window
- ▶ Mechanical park lock
- ▶ Loader arm service support
- ▶ Electronic loader arm lockout
- ▶ Hydraulic attachment self leveling (lift only)
- ▶ Dual element air cleaner
- ▶ Thermal start kit
- ▶ Back-up alarm
- ▶ 12.00 x 16.5 — 10-ply heavy duty flotation tires
- ▶ Lockable doors and covers
- ▶ Dual 12-Volt (525CCA) batteries
- ▶ Halogen work lights — two front/one rear
- ▶ 55 amp alternator
- ▶ Fuel gauge
- ▶ Hourmeter
- ▶ Warning light system
 - ▶ Engine water temperature, engine oil pressure and hydraulic oil temperature with audible alarm
 - ▶ Electrical charging system, transmission temperature, air filter restriction indicator, hydraulic filter bypass indicator and pre-heat indicator

Options

- ▶ 14.00 x 17.5 — 14-ply heavy duty flotation tires
- ▶ 33.00 x 15.5 x 16.5 — 12-ply super wide flotation tires
- ▶ 8.25 x 15 non-pneumatic segmented tires
- ▶ 12.00 x 16.5 non-pneumatic segmented tires
- ▶ 8.00 x 16 non-pneumatic solid tires
- ▶ Over tire metal tracks
- ▶ 4-point lift hooks
- ▶ Spark arresting muffler
- ▶ Engine block heater
- ▶ Hydraulic reservoir heater
- ▶ Dual 12-Volt (800CCA) heavy duty batteries
- ▶ Catalytic exhaust purifier
- ▶ Engine air intake pre-cleaner
- ▶ Top window
- ▶ Cab enclosure with heater, defroster and wiper
- ▶ Special applications front door
- ▶ Deluxe seat
- ▶ Amber strobe light
- ▶ Horn
- ▶ 3" seat belt
- ▶ Wrist action hand controls
- ▶ Engine automatic shutdown system



901 Sunset Road
Port Washington, Wisconsin 53074 USA
(262) 268-3250 Fax: (262) 284-1153
www.compact-technologies.com

WE RESERVE THE RIGHT TO AMEND THESE SPECIFICATIONS AT ANY TIME WITHOUT NOTICE. THE ONLY WARRANTY APPLICABLE IS THE STANDARD WARRANTY PERTAINING TO A PARTICULAR PRODUCT AND SALE. WE MAKE NO OTHER WARRANTY EXPRESSED OR IMPLIED.

The OmniQuip Family Includes:
**SKYTRAK®, SNORKEL®, LULL®,
and SCATTRAK®**