

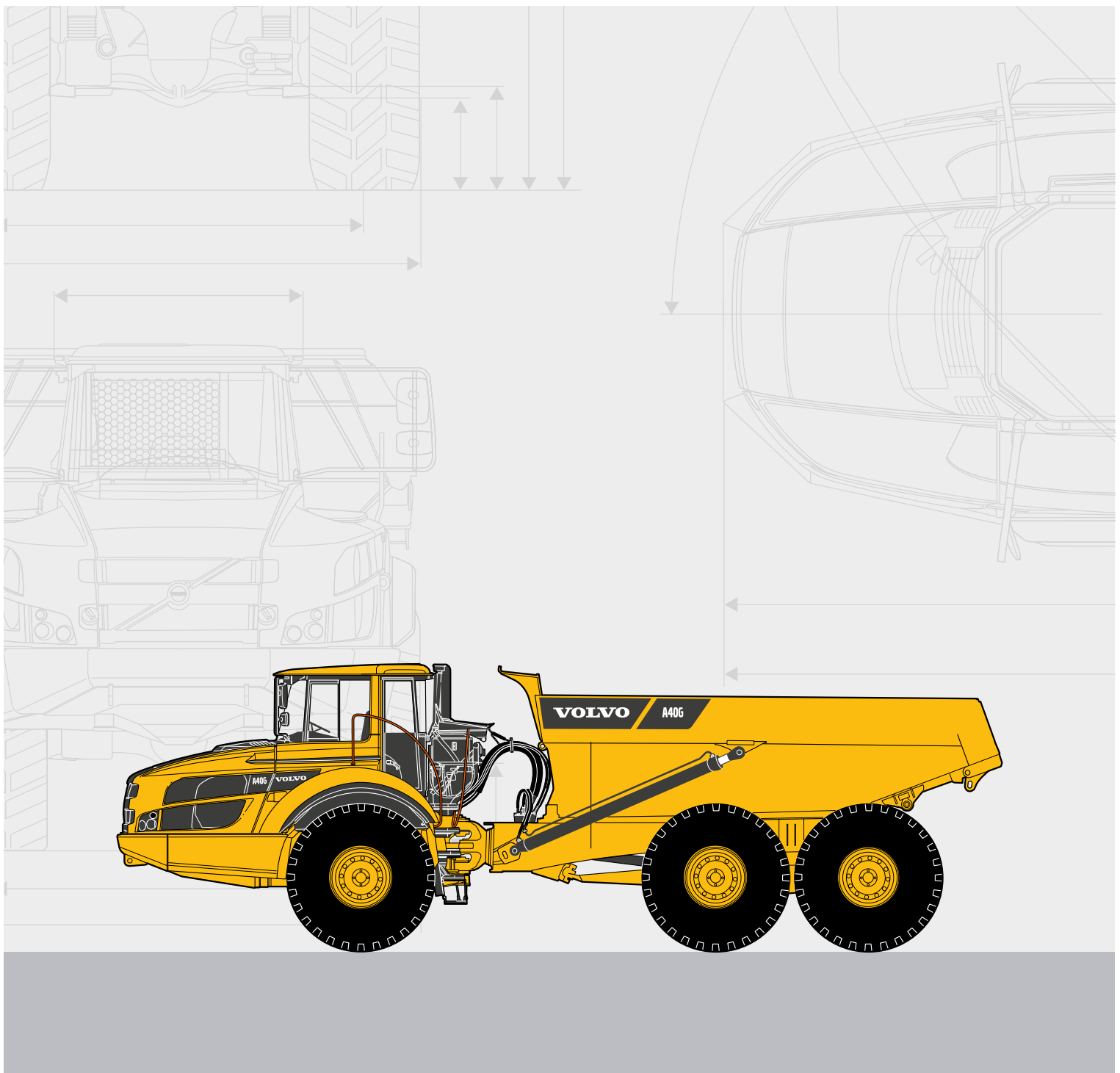

ENVIRONMENTAL DECLARATION

VOLVO ARTICULATED HAULERS



Environmental Declaration

Articulated Haulers

The following information is specified by the manufacturer and applies to machines when they are delivered/leave the factory.

Manufacturer:

Volvo Construction Equipment AB
SE-631 85 Eskilstuna
Sweden

For other technical information, see product specification as well as the Operator's Manual.

Model		A25G	A30G	A35G	
Engine type (Tier 4f US)		Volvo D11M	Volvo D11M	Volvo D13J	
Engine type (Stage V EU)		Volvo D11M	Volvo D11M	Volvo D13J	
Engine power, ISO 9249, SAE J1349 net	kW	234	264	333	
	Metric hp	318	359	453	
	Imperial hp	314	354	447	
Transmission		Volvo PT 2116	Volvo PT 2116	Volvo PT 2519	
Dropbox		Volvo IL1 ATC	Volvo IL1 ATC	Volvo IL2 ATC	
Model		A40G	A45G	A45GFS	A60H
Engine type (Tier 4f US)		Volvo D13J	Volvo D16J	Volvo D16J	Volvo D16J
Engine type (Stage V EU)		Volvo D13J	Volvo D16J	Volvo D16J	Volvo D16J
Engine power, ISO 9249, SAE J1349 net	kW	347	354	354	467
	Metric hp	472	481	481	635
	Imperial hp	465	475	475	626
Transmission		Volvo PT 2519	Volvo PT 2519	Volvo PT 2519	Allison 6630 ORS
Dropbox		Volvo IL2 ATC	Volvo IL2 ATC	Volvo IL2 ATC	Volvo IL3 ATC
Model		A25G	A30G	A45G	A45GFS
Engine type (Stage III)		Volvo D11E	Volvo D11E	Volvo D16E	Volvo D16E
Engine power, ISO 9249, SAE J1349 net	kW	234	264	354	354
	Metric hp	318	359	481	481
	Imperial hp	314	354	475	475
Transmission		Volvo PT 2116	Volvo PT 2116	Volvo PT 2519	Volvo PT 2519
Dropbox		Volvo IL1 ATC	Volvo IL1 ATC	Volvo IL2 ATC	Volvo IL2 ATC
Model		A25G	A30G	A35G	
Engine type (Stage II)		Volvo D11F	Volvo D11F	Volvo D13F	
Engine power, ISO 9249, SAE J1349 net	kW	234	264	333	
	Metric hp	318	359	453	
	Imperial hp	314	354	447	
Transmission		Volvo PT 2116	Volvo PT 2116	Volvo PT 2519	
Dropbox		Volvo IL1 ATC	Volvo IL1 ATC	Volvo IL2 ATC	
Model		A40G	A45G	A45GFS	A60H
Engine type (Stage II)		Volvo D13F	Volvo D16F	Volvo D16F	Volvo D16F
Engine power, ISO 9249, SAE J1349 net	kW	347	354	354	492
	Metric hp	472	481	481	669
	Imperial hp	465	475	475	660
Transmission		Volvo PT 2519	Volvo PT 2519	Volvo PT 2519	Allison 6630 ORS
Dropbox		Volvo IL2 ATC	Volvo IL2 ATC	Volvo IL2 ATC	Volvo IL3 ATC

Core Values

Along with quality and safety, caring for the environment is one of Volvo's core values. This means that Volvo Construction Equipment works with an overall perspective of the products that extends throughout their entire life cycle. This includes engineering and design, material selection, manufacturing processes, use, and recycling.

Manufacturers

Manufacturing of the main components - engines, transmissions, drive axles and cabs as well as assembly of complete articulated haulers takes place at production facilities of Volvo Construction Equipment. All of these are certified according to ISO 14001. A lot of our components and parts are purchased from external suppliers. Volvo Construction Equipment works in close cooperation with these suppliers in order to ensure that purchased components and parts meet our environmental requirements.

Declarations

Upholstery and other cab materials do not contain mercury. Plastics and other interior materials are fire-classed according to Volvo standard 104-0001.

Brake pads do not contain mercury, cadmium, or asbestos. The complete machine does not contain any cadmium or asbestos. If the machine is equipped with air conditioning (option), refrigerant type R134a (2.0-2.3 kg/4.4-5.1 lbs) is used.

Tires

Tires do not contain highly aromatic oils (HA-oils) in the tread.

Paint and Surface Treatment

In order to reduce consumption of water and chemicals, cleaning and recirculation takes place during the treatment processes in the factories.

Specification of paint

Main components	Paint type	Chlorine	Pre-treatment
Cab	Electrocoat + TopPowder	No	Degreasing, Pickling, Zinkphosphating
Frames and load body (load carrying structure)	2K epoxy Direct-To-Metal	No	Steel shot blasting
Axles	2K waterborne epoxy primer+2K waterborne PUR Topcoat	No	Iron phosphating

Environmental Declaration

Engine/emissions

Stage V: the engine is certified through official testing according to regulation (EU) 2016/1628 and ECE R96: Stage V.

Exhaust emissions are measured as specific emission in g/kWh according to non-road stationary test cycle (NRSC) C1 version and the non-road transient cycle (NRTC).

Tier 4f: the engine is certified according to USA requirements non- and off-road (40 CFR 1039 and 40 CFR 1068): EPA and CARB Tier 4f.

Exhaust emissions are measured as specific emission in g/kWh according to non-road ramped cycle (RMC) C1 version and the non-road transient cycle (NRTC).

In order to achieve the legal requirements, the after-treatment of exhaust emissions is required.

Emission levels	NOx (g/kWh)	HC (g/kWh)	PM (g/kWh)	CO (g/kWh)	PN (g/kWh)	Power range (kW)
EU, Stage V	0.4	0.19	0.015	3.5	1x10 ¹²	130-560
US EPA + CARB Tier 4f	0.4	0.19	0.02	3.5		130-560
Stage III		4.0	0.2	3.5		130-560
Stage II	6.0	1.0	0.2	3.5		130-560

The load-sensing working hydraulics contribute to lower fuel consumption through a demand-controlled flow of hydraulic oil.

Sound levels

Sound level in cab is measured according to ISO 6396.

External sound level is measured according to ISO 6395.

The appropriate decals with sound level in cab and external sound level are found on the machine.

Model	A25G	A30G	A35G	A40G	A45G A45G FS	A60H
Sound level in cab dB(A)	72	72	72	72	72	72
External sound level, dB(A)	110	111	112	112	112	113
External sound level, dB(A) with Noise Reduction Kit*	108	109	110	110	110	111

* Noise Reduction Kit is required to fulfil EU directive 2000/14/EC with supplement 2005/88/EC. All machines, featuring CE marking (specified for sale within the EU) are equipped with it from 2006.

Operator's Environment

Incoming air for the cab first passes through a pre-filter, which separates out coarser particles. It then passes through the main filter in the cab. Up to 90% of all air can be recirculated through the main filter. This creates an overpressure in the cab, ensuring no air entering the cab bypasses the filter system. This guarantees clean working environment.

Service

To facilitate draining and reduce the risk of spilling engine and hydraulic oil, a special drain hose is supplied with each machine. There is a breather filter to reduce oil mist for venting axles, transmission and hydraulic tank. The hydraulic tank as well as front and rear axles has a protective valve in the breather filter. This will minimize leakage in the event of a roll-over or turnover. The tank cap is closed tight to prevent fuel leaks in case of a roll-over or turn-over. All engines have a system for cleaning the crankcase emissions of oil particles and mist. For service intervals and other maintenance, see Operator's Manual for each machine model.

Oils and Fluids

Volvo Construction Equipment recommends Volvo Biodegradable Hydraulic Oil. If the Volvo oil is not available, please contact your Volvo dealer.

Recycling

The design of Volvo articulated haulers allows for recycling at the end of their useful life cycle. Materials can be reused in new Volvo haulers or other products. According to our own calculations, the machine is recyclable to 95% by weight. Most of our plastic parts are marked for recycling according to Volvo standards 5052,41; 5052,411; 5052,412; 103-0002 and ISO 1043-1, 1043-2, 1043-3, 1043-4, 1629.

Environmental Declaration

Recycling

The materials used in machines are divided into the following approximate weights:

Model	Units	A25G	A30G	A35G	A40G	A45G	A45GFS	A60H
Steel & iron	kg	17 000	17 500	22 150	22 800	23 450	22 850	33 614
	lb	37,485	38,588	48,841	50,274	51,707	50,384	74,119
Copper	kg	35	35	74	74	74	74	99
	lb	77	77	163	163	163	163	218
Aluminium	kg	72	72	100	100	100	100	147
	lb	159	159	221	221	221	221	324
Bronze bushings	kg	5	5	8	8	8	8	8
	lb	11	11	18	18	18	18	18
Lead batteries	kg	91	91	91	91	120	120	120
	lb	201	201	201	201	265	265	265
Glass	kg	75	75	75	75	75	75	75
	lb	165	165	165	165	165	165	165
Polymer materials & rubber	kg	118	118	123	123	123	87	194
	lb	260	260	271	271	271	192	428
Tires	kg	1 908	2 436	2 610	3 210	3 210	3 210	4 890
	lb	4,207	5,371	5,755	7,078	7,078	7,078	10,782
Fluids, oils & chemicals	kg	1 124	1 124	1 342	1 355	1 355	1 355	1 498
	lb	2,478	2,478	2,959	2,988	2,988	2,988	3,303
Other	kg	1 100	1 100	1 306	1 315	1 315	1 317	1 350
	lb	2,426	2,426	2,880	2,900	2,900	2,904	2,977
Total recyclable material*	kg	21 528	22 556	27 879	29 151	29 830	29 196	41 995
	lb	47,469	49,736	61,473	64,278	65,775	64,377	92,599
Recycling quota	%	95	96	95	95	96	96	96

* Varies depending on equipment, for example tires and load body.

The calculation of the weights is based on defined machines. Variations are caused by different equipment. These material fractions can be recycled (material and/or energy recycled) if applicable.

Producer Responsibility

In most countries today, there is a producer responsibility for our products, applicable to components such as batteries, tires etc. There are special regulations for these components.

For further information, please contact your dealer.

Machine model

Delivery date

Machine's serial number

Engine Type

Engine's manufacturing number

Place for stamp

