

V O L V O



Volvo Compact Wheel Loaders 4.5 t / 9,880 lb 64 hp

L20H

Volvo Construction Equipment

L20H



Power to perform



Travel up to 30 km/h (18.6 mph) with the fully automatic two-speed range hydrostatic drive and powerful engine - with diesel oxidation catalyst.

Tackle uneven terrains



Increase traction on unstable ground, the L20H feature a $38^{\circ} \pm 10^{\circ}$ articulated oscillating joint and operator controlled 100% differential locks on both axles.

Fully loaded



Access tight areas

The compact design of the L20H, with an 8,210 mm (323 inches) turning radius, allows for manoeuvrability in confined spaces.



Designed with safety in mind

The FOPS/ROPS certified Volvo cab is equipped with the largest air filter in the industry, a highly visible entrance step and single inching brake pedal.



More comfort to get more done

Enjoy all-around visibility and easy operation. The Volvo cab features a single lever that incorporates three functions, with flow sharing valve.

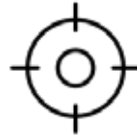

All-rounder compact loader

Volvo attachments are perfectly matched to the machine's linkage, hydraulics and driveline to increase productivity.



Maximize attachments use

For increased productivity and versatility, the Volvo SSL Attachment Bracket can be used with most Skid Steer attachments.



Less service, more work

Keep downtime to a minimum, with ground level greasing points, best-in-class components and long service intervals.



Here to support you

Keep your machine in fighting form, with a range of Genuine Volvo Parts, as well as maintenance and repair plans.



ActiveCare Direct

Maximize machine uptime and reduce repair costs with our ActiveCare Direct service, providing around the clock machine monitoring.



Small machine with big potential

Small in size but high in reach and dump height, the L20H is a great match for truck loading.

Volvo L20H in detail

Engine

The 4-cylinder Volvo common rail diesel engine is water-cooled, and compliant to EU Stage IIIB and EPA Tier 4 Final environmental regulations. An exhaust after treatment system and a Diesel Oxidation Catalyst are used. The engine is designed for high-performance cooling, facilitated by a main water-gallery and water passages between the cylinder bores. A Center Direct Injection System works as the combustion system, which provides increased injection pressure and a redesigned combustion chamber. The result is a 25% reduction of particles, which lowers the engine vibrations and radiated sound, and the total noise level.

Engine	Volvo	D2.6M
Max power at	r/min (r/s)	2,400 (40)
SAE J1995 gross	kW (hp)	48 (64.4)
SAE J1349, ISO 9249 net	kW (hp)	47.3 (63.4)
Max. torque at	r/min (r/s)	1,500 (25)
SAE J1995 gross	Nm (ft lbf)	225 (166)
SAE J1349, ISO 9249 net	Nm (ft lbf)	221.6 (163.4)
Economic working range	r/min (r/s)	1,500 (25)
Displacement	l (in ³)	2.62 (160)
Bore	mm (in)	87 (3.42)
Stroke	mm (in)	110 (6,712)

Electrical System

Contronic electrical system with central warning light and buzzer, providing clear and easy to read information to the operator. A keypad allows easy navigation on the central LCD display with main and sub information field. Indicators and activation lights are available for various control and monitoring functions. An audible warning alarm will sound and a central warning indicator will flash if abnormal operating values or error messages arise. Gauges are available for coolant temperature and fuel level. A fuse test port is available in the fuse box, allowing operators to perform initial investigations, reducing diagnostic time.

Voltage	V	12
Batteries	V	12
Battery capacity	Ah	100
Alternator rating	W/A	70
Starter motor output	kW	2.5

Drivetrain

The hydrostatic transmission allows a four-speed range change without tractive power interruption. Maximum tractive power is available in all speed ranges, regardless of the driving direction. The single 'inch brake pedal' offers variable machine speed control and a smooth transfer of power to the wheels, while maintaining a constant engine rpm. Using the multifunctional right joystick, easily reach the transmission's forward, neutral, reverse and differential locks buttons. The machine is designed for single-handed operation, providing the operator with excellent ergonomics and greater efficiency in all applications. Two rigid planetary axles provide durability. The central articulating-oscillating joint and all-wheel drive deliver excellent mobility across all ground conditions. The 100% differential lock on both axles ensures minimal tire wear when operating on hard ground and maximum traction force in soft terrain.

Angle of oscillation	± °	10
Oscillation at wheel, max.	mm (in)	226 (8.9)
Track	mm (in)	1,300 (51.2)

High-speed version

1st gear	km/h (mi/h)	7 (4.3)
2nd gear	km/h (mi/h)	30 (18.6)

Brake system

The reliable dual service brake applies to all four wheels: 1. Wear-free hydrostatic inching brake. 2. Central disc brake, actuated via the 'inch/brake pedal'. The first stage of the pedal application actuates the inching facility; the last third of pedal application applies the central disc brake. The independent, mechanically operated parking brake activates a central disc brake, which applies to all four wheels.

Steering System

The steering unit is designed in an open center system for high axial loads and high travel speeds. It has no mechanical connection between the steering unit and the articulating/oscillating joint. As a result, the external forces that affect the steering cylinder are absorbed without disrupting the driver's focus. Any reaction forces are absorbed via the steering wheel. Thanks to the dual hydraulic pumps, the speed of the working hydraulic (lifting/tilting) system is not influenced by the steering system.

Steering cylinders		1
Working pressure	MPa (psi)	21 (3,046)
Maximum flow	l/min (gal/min)	30 (7.93)
Max articulation	± °	38

Cab

The cab is tested and approved according to ROPS (ISO 3471, SAE J1040) and FOPS (ISO 3449) specifications. The cab is compliant with ISO 6055 requirements for operator overhead protection. The cab is also compliant with industrial trucks and SAE J386 regarding Operator Restraint System. The operator seat features adjustable suspension and a retractable seatbelt. Fresh air is filtered through large elements prior entering the cab, ensuring clean air distribution in the cab. Several air vents enable fast de-misting and defrosting. The contronic monitoring system provides important information and is located in a central position to ensure all machine controls are within the operator's field of vision.

Hydraulic system

Working hydraulics system with mechanical operated control valves. **System supplies:** a gear pump provides flow to the working hydraulics. **System control:** double-acting 3-spool main control valve. The lift function has four positions: lift, hold (neutral), lower and float. **The tilt function has three positions:** rollback, hold and dump. A fourth hydraulic function is available as an option to power the hydraulic implements (Hi-Tip bucket, angle sweeper, etc...). Filtration: full-flow filtration through 10 micron (absolute) filter cartridge in a combined suction-return-filter. Cooling: thermostatically controlled oil flow to the oil cooler (fast warm-up, optimized cooling).

Working pressure max	MPa (bar)	20 (200)
Flow	l/min (gal/min)	55 (14.5)
at engine speed	r/min (r/s)	2,400 (40)
High Flow Working pressure max	MPa (bar)	20 (200)
High Flow	l/min (gal/min)	110 (29)
at engine speed	r/min (r/s)	2,400 (40)

Linkage

The parallel linkage system offers 100% parallel lift with the loading fork. The linkage system and the attachment bracket are designed for an excellent visibility to the front attachment, fork tines and fork tines end.

Linkage system	Parallel Linkage System
Lift cylinders	2
Tilt cylinders	1
Lift time (loaded)	s 5.2
Lowering time (empty)	s 3
Dump time	s 3.9

Service Refill

The wide opening engine hood provides fast and easy service access. The redesigned counterweight features a service opening on the left side, offering excellent service access to the hydraulic pumps. The main fuse box and control valve are located behind the right-hand side hood. This service panel is locked with a key.

Fuel tank	l (gal)	60 (15.8)
Engine oil	l (gal)	10.2 (2.7)
Engine coolant	l (gal)	9.3 (2.4)
Hydraulic tank	l (gal)	59 (15.6)
Front axle oil	l (gal)	4.1 (1.1)
Rear axle oil	l (gal)	5.4 (1.4)

Wheels and tires

Size	335/80R18
Rim	11 x 18

Sound Level

Sound level in cab according to ISO 6396		
L _{pA}	dB	75
External sound level according to ISO 6395		
L _{WA}	dB	99

Specifications

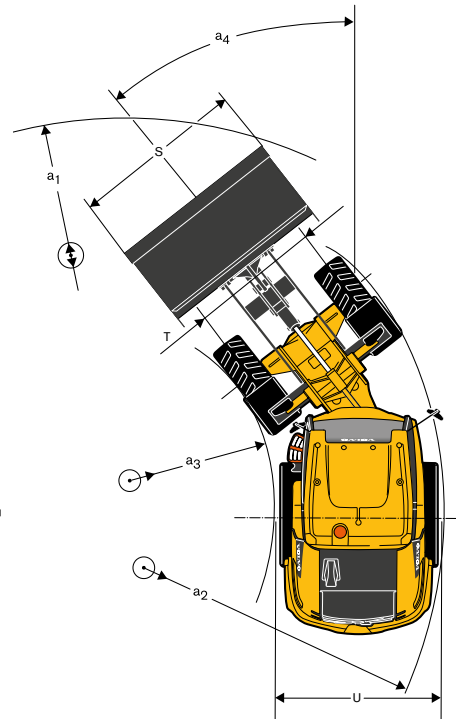
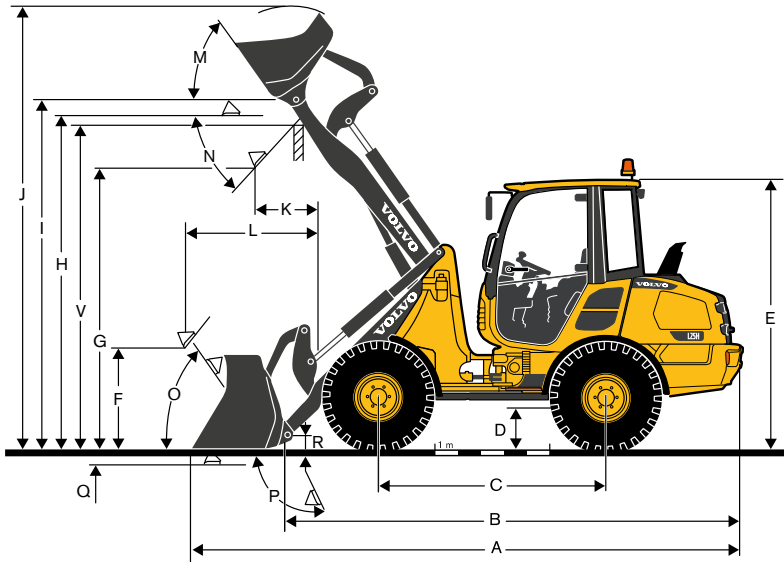

SPECIFICATIONS ACCORDING TO BUCKET TYPE

Description	Unit	L20H							
		General Purpose		Light Material		4-in-1			
with 335/80 R18 tires									
Capacity heaped	m ³ yd ³	0.7	0.9	0.85	1.11	1.0	1.3	0.65	0.85
Material density	kg/m ³ lb/yd ³	1,900	3,203	1,700	2,865	1,400	2,360	1,900	3,203
Static tipping load, straight (ISO / DIS)	kg lb	3,350	7,385	3,300	7,275	3,250	7,165	3,050	6,724
Static tipping load, full turn 38° (ISO / DIS)	kg lb	3,000	6,614	2,950	6,504	2,900	6,393	2,750	6,063
Hydraulic lifting capacity, max.	kN lbf	35	7,868	34	7,644	33.5	7,531	32.5	7,306
Breakout force	kN lbf	35	7,868	30.5	6,857	28	6,295	36.5	8,206
A Total length	mm ft in	5,035	16'6"	5,135	16'10"	5,195	17'1"	5,030	16'6"
J Lift height, max.	mm ft in	4,065	13'4"	4,145	13'7"	4,195	13'9"	4,070	13'4"
S Bucket width	mm ft in	1,650	5'5"	1,650	5'5"	1,800	5'11"	1,650	5'5"
a ₁ Clearance circle	mm ft in	8,205	26'11"	8,260	27'1"	8,435	27'8"	8,205	26'11"
Q Digging depth	mm ft in	105	0'4"	105	0'4"	105	0'4"	145	0'6"
G Dump height	mm ft in	2,520	8'3"	2,445	8'0"	2,405	7'11"	2,500	8'2"
K Reach at max. height	mm ft in	640	2'1"	705	2'4"	745	2'5"	555	1'10"
L Reach, max.	mm ft in	1,455	4'9"	1,520	4'12"	1,560	5'1"	1,370	4'6"
Operating weight	kg lb	4,480	9,877	4,500	9,921	4,520	9,965	4,650	10,251

DIMENSIONS

L20H parallel linkage with 335/80 R18 tires and ISO-type coupler

Description	Unit		
B	mm ft in	4,275	14'0"
C	mm ft in	2,050	6'9"
D	mm ft in	290	0'11"
E	mm ft in	2,485	8'2"
F	mm ft in	884	2'11"
H	mm ft in	2,990	9'10"
I	mm ft in	3,140	10'4"
M	°	56	
N	°	45	
O	°	54	
P	°	65	
R	mm ft in	145	0'6"
T	mm ft in	1,300	4'3"
U	mm ft in	1,630	5'4"
V	mm ft in	2,905	9'6"
a ₂	mm ft in	3,830	12'7"
a ₃	mm ft in	2,155	7'1"
a ₄	°	± 38	

LOADING FORKS SPECIFICATIONS

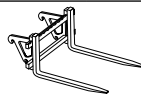

Description	Unit		L20H	
With Loading Fork Centre of gravity	mm	ft in	500	1'8"
Tipping load, full turn (ISO / DIS)	kg	lb	2,290	5,050
Payload according to EN 474-3, 60/80%	kg	lb	1,350/1,800	2,980/3,970
Payload 80%, transport position, 40 ° full turn	kg	lb	2,200	4,850

Equipment

STANDARD AND OPTIONAL EQUIPMENT

- = Standard
- = Optional

Engine

Diesel engine, watercooled, with Diesel Oxidation Catalyst (DOC)	•
Automatic engine shut down	○
Hand throttle	•
Extra fuel filter with water separator	○
Fuel pre-heater (12 Volt)	○
Cold start aid with grid heater (110/220 Volt)	○
Two stage air filter with primary filter and safety element	•
Pre cleaner air filter (Turbo II)	○
Safety start	•

Drivetrain

Hydrostatic drive	•
Combined Brake/Inch pedal	•
Operator-selected 100% differential locks in both axles	•
Hand control inch valve	○
Driveline shut off (via parking brake)	○
Driveline shut off (via parking brake and seat belt)	○

Electrical System

Halogen front headlights with high and low beams and integrated parking lights	•
Brake and rear lights, turn signals with hazard lights	•
Working light (rear right)	•
Working lights(2 front/2 rear), Halogen	○
Working lights (2 front/2 rear), LED	○
Power outlet 12Volt/20Ampere (for fuel filling pump)	○
CareTrack Basic	○
CareTrack Advanced	○

Hydraulic system

Separate gear- pump-section for working and steering hydraulic	•
Control valve with three-spool system	•
Additional hydraulic pump (high flow)	○
Single lever with integrated 3rd function	○
Flow sharing valve	○
Boom suspension system (BSS)	○
Additional couplings for 3rd hydraulic circuit	○
Additional 4th hydraulic circuit including couplings	○

Environmental

Biodegradable hydraulic oils	○
------------------------------	---

Instrumentation & controls

Single lever control with Working hydraulic functions boom and bucket	•
Single lever control with Float function	•
Single lever control with Forward/reverse/neutral	•
Single lever control with Differential lock	•
Single lever control with Speed range low/high	•
Single lever control with 3rd hydraulic function	•
Single lever control with Horn	•
Single lever control with Hazard warning switch	•
Analogue indicator for Fuel level	•
Analogue indicator for Hydraulic oil temperature	•
Illuminated symbols (colour-coded) for Operating hours	•
Illuminated symbols (colour-coded) for Direction (forward/reverse)	•
Illuminated symbols (colour-coded) for Turn signal (left/right)	•
Illuminated symbols (colour-coded) for Grid heater (option)	○
Illuminated symbols (colour-coded) for Headlights	•
Illuminated symbols (colour-coded) for Differential locks	•
Illuminated symbols (colour-coded) for Battery charging	•
Illuminated symbols (colour-coded) for Travel speed (low/high)	•
Illuminated warning symbols with acoustic signal (with ignition on) for coolant temperature, hydraulic oil temperature, hydraulic oil filter, engine oil pressure, air filter restriction, alternator, parking brake	•

STANDARD AND OPTIONAL EQUIPMENT

- = Standard
- = Optional

Safety and security

Rotating beacon, Halogen	○
Rotating beacon, LED	○
Audible reverse alarm	○
Audible reverse alarm, switchable	○
Audible reverse alarm, smooth sound	○
Anti-theft system	○
Safety valves for lifting	○
Safety valves for tilting	○
Wheel block	○
Warning Triangle	○
Protective guards for Main head lights	○
Protective guards for Working lights	○
Protective guards for Rear lights	○

Cab, Exterior

ROPS/FOPS-cab isolation mounted	•
Lockable door	•
All-round tinted tempered glass	•
Laminated windscreen	•
Cab door latching when open (within machine width)	•
Window right hand side openable and lockable at 180° (within machine width)	•
Windscreen wiper with washer (front/rear)	•
External rear view mirrors (right/left)	•
External rear view mirrors (right/left), heated	○
External rear view mirrors (right/left), enhanced	○

Cab, Interior

Cab light	•
12 Volt accessories socket	•
Mechanic-suspension driver's seat with hand wheel for weight adjustment, integrated 2-point belt system, height and tilt adjustment, horizontal adjustment and backrest adjustment	•
Air-suspension and heated driver's seat with automatic weight adjustment, 12 Volt, pneumatic height adjustment, back rest adjustment, horizontal and tilt adjustment, adjustable shock absorber, seat cushion adjustment, pneumatic lumbar support and quick release	○
Seat belt	•
Sunvisor	•
Heater with air-filter and defroster (front/rear)	•
Cab ventilation	•
Storage box	•
Air conditioning (AC)	○
Radio	○
Preparation for radio	○

Working Equipment

Bucket Level Indicator mechanical	○
Sweeper preparation (switch inside cab, 7 pin electrical socket on boom)	○

STANDARD AND OPTIONAL EQUIPMENT

• = Standard

o = Optional

Carriage Body

Fenders (front/rear)	•
Lockable engine hood	•
Vertical exhaust pipe	•
Towing device	•
Lifting eyes	•
Tying down eyes	•

Service and maintenance

Tool kit (tools and grease gun)	•
Document box	o

Other

ISO-type coupler	o
Universal Attachment Bracket (SSL)	•
Customized machine colour	o

Official approval

Quality: DIN/ISO 9001	•
Safety: CE - Criteron	•
Machine guide-lines 2006/42/EC	•
ROPS ISO 3471	•
FOPS ISO 3449	•
Operating weight: ISO 7131	•
Tipping load / Payload: ISO 14397-1	•
EMC (Electromagnetic Compatibility)	•
89/336/EEC plus supplement	•
Environment: DIN/ISO 14001	•
Sound regulation: 2000/14/EC	•

V O L V O