

VOLVO DOUBLE DRUM COMPACTORS

DD100

10t 97kW



THE VERSATILITY TO SMOOTHLY DO IT ALL.



The Volvo DD100 is your versatile performer, providing flexibility to handle varying conditions, widths and applications, from roadways and large parking lots to airport runways. It's the 10-ton double drum asphalt compactor that gives you complete control in choice of amplitudes, frequency and more. The result is a smooth, finished mat achieved with less passes and more profitability.



Selectable eight amplitudes

Eight amplitude settings can be easily adjusted by the operator, allowing for frequent changes as application conditions vary. If conditions warrant an increase in dynamic drum force, changing drum amplitude results in fewer passes and increased productivity. Improves versatility and finishing work quality.



Frequency selections

Operator can easily select between eccentric frequencies from the operator's electronic vibration control. Allows the matching of machine performance to production requirements. Improves finished product quality and profitability.

Variable water flow control

Allows the operator to infinitely and variably adjust water flow required to prevent asphalt sticking to the drum. Using the minimal effective amount saves water usage, decreasing downtime as a result of water refills. Improves finished product. Conserves water.



Automatic eccentric rotation

Eccentric rotation automatically matches the direction of travel, improving mat smoothness with less material distortion. Uses less engine power. Allows the operator to concentrate on other operational responsibilities, eliminating the possibility of neglecting to change the eccentric rotation.



Impact spacing meter

Allows the operator to easily monitor the machine's impact spacing with a control panel-mounted meter. Permits adjustments for travel speed allowing the maintenance of the proper impact spacing needed for asphalt smoothness. Improves finished product quality.



Isolated operator's platform

The operator's platform is rubber isolated to reduce the effect machine vibrations have on the operator. Decreases fatigue for greater operator comfort, safety and prolonged productivity.

SEE MORE. DO MORE.

5-position rotating console

Operator's console can be rotated in 5 positions allowing maximum comfort and sight line visibility for enhanced maneuverability.

Variable water flow control

Adjustable water flow to prevent asphalt sticking to the drum. Saves water usage and decreases downtime due to water refills.



Isolated operator's platform

The operator's platform is rubber isolated to reduce the effect machine vibrations have on the operator. Decreases fatigue for greater operator comfort, safety and prolonged productivity.



Frequency selections

Easily select eccentric frequencies from the operator's electronic vibration control, allowing the matching of machine performance to production requirements.

ROPS/FOPS safety

Provides peace of mind and safety by protecting the operator in the event of machine roll over and/or overhead falling objects.

Automatic vibration

Vibration automatically engages or disengages when an operator-selected upper and lower respective travel speed threshold has been reached.



Vandalism protection

Lockable vandal covers protect the console, while lockable engine hoods, fuel cap, water fill cap and deck access doors deter theft and vandalism.

Powerful, efficient engine

Cummins Tier 3/Stage III engine delivers plenty of power, performance and environmental emission compliance.



Selectable eight amplitudes

Easy operator adjustments allow for frequent changes as application conditions vary, improving versatility.



Automatic eccentric rotation

Automatically matches the direction of travel, for improved mat smoothness, less material distortion and use of less engine power.



Impact spacing meter

Easy monitoring of the impact spacing permits travel speed adjustments that help maintain proper asphalt smoothness.

Superior drum spray system

Pressurized water system provides a consistent water flow to the drum surfaces, eliminating possible asphalt material buildup that can require rework.

YOUR ACCESS TO MORE.

Your local Volvo dealer is always there for you. Volvo backs each and every machine with the most knowledgeable people in the industry. We have the solutions to keep you up, running and earning. Strong, dependable equipment. Trusted industry experience. Reliable, genuine Volvo parts and expert service support. Solutions for all your jobs.



Service & maintenance access

The swing-up hood design provides easy, complete access to the engine and hydraulic components, allowing inspections and maintenance to be performed more efficiently. Unobstructed daily checkpoints with ground-level access to the engine, radiator, battery and filters saves time and helps ensure daily maintenance is properly completed.

Dealer support comes standard

Your local Volvo dealer backs you and your operation with a ready supply of genuine Volvo parts that are perfectly matched to your machine. Your dealer is also ready to help you stay working with expert, trained service and support. With solutions for all your jobs, Volvo helps you improve your owning and operating costs.



Machine Weight (w/ ROPS)		
Operating Weight	kg	10 025
Static Weight @ Front Drum	kg	5 200
Static Weight @ Rear Drum	kg	4 825
Shipping Weight	kg	9 338

Drums		
Width	mm	1 676
Diameter	mm	1 219
Shell Thickness (nominal)	mm	19
Finish	Machined surface; chamfered & radiused edges	

Vibration		
Frequency	Hz	41,7 / 30,8
Amplitude	mm	0,41 – 1,01
Centrifugal Force Range	kN	63,0 – 116,0
Amplitude Settings		8

Propulsion		
Type	Closed-loop hydrostatic, parallel circuit to both drums	
Drum Drive	Heavy-duty radial piston motors	
Travel Speed	km/h	0 – 11,4

Engine		
Make / Model	Cummins QSB 4.5, Tier 3	
Engine Type	Turbocharged 4-cylinder	
Rated Power @ Installed Speed	kW	96,9

Electric		
DC, negative ground	Volt	12
Alternator	A	95
Battery (2 absorbed electrolytic)	CCA	800

Brakes		
Service	Dynamic hydrostatic through propulsion system	
Parking / Secondary	SAHR on front-drum & rear-drum drive motors	

Water System		
Type	Pressure spray drum wetting system with LDPE water tanks	
Pumps	Diaphragm water pumps, primary & secondary for each drum	
Spray Bars	Primary & secondary spray bars for each drum	
Nozzles	Hand-serviceable fan spray nozzles; 7 main, 6 auxiliary per spray bar	
Filtration	Basket strainer each tank, water filter each pump, fine filter each nozzle	
Drum Wipers	Rubber wiper for each drum	
Water Tank Capacity	492 l each tank	

Miscellaneous		
Articulation Angle (center pivot steering) (plus/minus)	°	40
Oscillation Angle (plus/minus)	°	10
Inside Turning Radius (to drum edge)	mm	3 558
Fuel Capacity	l	189
Hydraulic Oil Capacity	l	133
Gradeability (theoretical)	%	24,5

Product improvement is a continuing goal at Volvo. Designs and specifications are subject to change without notice or obligation.

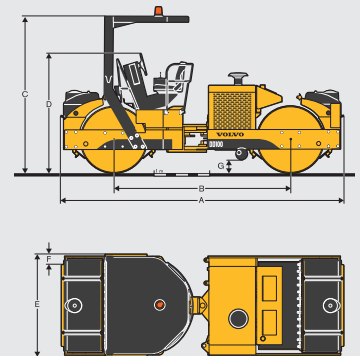

DIMENSIONS		
A Overall Length	mm	5 086
B Drum Base	mm	3 200
C Overall Height (top of ROPS / FOPS)	mm	2 845
D Overall Height (top of steering wheel)	mm	2 210
E Overall Width	mm	1 910
F Side Clearance	mm	117,5
G Curb Clearance	mm	430



Nine selectable frequencies

VOLVO CONSTRUCTION EQUIPMENT



Volvo Construction Equipment is different. Our machines are designed, built and supported in a different way. That difference comes from an engineering heritage of over 175 years. A heritage of thinking first about the people who actually use the machines. About how to help them be safer, more comfortable, more productive. About the environment we all share. The result of that thinking is a growing range of machines and a global support network dedicated to helping you do more. People around the world are proud to use Volvo. And we're proud of what makes Volvo different.

Not all products are available in all markets. Under our policy of continuous improvement, we reserve the right to change specifications and design without prior notice. The illustrations do not necessarily show the standard version of the machine.

VOLVO

Volvo Construction Equipment
www.volvoce.com

Ref. No 20025565-A
2011.05
Volvo, Global Marketing

English-A8
COA