

VOLVO EXCAVATOR

EC240B PRIME

24.4 – 25.7 t, 185 metric hp



MORE CARE. BUILT IN.



TAKE A TOUR. EXPERIENCE THE EC240B PRIME.

MORE SAFETY

- **Safety** is a **core value** at Volvo and it shows in our machine.
- **Anti-slip steps and platforms** with punched steel plates for superior grip even when wet or icy.
- **Low engine emission levels and low noise.**
- **Tumbler length** ensures stability.
- **Recessed bolts on superstructure** walk areas for less risk of trip hazard.
- **Lead-free exterior paint** is in harmony with the environment.

MORE PROFIT

- **Powerful, innovative and efficient Volvo engine:** well-matched to hydraulic system, components and design.
- Volvo continues to deliver **industry-leading fuel efficiency.**
- **Advanced hydraulic system** with priority functions and optional float position.
- **Optional hydraulic quick fit** increases versatility.





MORE COMFORT

- **Large and comfortable cab** puts you in command with ergonomic controls.
- **Roomy, adjustable seat** supports your whole body.
- **Top-mounted windshield wiper** cleans a wider area – including both upper corners.
- **Vibration dampening** protects against whole body fatigue for all-day productivity.
- **Electronic climate control system** delivers the highest-capacity heating and cooling available.

MORE UPTIME

- **Simplified, ground level serviceability** means more uptime.
- **Easy access, centralized lubrication points.**
- **Easy to learn. Easy to operate. Easy to get more done.**

MORE QUALITY

- **Strengthened undercarriage frame** endures daily use.
- **Reinforced boom/arm and proven components** deliver every time.
- **Reinforced superstructure** with double welded corners.
- **Greased and sealed track link** guarantees long life.

VOLVO - A PARTNER TO TRUST.

Most days you work by yourself in your machine. When you're in the Volvo EC240B prime Excavator, you are not alone. You've got a partner you can trust, backed by your local Volvo dealer and everything else that comes with the Volvo name. That means reliability, quality and a partner that will work as hard to keep you profitable as it did to earn your trust. With the Volvo EC240B prime, it also means industry-leading fuel economy, the best in comfort and legendary safety. Your new partner will help you take on the big jobs, excelling in land clearing, landfills, road building, pipe laying and more.

Volvo: your global, local partner

Since 1927, Volvo has earned a global reputation for providing complete solutions. Volvo is built on core values of quality, safety and environmental care. The extensive line of construction equipment is augmented by Volvo's commercial transport solutions, including buses and trucks. This global experience and expertise have led to the ongoing development of engines with the lowest fuel consumption in their class. Today, the tradition continues with Volvo B prime-Series Excavators — designed and built to the exacting standards that make each machine a trusted Volvo partner.

Endurance through quality

Quality. It's what you should expect from Volvo, and it's built in throughout the Volvo EC240B prime. Experience the Volvo difference, from the well-built cab details to the reinforced service doors to the rigid, long-life undercarriage.

If you have ever operated a Volvo Wheel Loader, Articulated Hauler or any of our machines, you know that Volvo is your edge for production, comfort and safety. Rely on the Volvo EC240B prime Excavator — every day.

Strength, protection, durability

The Volvo EC240B prime's proven, long life booms and arms are ready for tough jobs and tough conditions. We've designed it and tested it to deliver strength and day after day dependability. Count on Volvo to help your business grow with the capability you need.

Leading fuel efficiency is your edge

One of the best ways to cut costs and increase profit is through fuel efficiency — and the EC240B prime is set to remain the industry leader that gets the most out of each tank. Volvo: your most fuel-efficient option.

Our experience - your work

The Volvo EC240B prime Excavator is made for your work. From fast, 25-ton hauler loading and land clearing to civil engineering, landfill work and residential road building, the Volvo EC240B prime puts you in command.

The innovators of comfort

Volvo has a reputation for innovation in comfort, helping customers get more done through less fatigue. The EC240B prime improves on Volvo innovation with a larger, more ergonomic work environment. Visibility is better. So are the seat, floor space and access to controls/switches.





VOLVO'S ENGINE LEADERSHIP SPANS LAND, SEA, SKY AND SPACE

As the world's second largest manufacturer of 9-to-18-liter diesel engines, Volvo has unmatched expertise designing power systems that move the world. Volvo engines for Volvo Construction Equipment, Volvo

Aero, Volvo Buses, Volvo Penta and Volvo Trucks define productivity and fuel economy. Our performance has been honed on land, over the sea, across the sky and into space. Leading research and development

keeps all Volvo Group products at the forefront of productivity. So when we say Volvo engines are tested — and proven — you can believe it. Trust in it. It's the real advantage of Volvo Power.

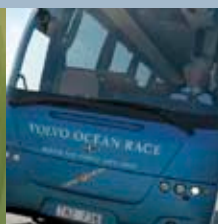
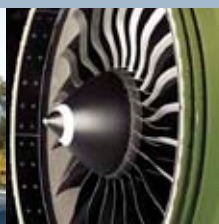

BUILT TO RUN – SUPPORTED FOR LIFE.

Even the best machines need service and maintenance to be as productive tomorrow as they are today. With superior attention to detail, we've created a productivity chain of machines, parts and service. Our global Customer Support organization delivers the values you've come to expect from Volvo Construction Equipment.

We care about your operation – anywhere, anytime

Volvo Construction Equipment comes with a professional Customer Support organization providing genuine parts, aftersale service and training — providing you with controlled owning and operation costs. With all the products and resources at our disposal, we can offer you the best support there is. Anywhere, anytime.

Four levels of support, one level of care

The best way to get the most out of your Volvo is to invest in a Volvo Customer Support Agreement. Since business' needs vary, we've made it easy for you to select the agreement that's right for your business by creating four levels of Customer Support Agreements. We offer programs that provide everything from regular machine inspections to a comprehensive repair and maintenance program that takes the hassle and worry out of running a workshop and gives you total peace of mind.

CareTrack – fast and correct information

CareTrack is an optional GPS monitoring program that works with the machine's diagnostic system. Installation is simple. You and your dealer can remotely track usage, productivity, fuel consumption and more. Maximize uptime through important service reminders. CareTrack also monitors geographic machine location and can even prevent unauthorized use. With CareTrack, you can focus on the care of your business while your Volvo dealer focuses on the care of your machine.

MATRIS reports on your efficiency

MATRIS delivers detailed operating history analysis about the utilization and efficiency factors that influence your operating costs. MATRIS turns the data captured inside the machine's computer into easy-to-use graphs and reports. Maximize machine and operator performance, while reducing maintenance costs and increasing service life.

PROSIS makes parts ordering faster

PROSIS is a CD-ROM application that makes it quick and easy for your Volvo dealer to order all your Volvo CE product parts. Your dealer will help you find the right part, place your order and get you back up and running fast.

Standard and optional equipment may vary by market. Please consult your local Volvo dealer for details.

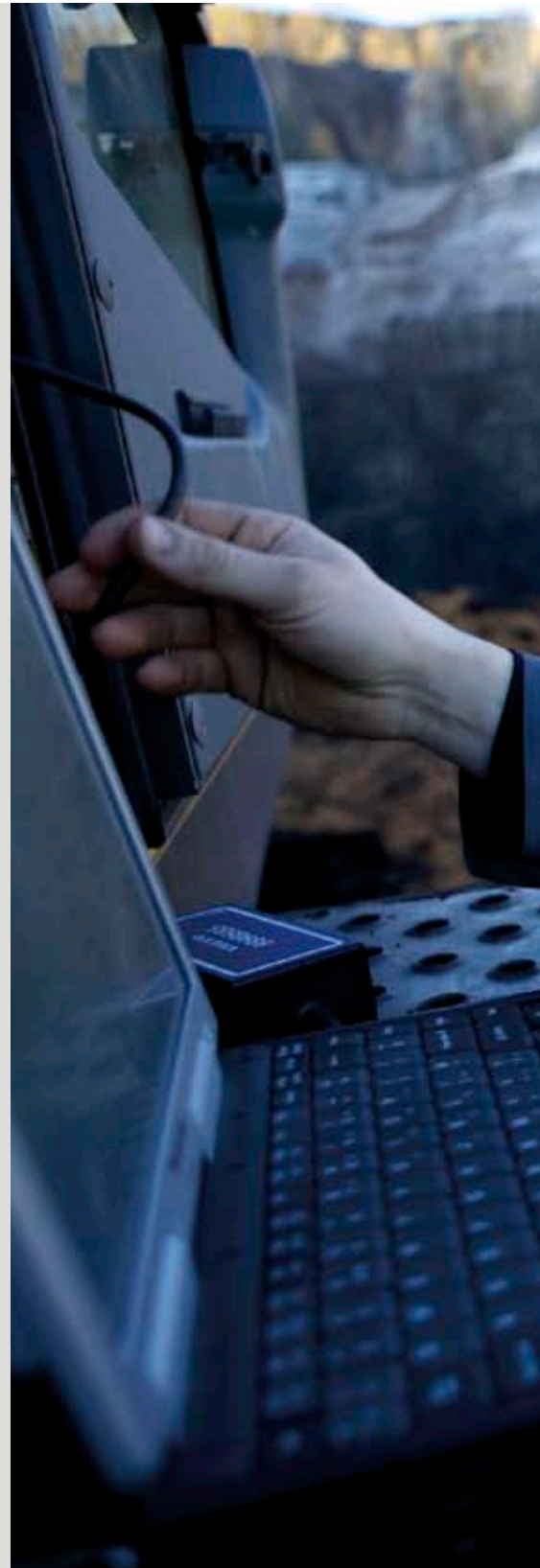



SPECIFICATIONS

Engine

The new Volvo diesel engine delivers lower emissions, superior performance and fuel efficiency. The engine uses precise, high-pressure fuel injectors turbo charger and electronic engine controls to optimize machine performance.

Automatic Idling System: Reduces engine speed to idle when the levers and pedals are not activated resulting in less fuel consumption and low cab noise levels.

Engine	Volvo D7E EBE2
Power output at	33.3 r/s (2,000 rpm)
Net (ISO 9249/SAE J1349)	130 kW (174 metric hp)
Gross (SAE J1995)	138 kW (185 metric hp)
Max. torque at 1,350 rpm	870 Nm
No. of cylinders	6
Displacement	7.1 l
Bore	108 mm
Stroke	130 mm

Electrical system

High-capacity electrical system that is well protected. Waterproof double-lock harness plugs are used to secure corrosion-free connections. The main relays and solenoid valves are shielded to prevent damage.

Contronics: provides advanced monitoring of machine functions and important diagnostic information.

Voltage	24 V
Batteries	2 x 12 V
Battery capacity	200 Ah
Alternator	28 V/80 A

Service refill capacities

Fuel tank	380 l
Hydraulic system, total	320 l
Hydraulic tank	190 l
Engine oil	30 l
Engine coolant	36 l
Swing reduction unit	5.9 l
Travel reduction unit	2 x 5.2 l

Swing system

The superstructure is swung by the means of an axial piston motor and a planetary reduction gear. Automatic swing holding brake and anti-rebound valve are standard.

Max. swing speed	11.3 rpm
Swing torque	8,855 kg·m

Drive

Each track is powered by an automatic two-speed shift travel motor. The track brakes are multi-disc, spring-applied and hydraulic released. The travel motor, brake and planetary gears are well protected within the track frame.

Max. tractive effort	208.9 kN (21,300 kg)
Max. travel speed	3.3/5.5 km/h
Gradeability	35° (70%)

Undercarriage

The undercarriage has a robust X-shaped frame. Greased and sealed track chains are standard.

No. of track pads	2 x 51
Link pitch	190 mm
Shoe width, triple grouser	
LC prime/NLC prime	600/700/800/900 mm
LR prime	600/800/900 mm
Shoe width, double grouser	
LC prime	700 mm
No. of bottom rollers	2 x 9
No. of top rollers	2 x 2

Hydraulic system

The hydraulic system, also known as the Integrated work mode control is designed for high-productivity, high-digging capacity, high-maneuvering precision and good fuel economy. The summation system, boom, arm and swing priority along with boom and arm regeneration provide optimum performance.

The following important functions are included in the system:

Summation system: Combines the flow of both hydraulic pumps to ensure quick cycle times and high productivity.

Boom priority: Gives priority to the boom operation for faster raising when loading or performing deep excavations.

Arm priority: Gives priority to the arm operation for faster cycle times in leveling and for increased bucket filling when digging.

Swing priority: Gives priority to swing functions for faster simultaneous operations.

Regeneration system: Prevents cavitation and provides flow to other movements during simultaneous operations for maximum productivity.

Power boost: All digging and lifting forces are increased.

Holding valves: Boom and arm holding valves prevent the digging equipment from creeping.

Main pump

Type	2 x variable displacement axial piston pumps
Maximum flow	2 x 230 l/min

Pilot pump

Type	Gear pump
Maximum flow	1 x 20 l/min

Hydraulic motors

Travel	Variable displacement axial piston motor with mechanical brake
Swing	Fixed displacement axial piston motor with mechanical brake

Relief valve setting

Implement	32.4/34.3 Mpa (330/350 kg/cm ²)
Travel system	34.3 Mpa (350 kg/cm ²)
Swing system	26.5 Mpa (270 kg/cm ²)
Pilot system	3.9 Mpa (40 kg/cm ²)

Hydraulic cylinders

Boom	2
Bore x Stroke	ø140 x 1,480 mm
Arm	1
Bore x Stroke	ø150 x 1,745 mm
Bucket	1
Bore x Stroke	ø140 x 1,140 mm

Cab

The operator's cab has easy access via a wide door opening. The cab is supported on hydraulic dampening mounts to reduce shock and vibration levels. These along with sound absorbing lining provide low noise levels. The cab has excellent all-round visibility. The front windshield can easily slide up into the ceiling and the lower front glass can be removed and stored in the side door.

Integrated air conditioning and heating system:

The pressurized and filtered cab air is supplied by an automatically controlled fan. The air is distributed throughout the cab from 13 vents.

Ergonomic operator's seat: The adjustable seat and joystick console move independently to accommodate the operator. The seat has nine different adjustments plus a seat belt for the operator's comfort and safety.

Sound level in cab	LpA 73 dB(A)
External sound level	LwA 106 dB(A)

Ground pressure

- **EC240B LC prime with** 6.0 m boom, 2.97 m arm, 1,100 l (975 kg) bucket and 4,600 kg counterweight.

Description	Shoe width	Operating weight up to	Ground pressure	Overall width
Triple grouser	600 mm	24,425 kg	49.2 kPa (0.49 kg/cm ²)	3,190 mm
	700 mm	24,726 kg	42.7 kPa (0.43 kg/cm ²)	3,290 mm
	800 mm	25,023 kg	37.8 kPa (0.38 kg/cm ²)	3,390 mm
	900 mm	25,328 kg	34.0 kPa (0.34 kg/cm ²)	3,490 mm
Double grouser	700 mm	25,002 kg	43.2 kPa (0.43 kg/cm ²)	3,290 mm

- **EC240B LC prime with** 6.0 m boom, 2.97 m arm, 1,100 l (975 kg) bucket and 5,300 kg counterweight.

Description	Shoe width	Operating weight up to	Ground pressure	Overall width
Triple grouser	600 mm	25,119 kg	50.6 kPa (0.51 kg/cm ²)	3,190 mm
	700 mm	25,420 kg	43.9 kPa (0.44 kg/cm ²)	3,290 mm
	800 mm	25,718 kg	38.9 kPa (0.39 kg/cm ²)	3,390 mm
	900 mm	26,023 kg	35.0 kPa (0.35 kg/cm ²)	3,490 mm
Double grouser	700 mm	25,697 kg	44.4 kPa (0.44 kg/cm ²)	3,290 mm

- **EC240B NLC prime with** 6.0 m boom, 2.97 m arm, 1,100 l (820 kg) bucket and 5,300 kg counterweight.

Description	Shoe width	Operating weight up to	Ground pressure	Overall width
Triple grouser	600 mm	25,053 kg	50.5 kPa (0.50 kg/cm ²)	2,990 mm
	700 mm	25,354 kg	43.8 kPa (0.44 kg/cm ²)	3,090 mm
	800 mm	25,651 kg	38.8 kPa (0.39 kg/cm ²)	3,190 mm
	900 mm	25,956 kg	34.9 kPa (0.35 kg/cm ²)	3,290 mm

- **EC240B LR prime with** 10.2 m boom, 7.85 m arm, 520 l (820 kg) bucket and 6,600 kg counterweight.

Description	Shoe width	Operating weight up to	Ground pressure	Overall width
Triple grouser	600 mm	26,988 kg	54.4 kPa (0.54 kg/cm ²)	2,990 mm
	800 mm	27,586 kg	41.7 kPa (0.42 kg/cm ²)	3,190 mm
	900 mm	27,892 kg	37.5 kPa (0.37 kg/cm ²)	3,290 mm

Max. permitted buckets

- Notes: 1. Bucket size based on ISO 7451, heaped material with a 1:1 angle of repose.
 2. "Max. permitted sizes" are for reference only and are not necessarily available from the factory.
 3. Bucket widths are less than bucket's tip radius.

- **EC240B LC prime with direct fit bucket**, 5,300 kg counterweight.

Description	Max. bucket volume / weight	6.0 m boom		
		2.5 m arm	2.97 m arm	3.6 m arm
GP bucket 1.5 t/m ³	l / kg	1,825/1,550	1,650/1,400	1,450/1,225
GP bucket 1.8 t/m ³	l / kg	1,600/1,375	1,450/1,250	1,300/1,100
HD bucket 1.8 t/m ³	l / kg	1,525/1,525	1,375/1,375	1,225/1,225
HD bucket 2.0 t/m ³	l / kg	1,425/1,425	1,300/1,300	1,150/1,150

- **EC240B LC prime with S1 quick fit bucket**, 5,300 kg counterweight.

Description	Max. bucket volume / weight	6.0 m boom		
		2.5 m arm	2.97 m arm	3.6 m arm
GP bucket 1.5 t/m ³	l / kg	1,700/1,450	1,525/1,300	1,325/1,125
GP bucket 1.8 t/m ³	l / kg	1,500/1,275	1,350/1,150	1,175/1,000
HD bucket 1.8 t/m ³	l / kg	1,425/1,425	1,275/1,275	1,125/1,125
HD bucket 2.0 t/m ³	l / kg	1,325/1,325	1,200/1,200	1,050/1,050

- **EC240B LC prime with U quick fit bucket**, 5,300 kg counterweight.

Description	Max. bucket volume / weight	6.0 m boom		
		2.5 m arm	2.97 m arm	3.6 m arm
GP bucket 1.5 t/m ³	l / kg	1,600/1,375	1,450/1,225	1,250/1,050
GP bucket 1.8 t/m ³	l / kg	1,425/1,200	1,275/1,075	1,100/925
HD bucket 1.8 t/m ³	l / kg	1,350/1,350	1,200/1,200	1,050/1,050
HD bucket 2.0 t/m ³	l / kg	1,250/1,250	1,125/1,125	975/975

- EC240B NLC prime with direct fit bucket, 5,300 kg counterweight.

Description	Max. bucket volume / weight	6.0 m boom		
		2.5 m arm	2.97 m arm	3.6 m arm
GP bucket 1.5 t/m ³	l / kg	1,675/1,425	1,550/1,325	1,425/1,225
GP bucket 1.8 t/m ³	l / kg	1,475/1,250	1,375/1,175	1,275/1,075
HD bucket 1.8 t/m ³	l / kg	1,400/1,400	1,300/1,300	1,200/1,200
HD bucket 2.0 t/m ³	l / kg	1,300/1,300	1,225/1,225	1,125/1,125

- EC240B NLC prime with S1 quick fit bucket, 5,300 kg counterweight.

Description	Max. bucket volume / weight	6.0 m boom		
		2.5 m arm	2.97 m arm	3.6 m arm
GP bucket 1.5 t/m ³	l / kg	1,550/1,325	1,450/1,225	1,325/1,125
GP bucket 1.8 t/m ³	l / kg	1,375/1,175	1,275/1,075	1,175/1,000
HD bucket 1.8 t/m ³	l / kg	1,300/1,300	1,200/1,200	1,100/1,100
HD bucket 2.0 t/m ³	l / kg	1,200/1,200	1,125/1,125	1,025/1,025

- EC240B NLC prime with U quick fit bucket, 5,300 kg counterweight.

Description	Max. bucket volume / weight	6.0 m boom		
		2.5 m arm	2.97 m arm	3.6 m arm
GP bucket 1.5 t/m ³	l / kg	1,325/1,125	1,200/1,025	1,075/925
GP bucket 1.8 t/m ³	l / kg	1,175/1,000	1,075/900	950/800
HD bucket 1.8 t/m ³	l / kg	1,100/1,100	1,025/1,025	900/900
HD bucket 2.0 t/m ³	l / kg	1,025/1,025	950/950	850/850

Dimensions

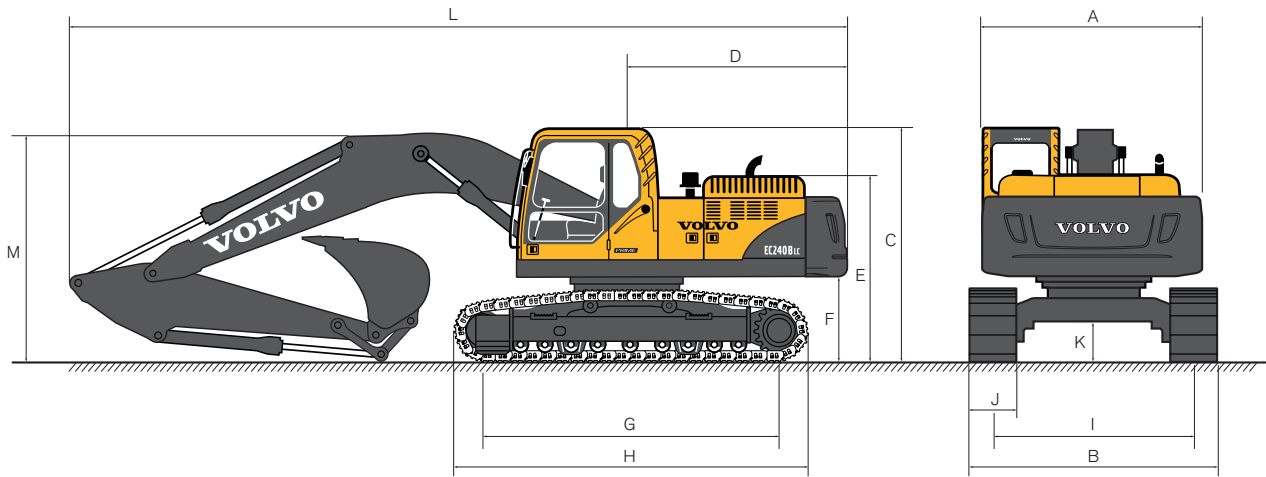

Description	Unit	EC240B LC prime		
		6.0 m boom		
		2.5 m arm	2.97 m arm	3.6 m arm
A. Overall width of superstructure	mm	2,890	2,890	2,890
B. Overall width	mm	3,190	3,190	3,190
C. Overall height of cab	mm	2,990	2,990	2,990
D. Tail swing radius	mm	2,940	2,940	2,940
E. Overall height of engine hood	mm	2,370	2,370	2,370
F. Counterweight clearance *	mm	1,080	1,080	1,080
G. Tumbler length	mm	3,850	3,850	3,850
H. Track length	mm	4,650	4,650	4,650
I. Track gauge	mm	2,590	2,590	2,590
J. Shoe width	mm	600	600	600
K. Min. ground clearance *	mm	470	470	470
L. Overall length	mm	10,220	10,130	10,195
M. Overall height of boom	mm	3,220	3,040	3,220

* Without shoe grouser

Description	Unit	EC240B NLC prime			EC240B LR prime
		6.0 m boom			10.2 m boom
		2.5 m arm	2.97 m arm	3.6 m arm	7.85 m arm
A. Overall width of superstructure	mm	2,890	2,890	2,890	2,890
B. Overall width	mm	2,990	2,990	2,990	3,390
C. Overall height of cab	mm	3,030	3,030	3,030	3,030
D. Tail swing radius	mm	2,940	2,940	2,940	2,960
E. Overall height of engine hood	mm	2,370	2,370	2,370	2,370
F. Counterweight clearance *	mm	1,080	1,080	1,080	1,080
G. Tumbler length	mm	3,850	3,850	3,850	3,850
H. Track length	mm	4,650	4,650	4,650	4,650
I. Track gauge	mm	2,390	2,390	2,390	2,590
J. Shoe width	mm	600	600	600	800
K. Min. ground clearance *	mm	470	470	470	480
L. Overall length	mm	10,220	10,130	10,195	14,470
M. Overall height of boom	mm	3,220	3,040	3,220	3,170

* Without shoe grouser

• Boom

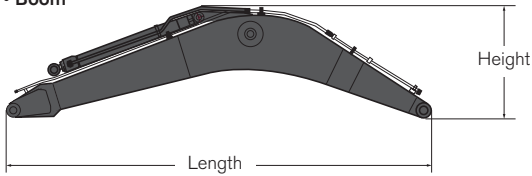

Description	Unit	EC240B LC prime/EC240B NLC prime		EC240B LR prime
		6.0 m	6.0 m HD	10.2 m
Length	mm	6,210	6,210	10,410
Height	mm	1,630	1,630	1,550
Width	mm	770	770	726
Weight	kg	2,600	2,710	2,820

* Includes cylinder, pin and piping

• Arm

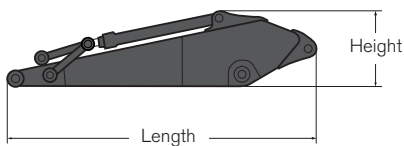

Description	Unit	EC240B LC prime/EC240B NLC prime				EC240B LR prime
		2.5 m	2.97 m	2.97 m HD	3.6 m	7.85 m
Length	mm	3,590	4,060	4,060	4,730	8,970
Height	mm	930	920	920	920	1,145
Width	mm	480	480	480	480	382
Weight	kg	1,027	1,045	1,120	1,160	1,520

* Includes cylinder, piping and linkage

Working ranges & digging forces

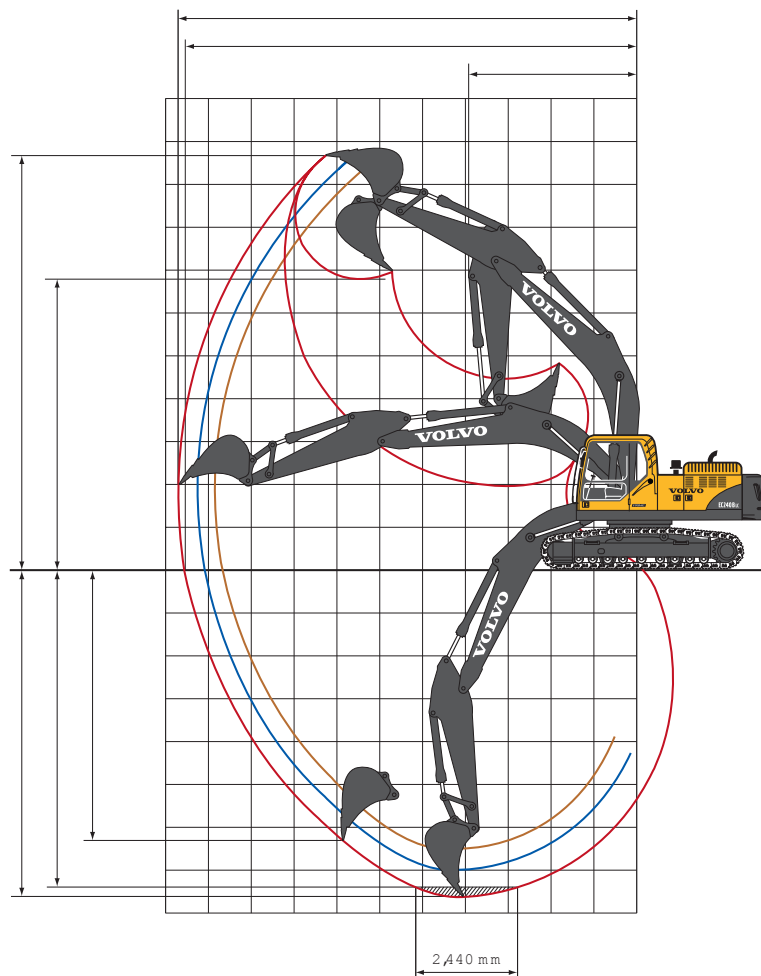

Machine with direct fit bucket	Unit	EC240B LC prime/EC240B NLC prime			EC240B LR prime
		6.0 m boom			10.2 m boom
		2.5 m arm	2.97 m arm	3.6 m arm	7.85 m arm
A. Max. digging reach	mm	9,880	10,260	10,730	18,307
B. Max. digging reach on ground	mm	9,690	10,080	10,560	18,207
C. Max. digging depth	mm	6,500	6,980	7,600	14,347
D. Max. digging depth (2.44 m level)	mm	6,280	6,740	7,380	14,233
E. Max. vertical wall digging depth	mm	5,730	5,970	6,270	12,783
F. Max. cutting height	mm	9,620	9,690	9,660	14,891
G. Max. dumping height	mm	6,700	6,800	6,820	12,579
H. Min. front swing radius	mm	3,910	3,890	3,890	5,210















Digging forces with direct fit bucket		Unit	EC240B LC prime/EC240B NLC prime			EC240B LR prime
			6.0 m boom			10.2 m boom
			2.5 m arm	2.97 m arm	3.6 m arm	7.85 m arm
Bucket radius		mm	1,537	1,537	1,537	1,250
Breakout force – bucket (Normal/Power boost)	SAE J1179	kN	148/157	148/157	148/157	69
	ISO 6015	kN	166/176	166/176	166/176	78
Tearout force – arm (Normal/Power boost)	SAE J1179	kN	129/137	112/119	100/106	44
	ISO 6015	kN	133/141	115/122	102/108	45
Rotation angle, bucket		deg	177	177	177	179

Lifting capacity

At the arm end without bucket.

For lifting capacity including bucket, simply subtract actual weight of the direct fit bucket or the bucket with quick fit from the following values.

• EC240B LC prime

 Across undercarriage  Along undercarriage	Lifting hook related to ground level	1.5 m		3.0 m		4.5 m		6.0 m		7.5 m		Max. reach						
															Max. mm			
Boom 6.0 m + Arm 2.5 m + Shoe 600 mm + Counterweight 4,600 kg	7.5 m kg								*5570	*5570			*5620	5300	6,119			
	6.0 m kg								*5,650	5,550			*5,650	3,820	7,236			
	4.5 m kg								*6,490	5,350	5,650	3,520	5,080	3,140	7,914			
	3.0 m kg							*8,000	*8,000	8,060	*7,650	5,060	5,530	3,420	4,620	2,810	8,265	
	1.5 m kg							*12,510	7,490	7,870	4,790	5,390	3,290	4,480	2,700	8,330		
	0 m kg							12,670	7,280	7,680	4,620	5,300	3,200	4,640	2,790	8,116		
	-1.5 m kg				*9,050	*9,050	12,670	7,280	7,620	4,570	5,280	3,190	5,170	3,120	7,600			
	-3.0 m kg				*16,920	15,580	*12,080	7,420	7,710	4,650			6,430	3,910	6,709			
-4.5 m kg				*13,480	*13,480	*9,620	7,750					*7,870	6,050	5,253				
Boom 6.0 m + Arm 2.97 m + Shoe 600 mm + Counterweight 4,600 kg	7.5 m kg												*4,900	4,650	6,630			
	6.0 m kg								*5,090	*5,090	*5,110	3,640	*4,710	3,460	7,672			
	4.5 m kg								*7,140	*7,140	*5,960	5,450	*5,410	3,580	4,680	2,870	8,314	
	3.0 m kg								*9,690	8,270	*7,170	5,140	5,580	3,450	4,270	2,580	8,648	
	1.5 m kg								*11,890	7,610	7,930	4,830	5,410	3,300	4,140	2,470	8,710	
	0 m kg								12,710	7,280	7,680	4,610	5,290	3,180	4,260	2,530	8,506	
	-1.5 m kg			*5,580	*5,580	*9,240	*9,240	12,610	7,210	7,580	4,520	5,230	3,130	4,690	2,800	8,015		
	-3.0 m kg			*10,870	*10,870	*15,890	15,310	*12,440	7,290	7,610	4,550			5,680	3,420	7,178		
-4.5 m kg					*15,030	*15,030	*10,560	7,550					*7,640	4,960	5,843			
Boom 6.0 m + Arm 3.6 m + Shoe 600 mm + Counterweight 4,600 kg	7.5 m kg													*3,920	*3,920	7,241		
	6.0 m kg											*4,450	3,740	*3,820	3,070	8,204		
	4.5 m kg									*5,240	*5,240	*4,870	3,650	*3,900	2,590	8,806		
	3.0 m kg									*6,510	5,230	*5,540	3,500	3,890	2,330	9,122		
	1.5 m kg									*7,830	4,900	5,440	3,330	3,770	2,230	9,181		
	0 m kg									12,600	7,370	7,710	4,640	5,290	3,190	3,860	2,270	8,988
	-1.5 m kg			*5,640	*5,640	*9,300	*9,300	12,590	7,200	7,560	4,510	5,200	3,110	4,190	2,480	8,525		
	-3.0 m kg			*9,590	*9,590	*14,180	*14,180	12,610	7,220	7,540	4,490	5,200	3,110	4,940	2,950	7,744		
-4.5 m kg			*14,560	*14,560	*16,930	15,540	*11,590	7,390	7,670	4,610			6,670	4,030	6,529			
-6.0 m kg							*8,280	7,810					*8,210	7,720	4,531			
Boom 6.0 m HD + Arm 2.5 m + Shoe 600 mm + Counterweight 4,600 kg	7.5 m kg									*5,540	5,520			*5,620	5300	6,119		
	6.0 m kg									*5,630	5,540			*5,650	3,820	7,236		
	4.5 m kg									*7,970	*7,970	*6,460	5,340	5,640	3,510	5,080	3,140	7,914
	3.0 m kg									*10,500	8,030	*7,610	5,040	5,520	3,400	4,620	2,810	8,265
	1.5 m kg									*12,440	7,440	7,840	4,760	5,370	3,270	4,480	2,700	8,330
	0 m kg									12,620	7,220	7,640	4,590	5,270	3,180	4,640	2,790	8,116
	-1.5 m kg					*9,050	*9,050	12,620	7,220	7,590	4,530	5,260	3,160	5,170	3,120	7,600		
	-3.0 m kg					*16,820	15,480	*12,000	7,370	7,680	4,610			6,430	3,910	6,709		
-4.5 m kg					*13,380	*13,380	*9,560	7,700					*7,870	6,050	5,253			
Boom 6.0 m HD + Arm 2.97 m + Shoe 600 mm + Counterweight 4,600 kg	7.5 m kg													*4,900	4,650	6,630		
	6.0 m kg									*5,040	*5,040	*5,070	3,600	*4,710	3,460	7,672		
	4.5 m kg									*7,090	*7,090	*5,910	5,410	*5,370	3,540	4,680	2,870	8,314
	3.0 m kg									*9,630	8,200	*7,120	5,090	5,530	3,410	4,270	2,580	8,648
	1.5 m kg									*11,820	7,540	7,870	4,770	5,370	3,250	4,140	2,470	8,710
	0 m kg									12,620	7,210	7,620	4,560	5,240	3,140	4,260	2,530	8,506
	-1.5 m kg			*5,560	*5,560	*9,220	*9,220	12,530	7,140	7,520	4,470	5,190	3,090	4,690	2,800	8,015		
	-3.0 m kg			*10,860	*10,860	*15,870	15,210	*12,390	7,230	7,560	4,500			5,680	3,420	7,178		
-4.5 m kg					*14,970	*14,970	*10,520	7,500					*7,640	4,960	5,843			
Boom 6.0 m HD + Arm 3.6 m + Shoe 600 mm + Counterweight 4,600 kg	7.5 m kg													*3,920	*3,920	7,241		
	6.0 m kg											*4,430	3,730	*3,820	3,070	8,204		
	4.5 m kg									*5,220	*5,220	*4,850	3,640	*3,900	2,590	8,806		
	3.0 m kg									*6,480	5,220	*5,510	3,480	3,890	2,330	9,122		
	1.5 m kg									*10,970	7,770	*7,790	4,880	5,430	3,310	3,770	2,230	9,181
	0 m kg									12,530	7,320	7,680	4,610	5,270	3,160	3,860	2,270	8,988
	-1.5 m kg			*5,640	*5,640	*9,300	*9,300	12,540	7,140	7,520	4,470	5,170	3,080	4,190	2,480	8,525		
	-3.0 m kg			*9,590	*9,590	*14,180	*14,180	12,560	7,160	7,500	4,450	5,180	3,080	4,940	2,950	7,744		
-4.5 m kg			*14,560	*14,560	*16,820	15,440	*11,520	7,340	7,640	4,570			6,670	4,030	6,529			
-6.0 m kg							*8,220	7,760					*8,210	7,720	4,531			

Notes: 1. Machine in "Fine Mode-F" (Power Boost), for lifting capacities.

2. The above loads are in compliance with SAE J1097 and ISO 10567 Hydraulic Excavator Lifting Capacity Standards.

3. Rated loads do not exceed 87% of hydraulic lifting capacity or 75% of tipping load.

















4. Rated loads marked with an asterisk (*) are limited by hydraulic capacity rather than tipping load.

Lifting capacity

At the arm end without bucket.

For lifting capacity including bucket, simply subtract actual weight of the direct fit bucket or the bucket with quick fit from the following values.

• EC240B LR prime

 Across undercarriage  Along undercarriage	Lifting hook related to ground level	6.0 m		7.5 m		9.0 m		10.5 m		12.0 m		13.5 m		Max. reach			
																Max. mm	
Boom 10.2 m + Arm 7.85 m + Shoe 800 mm + Counterweight 6,600 kg	12.0 m	kg											*1,020	*1,020	*870	*870	13,704
	10.5 m	kg											*1,550	*1,550	*840	*840	14,703
	9.0 m	kg											*1,870	*1,870	*820	*820	15,492
	7.5 m	kg									*2,140	*2,140	*2,110	*2,110	*820	*820	16,101
	6.0 m	kg									*2,300	*2,300	*2,220	2,030	*830	*830	16,551
	4.5 m	kg							*2,700	*2,700	*2,500	2,430	*2,360	1,930	*860	*860	16,855
	3.0 m	kg	*5,020	*5,020	*4,020	*4,020	*3,410	*3,410	*3,010	2,860	*2,730	2,270	*2,520	1,810	*890	*890	17,021
	1.5 m	kg	*6,120	5,860	*4,710	4,330	*3,870	3,330	*3,330	2,630	*2,960	2,100	*2,690	1,700	*940	*940	17,052
	0 m	kg	*7,010	5,180	*5,310	3,890	*4,290	3,030	*3,640	2,410	3,160	1,950	2,620	1,590	*1,010	1,000	16,949
	-1.5 m	kg	*6,290	4,750	*5,770	3,560	4,570	2,790	3,670	2,240	3,020	1,820	2,520	1,500	*1,100	1,000	16,711
	-3.0 m	kg	*5,990	4,510	5,660	3,340	4,380	2,610	3,530	2,100	3,910	1,720	2,450	1,420	*1,220	1,020	16,330
	-4.5 m	kg	*6,270	4,410	5,530	3,230	4,270	2,510	3,440	2,020	2,840	1,650	2,400	1,380	*1,380	1,070	15,797
	-6.0 m	kg	*6,890	4,400	5,490	3,190	4,220	2,460	3,390	1,970	2,810	1,620	2,830	1,360	*1,610	1,150	15,095
	-7.5 m	kg	*7,720	4,470	5,520	3,210	4,230	2,470	3,390	1,980	2,820	1,630	2,400	1,380	*1,950	1,290	14,199
	-9.0 m	kg	*7,270	4,610	5,610	3,300	4,290	2,530	3,450	2,030	2,880	1,680			*2,500	1,510	13,069
	-10.5 m	kg	*6,560	4,810	*5,300	3,450	*4,370	2,650	3,570	2,140					*3,100	1,870	11,635
	-12.0 m	kg	*5,480	5,110	*4,450	3,680	*3,600	2,850							*3,200	2,560	9,763

Notes: 1. Machine in "Fine Mode-F" (Power Boost), for lifting capacities.

2. The above loads are in compliance with SAE J1097 and ISO 10567 Hydraulic Excavator Lifting Capacity Standards.

3. Rated loads do not exceed 87% of hydraulic lifting capacity or 75% of tipping load.

4. Rated loads marked with an asterisk (*) are limited by hydraulic capacity rather than tipping load.

STANDARD EQUIPMENT

Engine

Turbocharged, 4 stroke 6 cylinder diesel engine water cooling, common rail direct injection and charged air cooler
2 stage air filter with indicator
Air intake heater
Electric engine shut-off
Fuel filler and water separator with indicator
Alternator, 28V/80 A

Electric / Electronic control system

Contronics:
– Advanced mode control system
– Self-diagnostic system
Machine status indication
Engine speed sensing power control
"Power Max" mode system
Automatic idling system
One-touch power boost
Safety stop/start function
Adjustable monitor
Engine restart prevention circuit
High capacity halogen lights:
– Frame mounted 2
– Boom mounted 1
Batteries, 2 x 12 V/200 Ah
Start motor, 24 V/5.5 kW

Hydraulic system

Automatic hydraulic system:
– Summation system
– Boom priority
– Arm priority
– Swing priority
Boom and arm regeneration valves
Swing anti-rebound valves
Boom and arm holding valves
Multi-stage filtering system
Cylinder cushioning
Cylinder contamination seals
Auxiliary hydraulic valve
Automatic two-speed travel motors

Superstructure

Access way with handrail
Tool storage area
Punched metal anti-slip plates

Cab and interior

Hydraulic dampening cab mounts
Adjustable operator seat and joystick control console
Control joystick with 3 switches each
Flexible antenna
Hydraulic control lockout lever

Cab, all-weather sound suppressed, includes:
– Ashtray
– Cup holder
– Lighter
– Tinted glass
– Door locks
– Floor mat
– Horn
– Large storage area
– Pull-up type front window
– Removable lower windshield
– Seat belt
– Tinted safety glass
Front (upper & lower): laminated glass
Side & rear: tempered glass
– Windshield wiper with intermittent function
Master key

Undercarriage

Greased and sealed track link
Track guards

OPTIONAL EQUIPMENT

Engine

Diesel coolant heater, 5 kW
Oil bath pre-cleaner
Dry pre-cleaner
Fuel filler pump: 35 l/min
Water separator with heater

Electric

Extra lights:
– Cab-mounted 3, (front 2, rear 1)
– Boom-mounted 1
– Counterweight-mounted 1
Rotating warning beacon
Travel alarm
Anti-theft system

Hydraulic system

Hammer & shear piping
– 1 and 2 pump flow
– Pump flow control for hammer & shears
– Additional return filter
– 1 switch control
– 2 switch control
– Pedal control
Slope & rotator piping
Oil leak (drain) line piping
Quick fit piping
Volvo hydraulic quick fit (S1, S2, U)
Hydraulic oil, ISO VG 32
Hydraulic oil, ISO VG 46

Hydraulic oil, ISO VG 68
Boom floating function

Superstructure

Counterweight,
LC prime: 4,600/5,300 kg
NLC prime: 5,300 kg
LR prime: 6,600 kg
Undercover: 2.3 mm/4.5 mm HD

Cab and interior

Fabric seat
Fabric seat with heater and air suspension
Air-conditioner without heater, manual
Heater & air-conditioner, automatic
Semi-long joysticks
Control joystick with 5 switches each
Cab-mounted falling object guard (FOG)
Cab-mounted falling object protective structures (FOPS)
AM/FM stereo radio
AM/FM stereo with CD player and MP3 input
Rain shield, front
Sun screens, front, roof, rear
Sunlight protection, roof (steel)
Safety screen for front window
Lower wiper
Anti-vandalism kit assembly preparation
Anti-vandalism kit
Specific key

Undercarriage

Full track guards
Undercover: 4.5 mm/10 mm HD

Track shoes

Track shoes 600/700/800/900 mm with triple grousers
Track shoes 700 mm with double grousers

Digging equipment

Boom: 6.0 m GP
6.0 m HD
10.2 m LR
Arm: 2.5/2.97/3.6 m GP
2.97 m HD
7.85 m LR

Service

Hand lamp
Spare parts
Tool kit, full scale
Tool kit, daily maintenance
CareTrack



Volvo Construction Equipment is different. Our machines are designed, built and supported in a different way. That difference comes from an engineering heritage of over 175 years. A heritage of thinking first about the people who actually use the machines. About how to help them be safer, more comfortable, more productive. About the environment we all share. The result of that thinking is a growing range of machines and a global support network dedicated to helping you do more. People around the world are proud to use Volvo. And we're proud of what makes Volvo different – **More care. Built in.**



Not all products are available in all markets. Under our policy of continuous improvement, we reserve the right to change specifications and design without prior notice. The illustrations do not necessarily show the standard version of the machine.

VOLVO

Volvo Construction Equipment
www.volvoce.com

PUB 20021128-A
2010.01
Volvo, Global Marketing

English (International)
EXC